

Minuteman[®] ***Parker***[®]

Model:
PV9908KLP
PV9908KSPL
PV9908KSPLR

Vac-35 Propane

OPERATION

SERVICE

PARTS

CARE

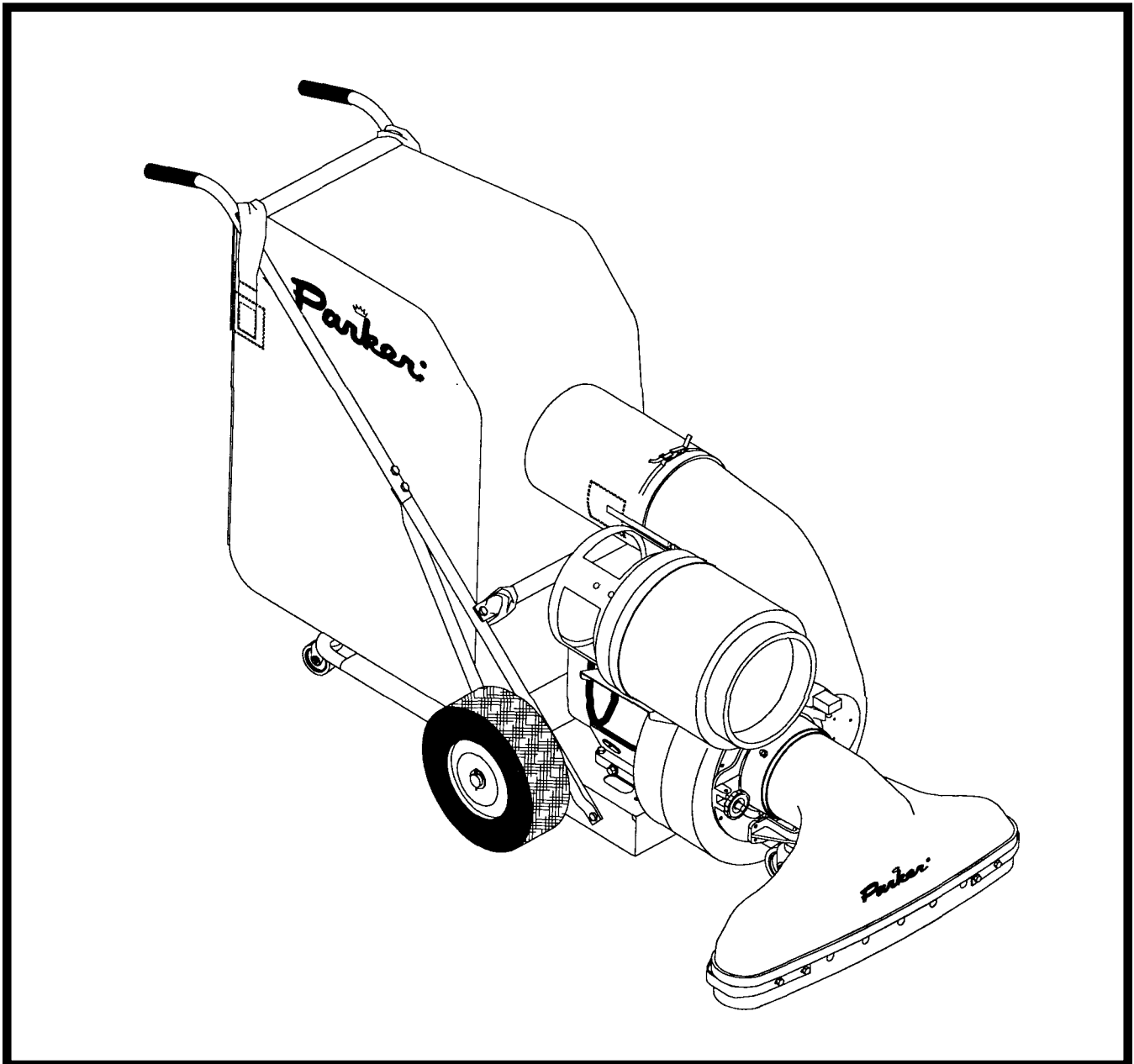

Revised 7/05



DECLARATION OF CONFORMITY

MANUFACTURER'S NAME: Minuteman International Inc.

MANUFACTURER'S ADDRESS: 111 South Rohlwing Road
Addison, IL. 60101

EQUIPMENT DESCRIPTION: VAC 35 SELF PROPELLED

EQUIPMENT MODEL DESIGNATION: PV9908KSPL

Application of Council Directives: 89/392/EC, 2000/14/EC, 91/368/EC, 98/37/EC

Harmonized EN standards complied with: EN 292

Additional Standards: ISO 3744, ISO 11094

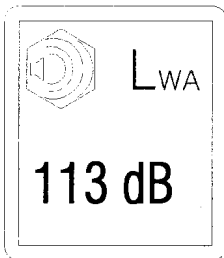

I, the undersigned, hereby declare that the equipment specified above conforms to the above Directive(s) and Standard(s).

SIGNATURE:

Jeffrey Pollack

DATE: April 26, 2004

PRINTED NAME:

Jeffrey Pollack

TITLE:

Standards Engineer

TABLE OF CONTENTS

1 & 2	General Safety Instructions
3	Warning Decal Replacement
4	Assembly Operating Instructions
5	Handle Assembly Instructions
6	Transport Drive/Parking Brake
7	Safety Interloc System
8	Accessories
9, 10, 11	Repair Parts, Engine
12, 13	Repair Parts, Handle Assembly
14, 15	Repair Parts, Traction System
16, 17	Repair Parts, Blower Assembly

Model # _____ Serial # _____

IMPORTANT SAFETY INSTRUCTIONS

READ ALL INSTRUCTIONS BEFORE USING

WARNING

- To prevent personal injury or property damage, do not attempt to start engine until all assembly steps are complete and you have read and understand the safety and operating instructions in this manual.
- Under California law, and under laws of several other states, you are not permitted to operation internal combustion's engine using hydrocarbon fuels on any forest covered, brush covered, or grass covered land, or on land with grain, hay, or other flammable agricultural crop, without an engine spark arrester in continuous effective working order. The engine on your power equipment, like most outdoor power equipment, is an internal combustion engine that burns gasoline, a hydrocarbon fuel. Therefore, your power equipment must be quipped with a spark arrester muffler in continuous effective working order. The spark arrester must be attached to the engine exhaust system in such a manner that flames or heat from the system will not ignite flammable material. Failure of the owner/operator of the equipment to comply with this regulation is a misdemeanor under California law, and may also be a violation of other state and/or federal regulations, laws, ordinances, or codes. Contact your local fire marshal or forest service for specific information about what regulations apply in your area.
- Wear approved safety glasses when operating this equipment. The operation of any powered machine can result in foreign objects being thrown by high-speed rotating parts.
- Wear work gloves, sturdy footwear, and hearing protection when operating this equipment.
- Remove hearing protection and watch for traffic when operating near, or when crossing roadways.
- Before inspecting or servicing any part of equipment, shut off engine, disconnect spark plug wire from spark plug, and make sure that all moving parts have come to a complete stop. Be aware that rotating blades slow down gradually after engine is shut off.
- Exercise extreme caution on slopes and avoid excessively steep slopes.
- Never leave equipment unattended when engine is running. Shut off engine and disconnect spark plug wire from spark plug before leaving equipment. Turn off fuel shut-off if equipped.
- Do not vacuum any burning or smoldering materials such as cigars, cigarettes, ashes, or cinders.
- Do not vacuum areas that have been recently treated with fertilizers, pesticides, or herbicides. Follow chemical manufacturer's safety instructions regarding contact with treated areas.
- Do not vacuum flammable liquids such as gasoline, kerosene, diesel fuel, paint thinner, etc.
- Do not operate the equipment on a paved, gravel, or hard surface unless the collection bag is installed. Discharged material may bounce from a hard surface.
- Never pick up or carry equipment while the engine is running.
- Walk, never run.
- Never allow children or untrained adults to operate this equipment.
- Keep the area of operation clear of all persons, particularly small children, and pets. Keep bystanders at least 25 feet away from the area of operation.

- Do not run engine in an enclosed area. Engine exhaust contains carbon monoxide gas, a deadly poison that is odorless, colorless, and tasteless.
- Before removing or installing collection bag, shut off engine, disconnect spark plug wire from spark plug, and allow all moving parts to come to a complete stop.
- Do not allow hands or any other part of the body or clothing inside the vacuum inlet.
- Do not start engine or operate this equipment with any safety guards or housing removed.
- If equipment jams or becomes clogged, immediately shut off engine, disconnect spark plug wire from spark plug, and allow all moving parts to come to a complete stop. Use only a wooden stick to clear away debris.
- Empty the collection bag after each use. Decomposed debris could generate enough heat to catch fire. Before emptying the collection bag, shut off engine, disconnect spark plug wire from spark plug, and allow all moving parts to come to a complete stop.

DANGER

Liquid propane is highly flammable and its vapors are explosive. To prevent personal injury or property damage:

- Do not allow open flame, matches, or smoking in area.
- Never overfill a propane tank. The tank supplied with this machine is a horizontal vapor withdrawal 20 lb. tank. Weight fill tank only 80% of rated capacity. Tare weight is stamped on the tank.
- Always store propane tank outside in an approved, secured, tamper proof enclosure to provide safety from vandalism and accidents.
- Never use a non-UL listed propane tank.
- Never change or alter the fuel system unless authorized by Minuteman International Inc. Service Department.

SAVE THESE INSTRUCTIONS

SAFETY DECALS

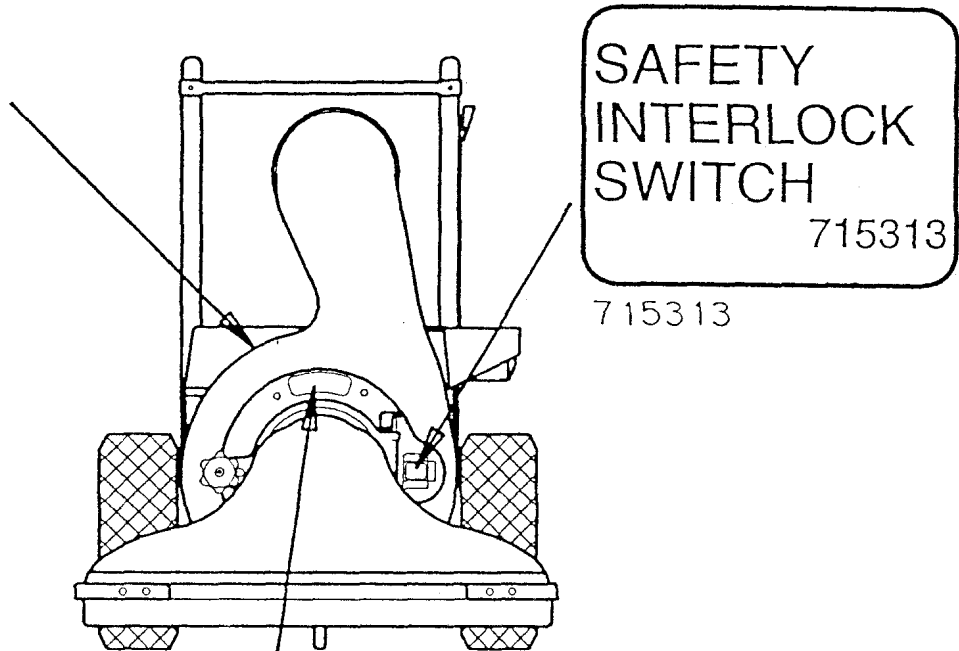
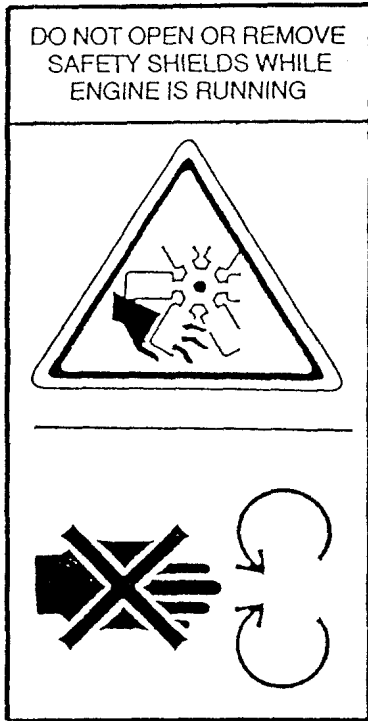

STOP FAN BEFORE
REMOVING HOUSING
FAN ← ROTATION

85-151-A

OPERATING INSTRUCTIONS

READ SAFETY OPERATING INSTRUCTIONS BEFORE OPERATING EQUIPMENT

1. Heavy concentration of sand and gravel should be avoided. These materials are extremely abrasive, and while the VAC 35 will handle moderate amounts of these materials, it is not designed for heavy applications. Treat your VAC 35 with reasonable care and it will repay you with long, trouble-free service.
2. The VAC 35 will handle most common kinds of debris found around industrial plants, commercial buildings, homes and farms. Acid contaminated materials, magnesium, dust and other DANGEROUS DEBRIS that is considered hazardous should not be handled with the VAC 35.
3. The efficiency of this unit depends on the breathing capacity of the dust bag. Under extremely dusty conditions the bag should be emptied and cleaned frequently. Always empty and clean bag before storing after use. Debris allowed to remain in the bag may cause spontaneous combustion, resulting in an explosion or fire. See instructions supplied with dust bag.

DUST BAG CARE

1. To clean dust bag, turn the bag inside out and reattach to unit.
2. Start engine and run at full throttle. Lightly tap bag to release dirt trapped in the weave.
3. When clean, turn bag right side out and reattach to unit.
4. Bag can be washed if extremely dirty.

BEFORE STARTING ENGINE

IMPORTANT: Read the Engine Manual CAREFULLY before operating the VAC 35. Before starting the engine read and understand the following:

1. Be sure the engine crankcase is filled with the proper type and amount of oil.
2. Spin-Pak® is in place.
3. Dust bag or discharge hose is in place.
4. Intake housing or hose kit is attached to the fan housing.

TO START ENGINE

IMPORTANT: Read the dangers of liquid propane fuel before operating the VAC-35.

1. Move the throttle lever to the full throttle position.
2. Move the choke lever to the choke on position.
3. Open the valve on the propane tank by turning the knob counterclockwise.
4. This engine does not require a primer to start. A couple of quick pulls on the starter cord will disengage the safety lock-off and allow propane to flow to the engine.
5. Upon engine startup move the choke lever to the choke off position then adjust throttle lever.

TO STOP ENGINE

1. Move the throttle lever to the slow position.
2. Close the valve on the propane tank by rotating the handle clockwise
3. Allow the engine to run until all of the propane in the fuel line has been used up. When the engine stops the safety lock-off will automatically engage.
4. Remove any hearing protection and listen for all moving parts to come to a complete stop.

LUBRICATION

Add a few drops of oil to the throttle control cable and wire to help keep it operating smoothly.

Clearing the Machine of Clogs and Jams

A clog or jam in the machine can cause the vacuuming operation to decrease or even stop completely. If this occurs, take the following steps:

1. STOP THE ENGINE IMMEDIATELY and disconnect the spark plug wire from the spark plug. Wait for all moving parts to come to a complete stop.
2. Check (and clean, if necessary) the following areas in this order:
 - Check that the collection bag is not overfilled. Remove and empty bag.
 - While the bag is removed, check that the discharge deflector is not clogged or jammed. Use a stick to clear away any debris.
 - Check that the vacuuming attachment is not clogged or jammed. Remove the attachment and thoroughly clean the opening. While the attachment is removed, check the inlet opening to the machine. Use a stick to clear away any debris.

ASSEMBLY INSTRUCTIONS

1. The VAC 35 covered in this owner's guide is shipped complete in one box. Follow all instructions on assembly very carefully.
2. Unpack all items from carton.
3. Tip box over so wheels are toward floor. Pull unit out of box and stand upright.
4. DO NOT discard the carton or any of the inserts until the unit is completely assembled.
5. All hardware is on the unit in its proper location. If something is missing, notify the dealer/distributor where unit was purchased.
6. Whenever the terms left or right hand, or "L" and "R" are used, it means from a position standing behind the unit facing forward.

NOTE: Before continuing with instructions in this Owner's Manual, unpack items from small carton. Assemble those items as outlined in Instruction Sheet included in that package.

HANDLE ASSEMBLY

NOTE: See Handle Assembly on Page 11 of this owner's guide for reference to numbers used in the following instructions.

1. Remove hex head bolts (14) and hexagon lock nuts (7) from the bottoms of the upper handles (21) and (25).
2. Place upper handles (21) and (25) over the ends of the lower handles (27).
3. Align the lower holes in both upper and lower handles. Replace hexagon head bolts (14), removed in Step 1, to each of the lower holes.
4. Lift handles until the back braces (28) can be assembled to bolts (14) assembled in Step 3. Assemble hexagon lock nuts (7). DO NOT TIGHTEN.
5. Align the upper holes in both upper and lower handles. Assemble the remaining two hexagon head bolts (14) and hexagon lock nuts (7). DO NOT TIGHTEN.

NOTE: Check alignment of handle. The hexagon lock nuts have been left loose to allow movement between the holes and the bolts. Do not bend tubing to accomplish proper alignment.

6. Once handles are aligned, tighten all hexagon lock nuts (7).

NOTE: Nuts should be tightened enough that at least two of the bolt threads extend through the nut. It may be necessary to collapse the tubing SLIGHTLY to accomplish this.

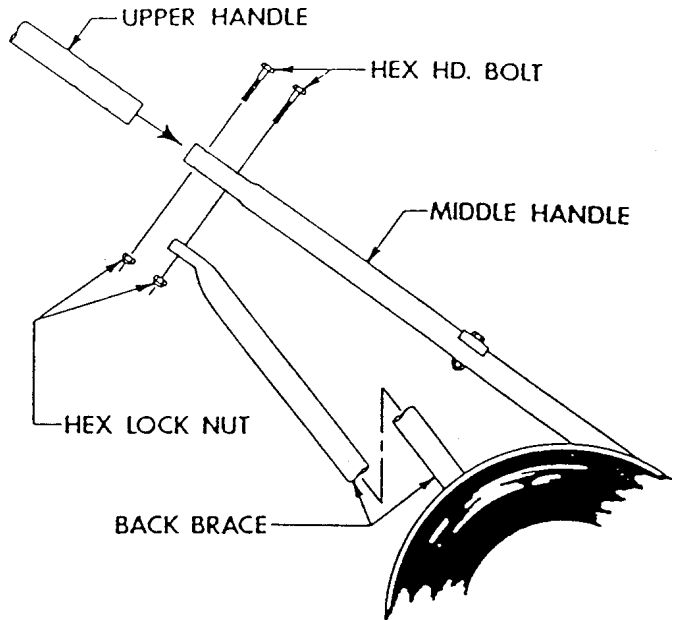

THROTTLE HOOKUP

1. Remove throttle control (26) from the right lower handle (27).
2. Straighten the throttle cable out and run it up the left hand handles (27) and (25).
3. Attach the throttle control (26) to the upper left hand handle (25) with the two oval head screws (3) and hexagon nuts (13) furnished.
4. Attach snap-on clamps (20) to handles to secure throttle cable.
5. Make sure no bends are less than 8" radius.

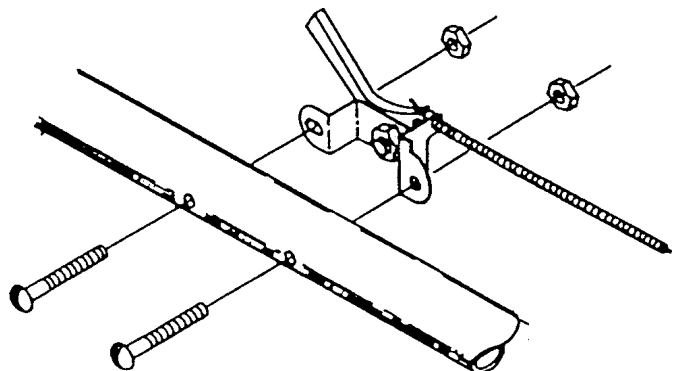

ASSEMBLY INSTRUCTIONS (Con't)

TO ASSEMBLE SPIN-PAK®

NOTE: See Housing Assembly on Page 16 of this owner's guide for reference to numbers used in the following instructions.

1. Remove hex head bolts (39), flat washers (30), and lock nuts (27) from the three upper holes used to secure retaining ring (58) to housing assembly (24). DO NOT remove the bottom bolt or retaining ring from housing assembly.
2. Align the holes in Spin-Pak® (59) with three upper holes in retaining ring and housing assembly.
3. Replace hardware removed in Step 1 and tighten.

ATTACHING INTAKE HOUSING

1. Insert hinge bosses on collar of intake housing (61) behind the hinged extension on front cover assembly (16).
2. Swing intake housing (61) to lay flat against front cover assembly (16).
3. Secure by placing flatwasher (31) and adjusting knob (53), on pivot bolt, over the collar of intake housing and tighten adjusting knob.

ATTACHING DUST BAG

1. Place large loop in upper bag straps over the upper handles.
2. Place neck of dust bag over Spin-Pak® until tie strap can be pulled tight around neck of housing, just over bead on retaining ring. Bead must be covered.
3. Place bag hooks onto loops in lower bag straps and hook to lower crossbar.

WARNING: Failure to attach bag hooks to lower crossbar can cause premature wear of bag and neck at the Spin-Pak®. The Spin-Pak® may also break prematurely due to excessive weight from the bag.

WARNING: The engine contains NO OIL. Read the Engine Instruction Manual carefully before operating the VAC 35. Be sure you know how to start and stop the engine before proceeding further. Do not start the engine until all assembly is finished.

WARNING: Make a thorough inspection to see that all fastenings are tight and all parts are properly installed. DO NOT start engine without intake housing and dust bag in place. If engine is started without intake housing attached, serious injury may result by drawing clothing or parts of the body into the fan. If engine is run without Spin-Pak® or dust bag, small stones or other objects may be picked up and propelled at operator or bystanders through the unprotected opening causing serious injury.

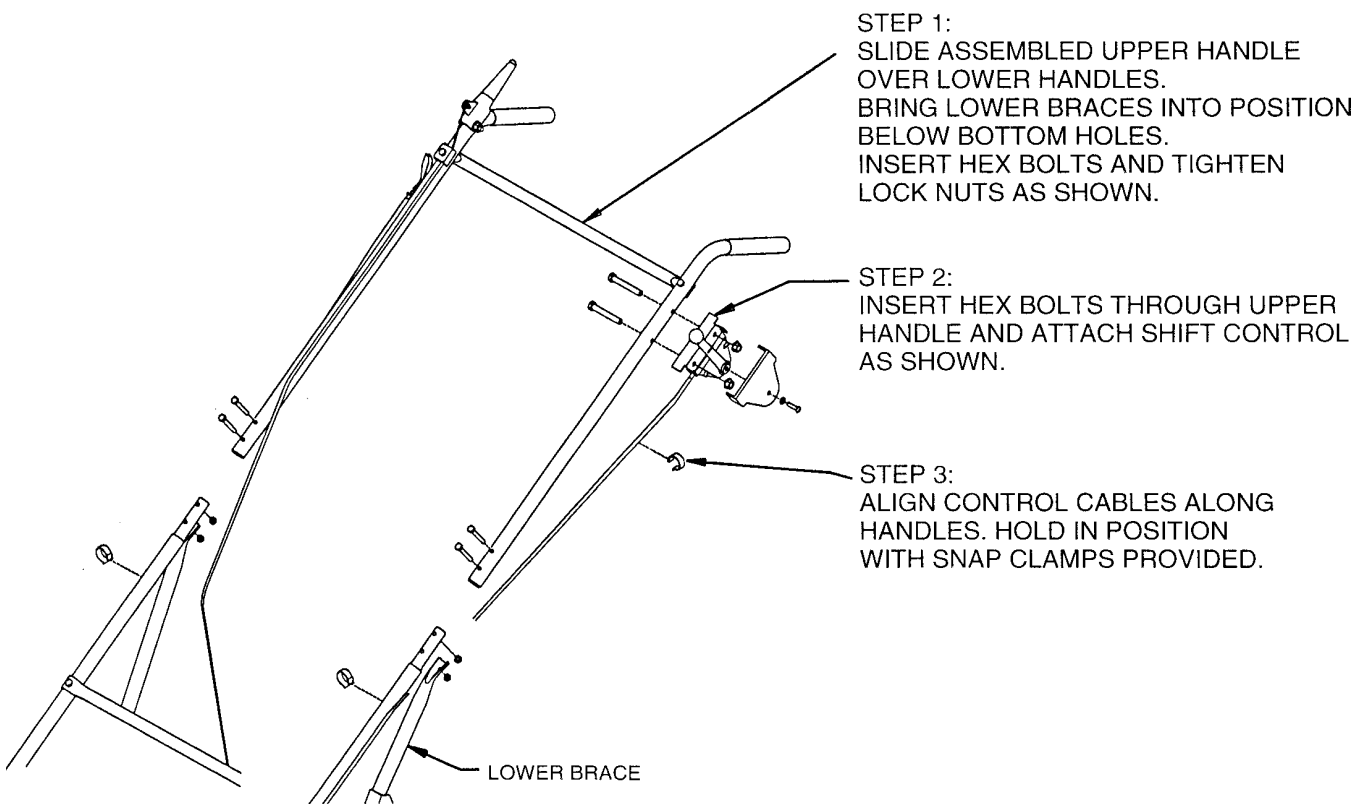

TRANSPORT DRIVE/PARKING BRAKE

Transport Drive

□ Operate the machine in a large, level, open area until you are familiar with its operation. Begin with speed No. 1 and gradually work up to speed No. 4. (Figure 1)

□ To avoid damaging the transmission, always release the Clutch Lever (Figure 2) and wait for the wheels to stop before shifting gears.

□ Forward momentum may cause the machine to gradually coast to a stop after the Wheel Drive is released (especially when in 3rd or 4th gear). Allow for this coasting distance when stopping the machine.

□ Engage the Clutch Lever slowly when starting off in 3rd or 4th gear. The machine may hesitate briefly before the wheels begin turning.

□ Shift to a lower forward gear if wheels lose traction when going up a slope (always avoid excessively steep slopes). Before shifting, turn the machine sideways on the slope to prevent rolling of the machine and to relieve strain on the transaxle.

□ Never force the shift lever as damage may result. If shifting is difficult, it may be necessary to manually move the machine a few inches forward or backward while moving the shift lever.

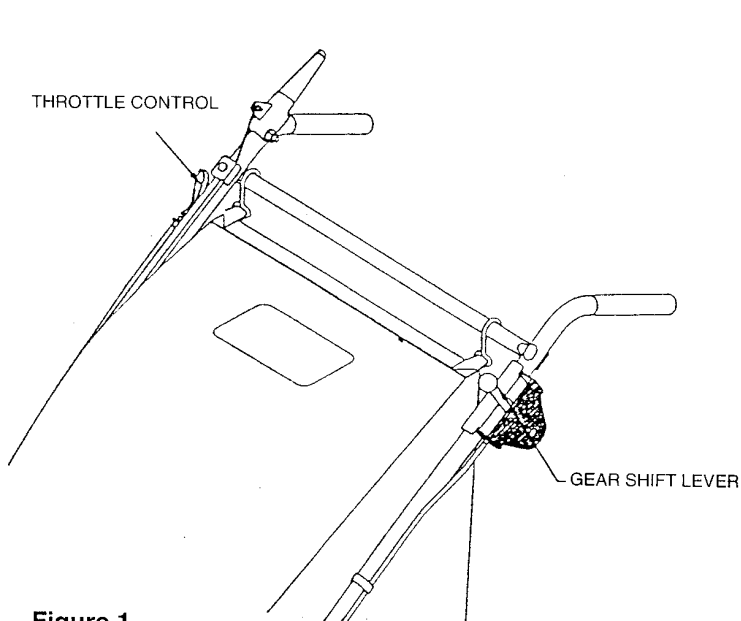

Figure 1

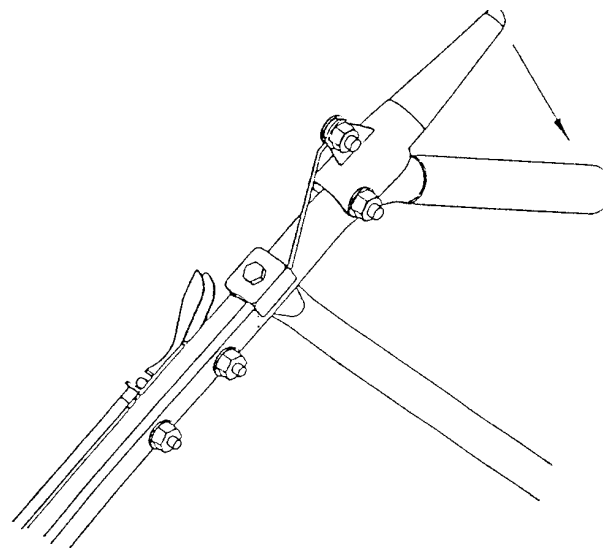
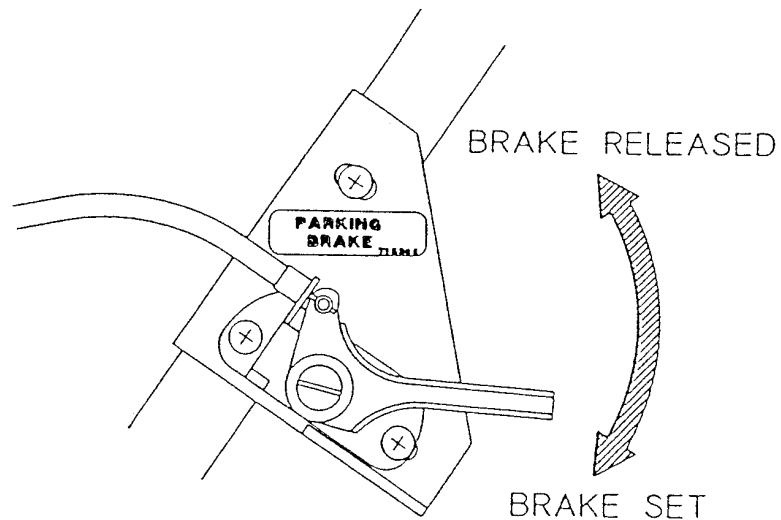

Figure 2

Parking Brake

Located on left side of machine.
Lower handle section - parking brake should be used on level surfaces.
The parking brake not intended to hold machine on slopes or inclines.



SAFETY INTERLOC SYSTEM

This equipment incorporates two safety interlock systems. Figure 1 below is for the front Vacuum Housing Assembly. Figure 2 is for the Cloth Bag Assembly. Both interlocks must be engaged for engine to start.

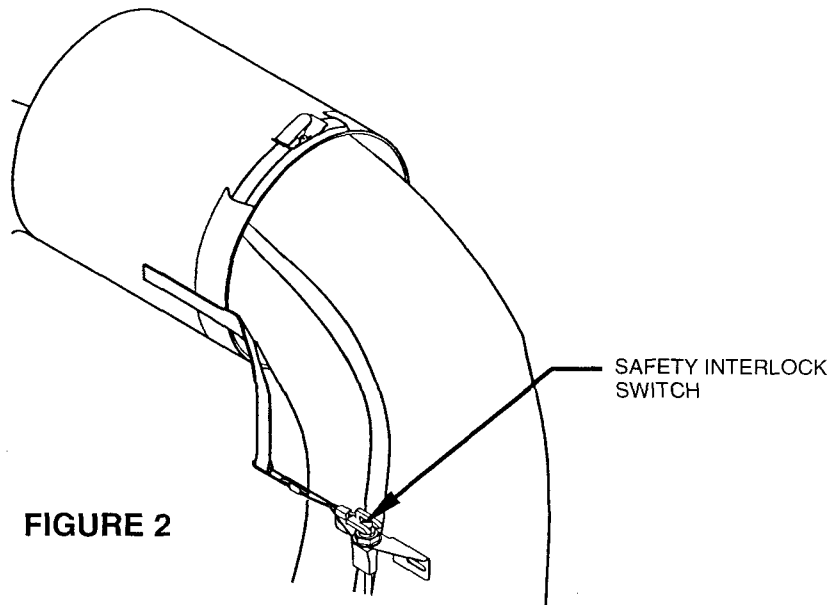
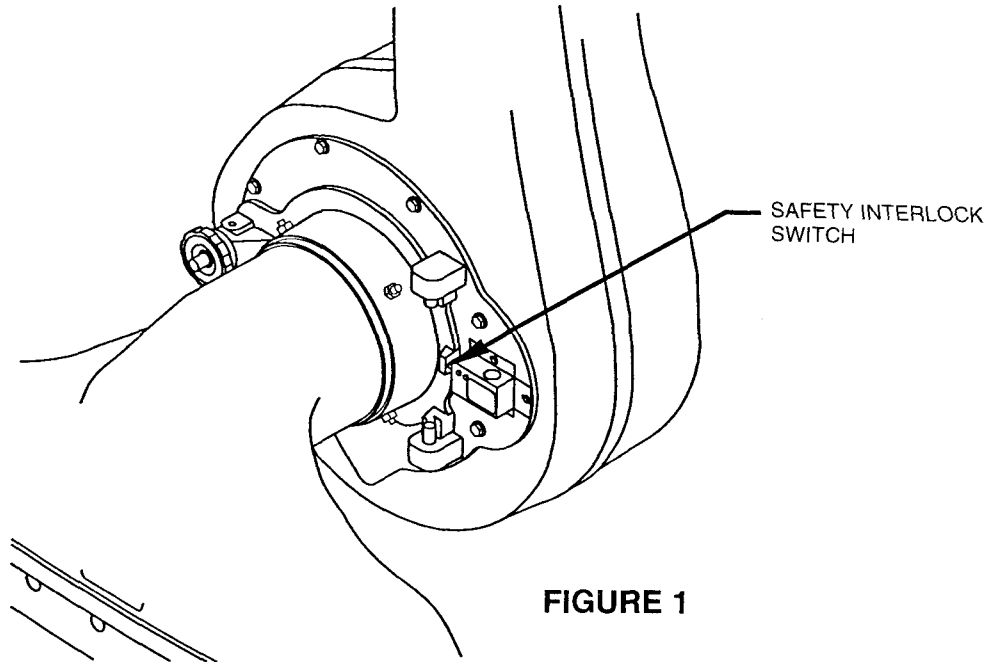

ACCESSORIES

MA-620-D 8 in. Hose Kit
MA-578-D 6 in. Hose Kit
MA-622-D 4 in. Hose Kit

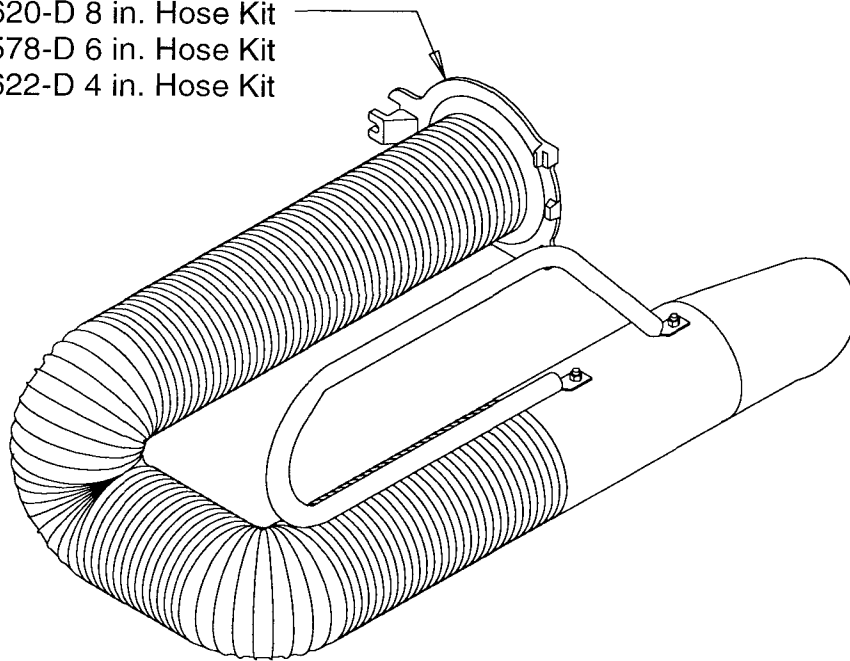

Optional MA-113-D 24 in. Intake
Standard MA-251-D 30 in. Intake
Optional MA-120-D 36 in. Intake

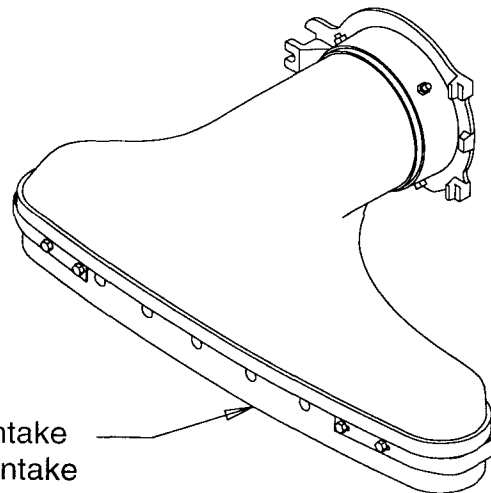

HANDLE ASSEMBLY - MANUAL MODEL

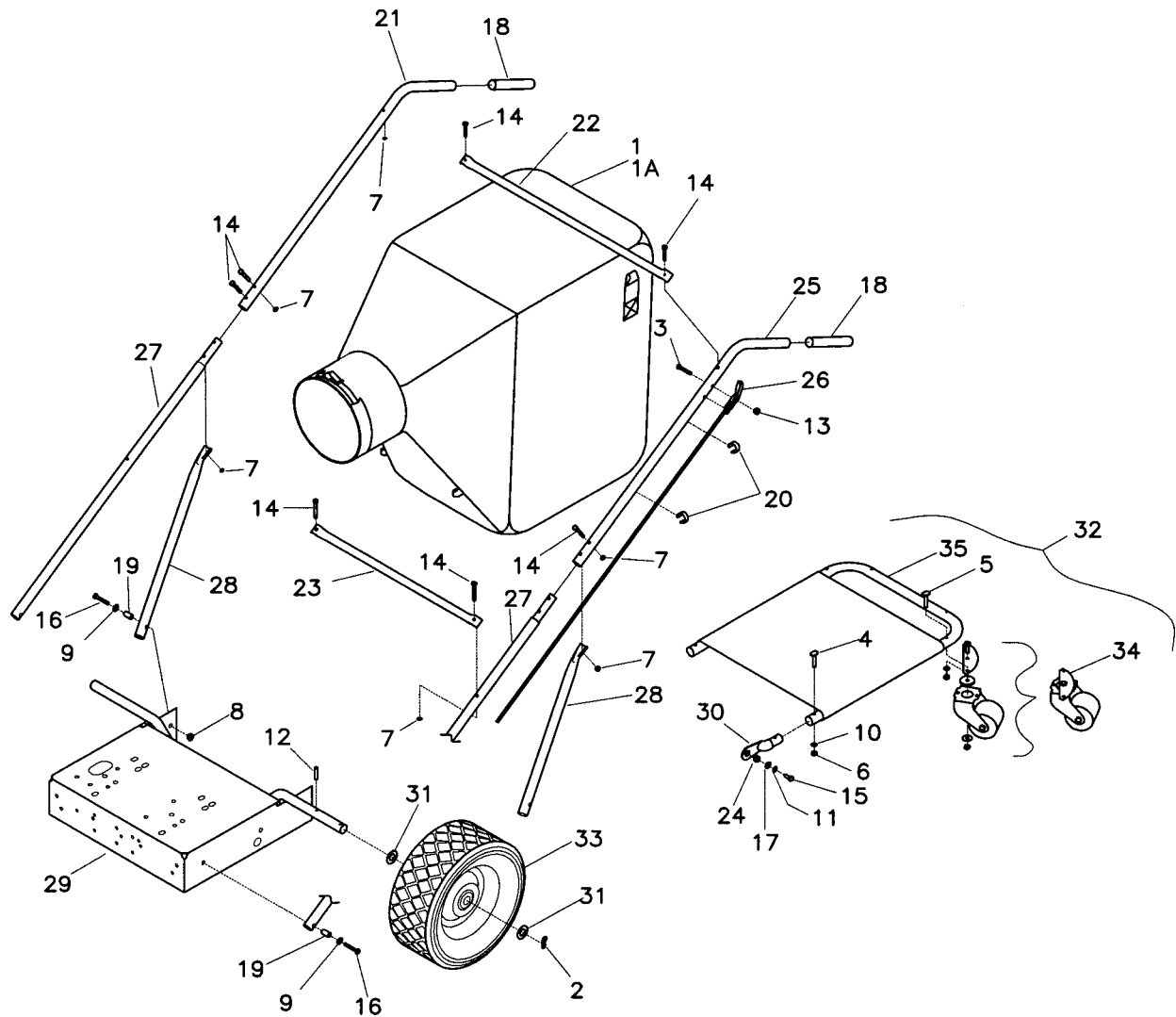

PARTS LIST

ITEM	PART NO.	REQ'D	DESCRIPTION	ITEM	PART NO.	REQ'D	DESCRIPTION
1	350800	1	BAG, CLOTH PV W/LANARD419	18	80-232-A	2	GRIP-HANDLE
1A	350850	1	BAG, VAC W/O PLATFORM 585	19	80-238-A	4	BUSHING-.437 OD X 1.00 L ZINC
2	380-432-20	2	PIN-COTTER	20	80-276-A	4	SNAP MOUNT
3	515-10-24	2	SCR-RD HD 10-24 X 1 1/2	21	80-321-C	1	HANDLE UPPER DRILLED &FO
4	69-416-24	8	BLT-CONT HEAD 1/4-20 X 1.50	22	81-04-B	1	CROSSBAR UPPER
5	69-416-28	2	BLT-CONT HEAD 1/4-20 X 1.75	23	81-58-B	1	CROSSBAR BRACE
6	711316	4	NUT-HEX 1/4-20 ST PL	24	81-120-A	2	SPACER .316X.626X.210
7	711373	6	NUT-NYLOC 1/4-20	25	83-18-C	1	HANDLE UPPER
8	711374	6	NUT-NYLOC 5/16-18	26	83-25-B-36	1	CABLE-THROTTLE ASSY
9	711506	2	WSR-FLT 5/16 (NARROW) ST PL	27	88-47-B	2	LOWER HANDLE
10	711544	2	WSR-HELICAL 1/4	28	88-48-C	2	HANDLE BACK BRACE
11	711545	8	WSR-HELICAL 5/16	29	88-60-C	1	CHASSIS WELDMENT
12	711644	2	PIN-ROLL 3/16 X 1 1/2	30	92-22	2	METAL END CAPS
13	712638	2	NUT HEX 10-24 SS NYLOC	31	945-1216	4	WSR-SPECIAL
14	713005	2	BLT-HH 1/4-20 X 1.50 #5	32	MA-471-D	1	BAG PLATFORM
15	713027	2	BLT-HH 5/16-18 X 1 #5	33	SA-231-B	2	WHEEL ASY
16	713031	4	BLT-HH 5/16-18 X 2 #5	34	SA-1021-B	1	CASTER & PLATE ASY
17	76-36-A	2	WSR-SPECIAL	35	SA-1023-C	1	FRAME AND PLATFORM ASY

HANDLE ASSEMBLY - SELF-PROPELLED MODEL

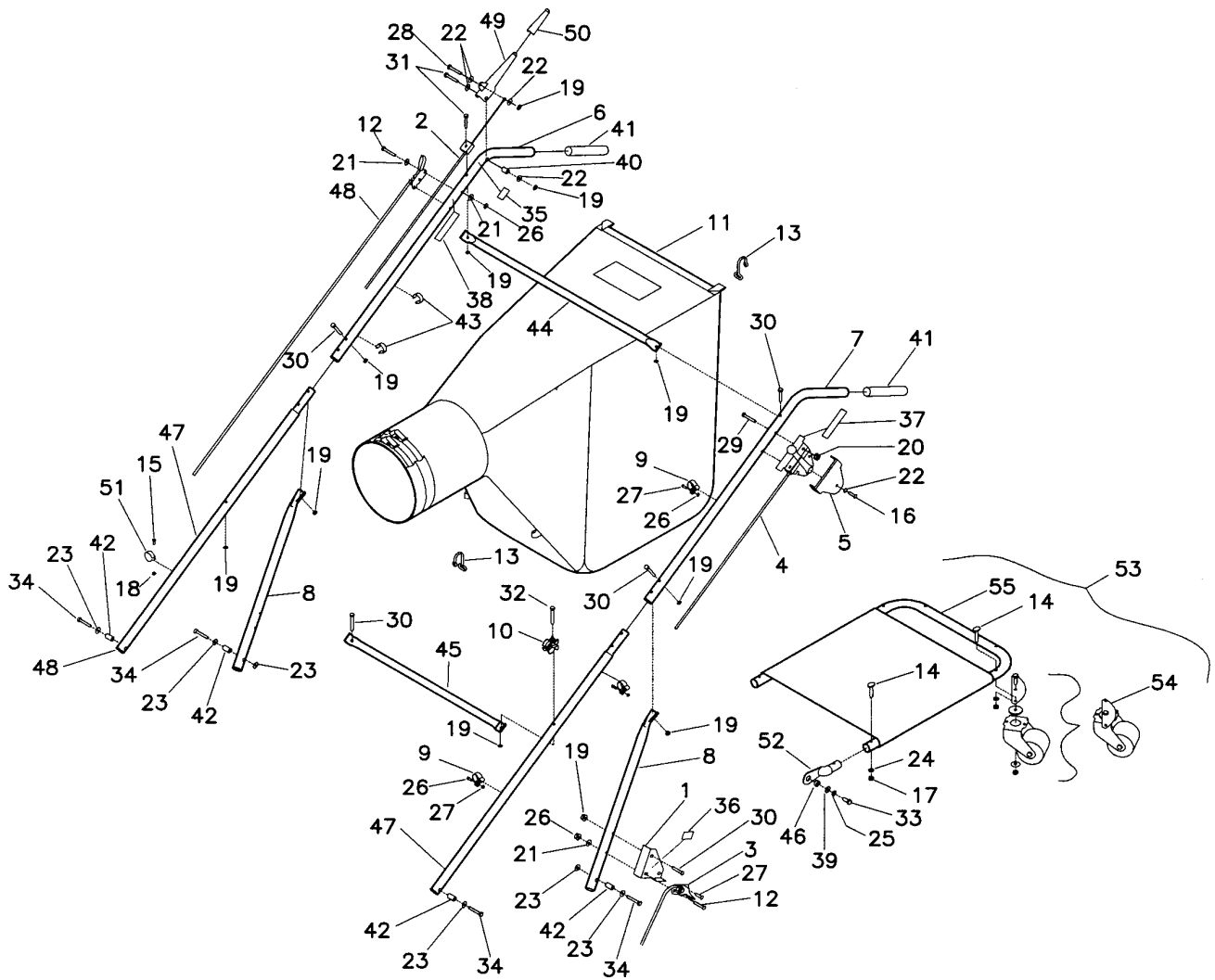

PARTS LIST

ITEM	PART NO.	REQ'D	DESCRIPTION
1	350114	1	BRAKE CABLE MOUNTING BRACKET
2	350124	1	CABLE CLUTCH SPVAC
3	350125	1	CABLE BRAKE SPVAC
4	350126	1	CABLE TRANS SPVAC
5	350143	1	PLASTIC COVER SHIFTER
6	350144	1	UPPER HANDLE RIGHT
7	350145	1	UPPER HANDLE LEFT
8	350147	2	SUPPORT BRACE LOWER
9	350174	3	SHIFT CABLE CLAMP
10	350186	1	KIT-ROPE GUIDE
11	350800	1	BAG, CLOTH PV W/LANARD419
12	515-10-24	3	SCR-RD HD 10-24 X 1 1/2
13	63-304-A	4	BAG HOOK
14	69-416-24	6	BLT-CONT HEAD 1/4-20 X 1.50
15	710130	1	SCR-MC 8-32 X .62 NICKEL
16	710178	1	SCR-MC TR HD 1/4-20 X .50 ZINC
17	711316	6	NUT-HEX 1/4-20 ST PL
18	711372	1	NUT-NYLOC 8-32
19	711373	11	NUT-NYLOC 1/4-20
20	711377	2	NUT-NYLOC 1/4-20
21	711503	5	WSR-FLT #10
22	711505	5	WSR-FLT 1/4
23	711506	6	WSR-FLT 5/16 (NARROW) ST PL
24	711544	6	WSR-HELICAL 1/4
25	711545	2	WSR-HELICAL 5/16
26	712638	7	NUT HEX 10-24 SS NYLOC
27	712811	4	SCR-MC 10-24 X .50 ZINC
28	713003	1	BLT-HH 1/4-20 X 1.00 #5
29	713004	2	BLT-HH 1/4-20 X 1.25 #5
30	713005	8	BLT-HH 1/4-20 X 1.50 #5
31	713007	2	BLT-HH 1/4-20 X 2.00 #5
32	713008	1	BLT-HH 1/4-20 X 2.25 #5
33	713027	2	BLT-HH 5/16-18 X 1 #5
34	713031	4	BLT-HH 5/16-18 X 2 #5
35	715302	1	DECAL-CLUTCH ENGAGE
36	715308	1	DECAL-PARKING BRAKE
37	715309	1	DECAL-SHIFT POSITION
38	715316	1	DECAL-THROTTLE CONTROL
39	76-36-A	2	WSR-SPECIAL
40	80-225-A	2	SPACER-.259 X .375 X 1.375
41	80-232-A	2	GRIP-HANDLE
42	80-238-A	4	BUSHING-.437 OD X 1.00 L ZINC
43	80-276-A	3	SNAP MOUNT
44	81-04-B	1	CROSSBAR UPPER
45	81-58-B	1	CROSSBAR BRACE
46	81-120-A	2	SPACER .316X.626X.210
47	82-242-B	2	MIDDLE HANDLE
48	83-25-B-54	1	CABLE-THROTTLE SPVAC
49	83-30-B	1	CLUTCH GRIP MACHINED
50	83-31-B	1	GRIP CLUTCH HANDLE
51	86-59-B	1	CLAMP CABLE /CLUTCH
52	92-22	2	METAL END CAP
53	MA-471-D	1	BAG PLATFORM
54	SA-1021-B	1	CASTER & PLATE ASY
55	SA-1023-C	1	FRAME AND PLATFORM ASY

TRACTION/FRAME ASSEMBLY SELF-PROPELLED MODEL

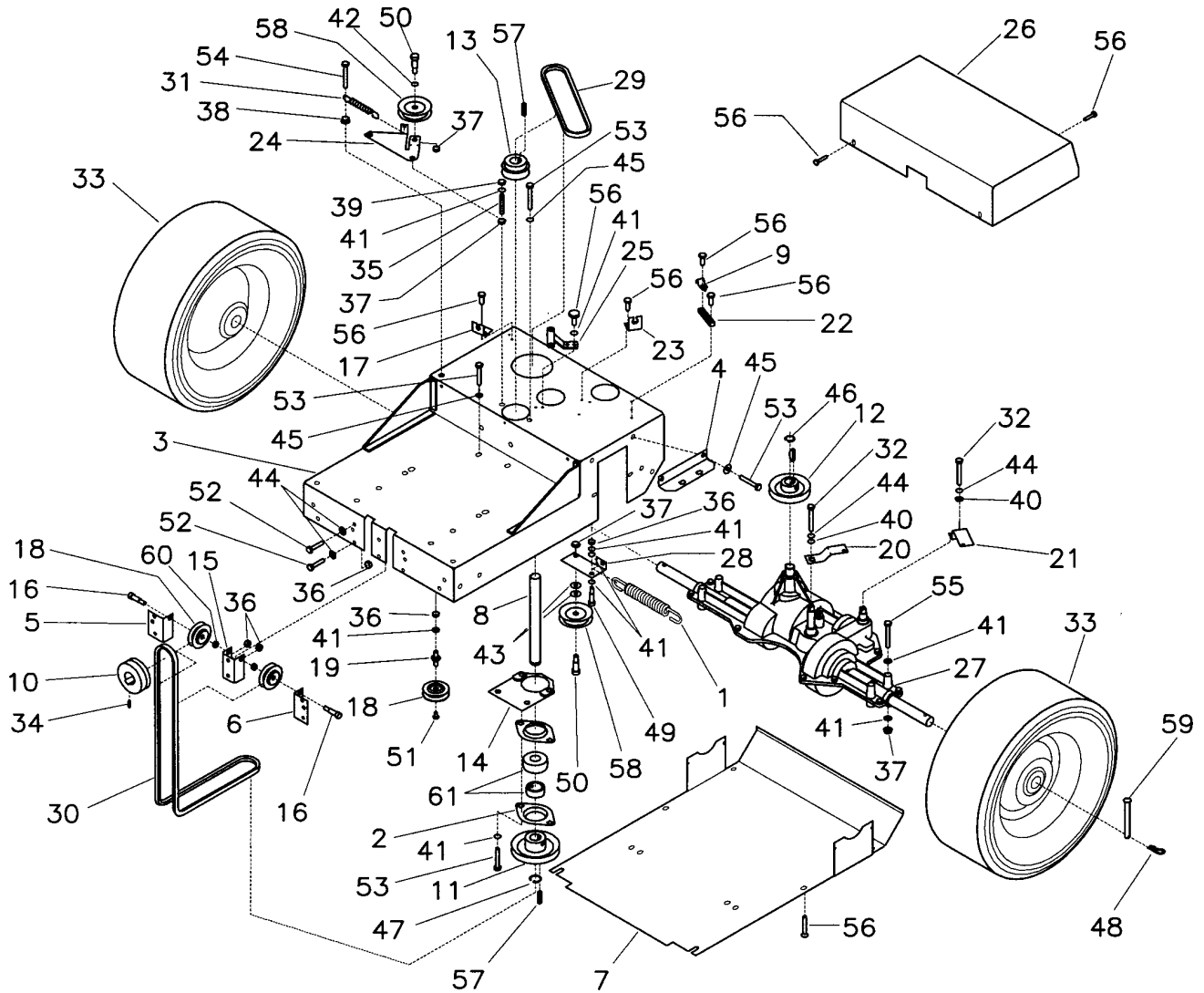

PARTS LIST

ITEM	PART NO.	REQ'D	DESCRIPTION
1	210035	1	SPRING-RETURN
2	340742	4	BEARING-FLANGE ZINC
3	350100	1	MAINFRAME
4	350106	2	TRANSMISSION MOUNTING BRACKET
5	350108	1	PULLEY BRACKET RH
6	350109	1	PULLEY BRACKET LH
7	350110	1	COVER BASE
8	350115	1	DRIVE SHAFT 3/4
9	350119	1	CLIP-CONDUIT
10	350120	1	PULLEY MOTOR
11	350121	1	PULLEY 3.5 X 3/4
12	350122	1	PULLEY 3" X 5/8 BORE
13	350123	1	PULLEY 2" X 3/4 AK20X3/4
14	350133	1	BEARING BRACKET
15	350134	1	PULLEY BRACKET CENTER
16	350146	2	SHOULDER SCREW
17	350151	1	CLUTCH CABLE MOUNTING BRACKET
18	350166	3	IDLER PULLEY ASY
19	350187	1	PULLEY STUD
20	350289	1	SHIFT LEVER
21	350290	1	BRAKE LEVER
22	350291	1	BRAKE BRACKET
23	350292	1	BRACKET TRANS CABLE
24	350293	1	CLUTCH LEVER
25	350294	1	BRACKET BELT GUIDE
26	350295	1	TOP COVER
27	350300	1	TRANSMISSION W/BRAKE
27A	350299	1	TRANSMISSION W/REVERSE
28	350304	1	TENSIONER ENG DR
29	350305	1	BELT-DUNLOP 3L200
30	350306	1	BELT-GOODYEAR 3L520
31	350308	1	SPRING-RETURN CLUTCH .750 X 2.
32	60-416-10	2	BLT-HH 1/4-28 X 5/8 #5
33	68-310-B	2	WHEEL SPVAC
34	711016	1	SK 1/4-20 X .50
35	711047	1	SK 5/16-18 X 1.50
36	711373	6	NUT-NYLOC 1/4-20
37	711374	7	NUT-NYLOC 5/16-18
38	711379	1	NUT-FLANGED WIZZ 5/16-18
39	711383	1	NUT-HEX CTR LOC 5/16-18
40	711505	3	WSR-FLT 1/4
41	711506	15	WSR-FLT 5/16 (NARROW) ST PL
42	711507	1	WSR-FLT .37 X 1.12 X .06
43	711523	2	WSR-WAVE .37 X .68 X .08
44	711544	8	WSR-HELICAL 1/4
45	711545	7	WSR-HELICAL 5/16
46	711714	1	RET RING-EXT .62
47	711715	1	RET RING-EXT .75
48	711808	2	PIN-HAIRPIN COTTER #13
49	712041	1	BLT-SHOULDER 1/4-20 X .44 X .37
50	712081	2	BLT-SHOULDER 5/16-18 X .75 X .37
51	712540	1	SCR-MC 10-24 X .37 SS TH
52	713002	6	BLT-HH 1/4-20 X .75 #5
53	713027	9	BLT-HH 5/16-18 X 1 #5
54	713033	1	BLT-HH 5/16-18 X 2 1/2 #5
55	713034	4	BLT-HH 5/16-18 X 2 3/4 #5
56	72-416-10	19	BLT ST 1/4 X 5/8
57	762375	2	KEY,.187 SQ X .78
58	76-456-A	2	CLUTCH PULLEY AS REC
59	80-44-A	2	PIN-CLEVIS
60	82-135-A	2	SPACER-.316 X .498 X .197
61	881059	2	BEARING-COLLAR .75 (2PC)

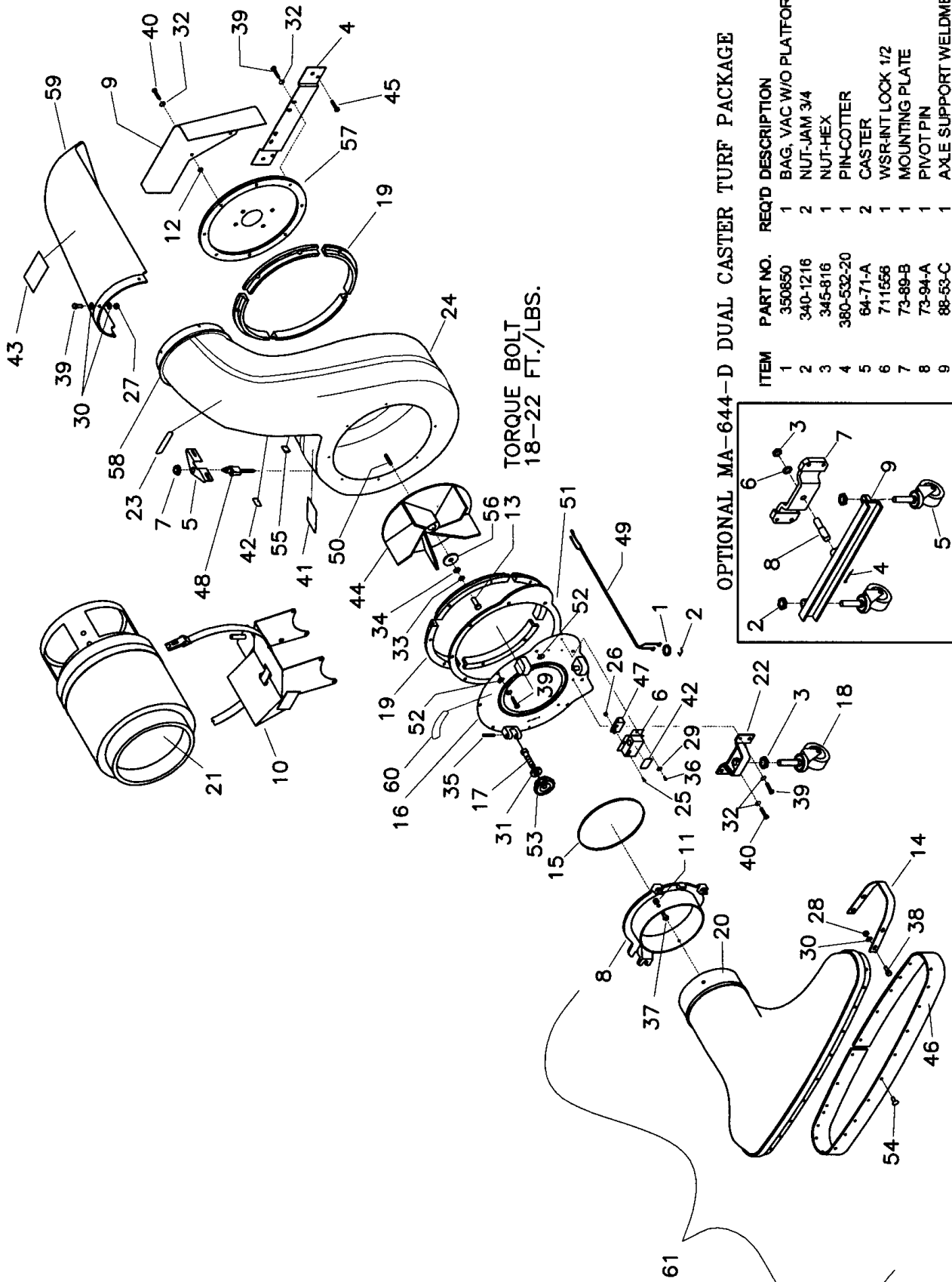

PARTS LIST

ITEM	PART NO.	REQ'D	DESCRIPTION
1	101008	1	GROMMET, RUBBER
2	250136	1	STRAIN RELIEF
3	340-1216	1	NUT-JAM 3/4
4	350128	1	HOUSING SUPPORT
5	350129	1	SWITCH BRACKET FOR 7050-10
6	350130	1	SWITCH BRACKET 6400
7	350135	1	SWITCH NUT 6250
8	350152	1	COLLAR
9	350275	1	HEAT SHIELD VAC35 LP
10	350285	1	TANK BRACKET ASSY VAC35LP
11	369-416	4	NUT-NYLOC SERATED 1/4-20
12	54-227-A	2	SPACER-.328 X .50 X .156
13	60-516-24	1	BLT-HH 5/16-24 X 1.5 #5
14	62-98-C	2	GUARD
15	63-190-A	1	O RING GASKET
16	63-191-D	1	CASTING-COVER FRONT
17	63-192-A	1	PIVOT BOLT
18	64-71-A	1	CASTER
19	64-78-C	8	ANTI-WRAP SEGMENTS
20	65-567-F	1	INTAKE HOUSING 24"
20A	77-18-F	1	INTAKE HOUSING 30"
20B	MA-121	1	INTAKE HOUSING 36"
21	65-747-B	1	L.P. TANK 20LB. VAPOR
22	66-430-C	1	CASTER BRACKET
23	67-08-A	1	DECAL-SPIN PAK
24	70-103-F	1	HOUSING BLOWER VAC35
25	710130	2	SCR-MC 8-32 X .62 NICKEL
26	711372	2	NUT-NYLOC 8-32
27	711373	4	NUT-NYLOC 1/4-20
28	711377	8	NUT-NYLOC 1/4-20
29	711503	3	WSR-FLT #10
30	711505	20	WSR-FLT 1/4
31	711509	1	WSR-FLT 1/2
32	711544	18	WSR-HELICAL 1/4
33	711565	1	WSR-EXT LOCK 5/16
34	711575	1	WSR-FLT .31 X .75 X .06 STL
35	711661	1	PIN-ROLL .250 X 1 3/4
36	712810	3	SCR-MC 10-24 X .37 ZINC
37	713001	4	BLT-HH 1/4-20 X .62 #5
38	713002	12	BLT-HH 1/4-20 X .75 #5
39	713003	14	BLT-HH 1/4-20 X 1.00 #5
40	713004	2	BLT-HH 1/4-20 X 1.25 #5
41	715300	1	DECAL-WARNING FINGERS
42	715313	1	DECAL-SAFETY INTER LOC
43	715318	1	DECAL-DANGER
44	72-175-D	1	FAN WHEEL 1" BORE 8HP
45	72-416-10	4	BLT ST 1/4 X 5/8
46	73-67-D	1	SKIRT 30" HOUSING
46A	73-74-D	1	SKIRT 36" HOUSING
46B	73-76-C	1	SKIRT 24" HOUSING
47	740282	1	SWITCH-DELTA 6451
48	741031	1	SWITCH BAG SAFETY KAWASAKI
49	740291	1	WIRE ASSEMBLY
50	74-112-A	1	KEY-1/4 X 1/4 X 2 1/2 (SP MODEL)
50A	63-130-A	1	KEY-1/4 X 1 3/4 LONG MAN. MODEL)
51	75-03-C	1	GASKET FRONT COVER
52	78-120-A	2	CLAMP-P
53	80-29-A	1	KNOB-PLASTIC
54	80-332-A	15	XMAS TREE FASTNER
55	809443	1	CLIP-WIRE & CORD
56	82-138-B-3	1	WSR-AREA VAC 35
57	84-346-C	1	BACK PLATE & GASKET,PV-8
58	85-59-C	1	RETAINING RING MACHINED
59	85-61-D	1	SPIN PAC DEFLECTOR
60	85-151-A	1	DECAL-STOP FAN BEFORE
61	MA-113-D	1	24" INTAKE HOUSING
61A	MA-120-D	1	36" INTAKE HOUSING COMP
61B	SA-911-D	1	INTAKE ASSY 30" VAC35

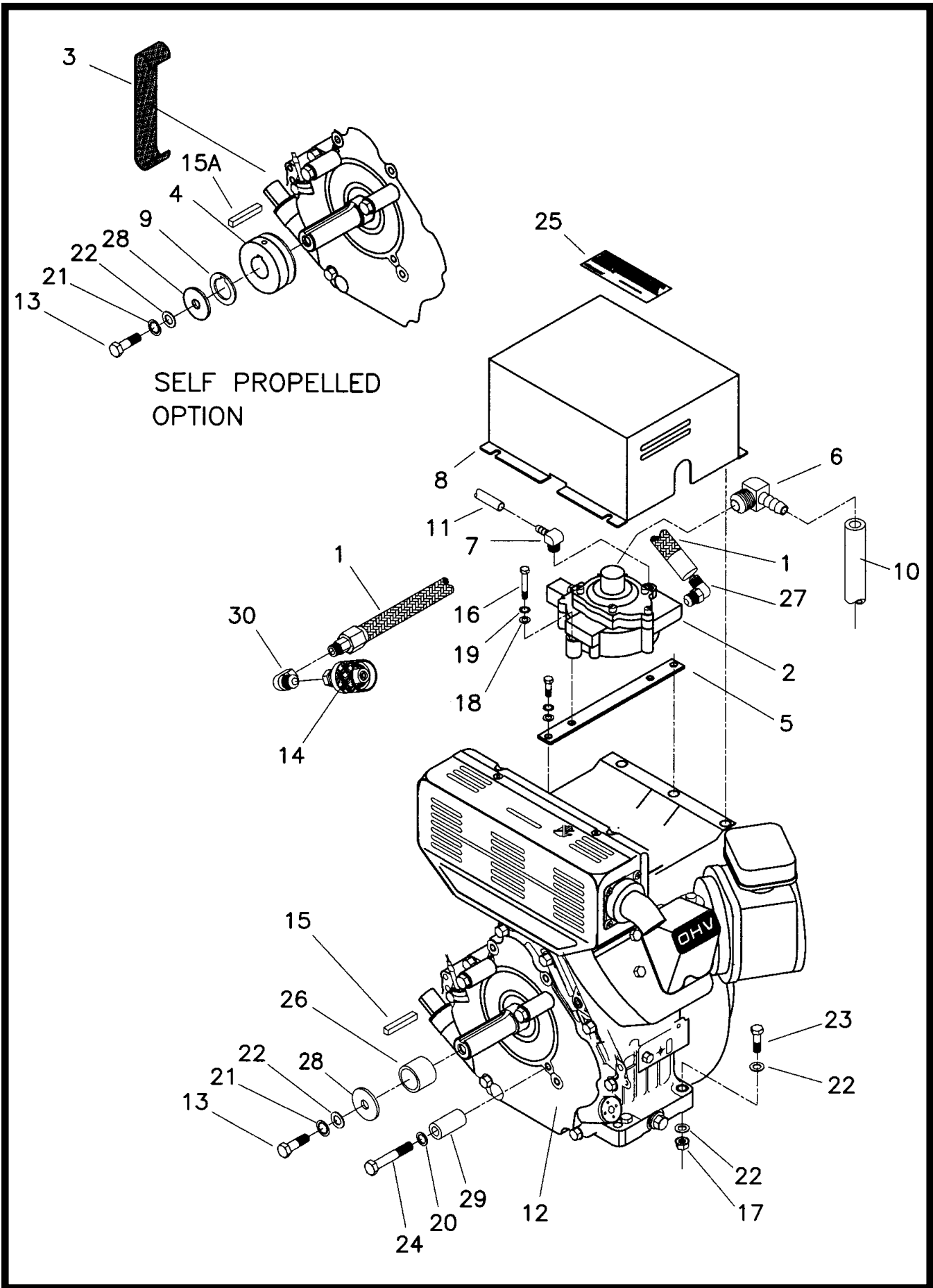

PARTS LIST

ITEM	PART NO.	REQ'D	DESCRIPTION
1	220070	1	HOSE-HIGH PRESSURE
2	220217	1	REGULATOR
3	350112	2	FINGER GUARD
4	350120	1	PULLEY MOTOR
5	350278	1	BRACKET-REGULATOR N51-A
6	350279	1	FITTING-90 3/8MPT 3/8HOSE BRASS
7	350280	1	FITTING-1/8MPT 1/8BARB BRASS
8	350283	1	COVER REGULATOR VAC35 LP
9	350284	1	SPACER-ARBOR 1" 1/4" KEY STL
10	350310	1	HOSE LP 13"-3/8"DIA
11	350311	1	HOSE VACUUM 13"-5/32"DIA
12	350550	1	ENGINE-8HP KAW FE250D-S05-01
13	60-516-24	1	BLT-HH 5/16-24 X 1.5 #5
14	62-252-A	1	CONNECTOR-SAFETY FEMALE
15	63-130-A	1	KEY-1/4 X 1 3/4 LONG (MAN. MODEL)
15A	74-112-A	1	KEY-1/4 X 1/4 X 2 1/2 (SP MODEL)
16	711210	2	BLT-HH 1/4-20 X 1.25 STL ZINC
17	711379	4	NUT-FLANGED WIZZ 5/16-18
18	711505	2	WSR-FLT 1/4
19	711544	2	WSR-HELICAL 1/4
20	711546	4	WSR-HELICAL 3/8
21	711565	1	WSR-EXT LOCK 5/16
22	711575	9	WSR-FLT .31 X .75 X .06 STL
23	713029	4	BLT-HH 5/16-18 X 1 1/2 #5
24	713047	4	BLT-HH 3/8-16 X 2.25 #5
25	715277	1	DECAL-EMISSIONS 8HP KAW
26	72-179-A	1	SPACER-1 X 1.312 X 1.032
27	80-113-A	1	90 MALE EL FLARED 428-03
28	82-138-B-3	1	WSR-AREA VAC 35
29	82-151-A	4	SPACER-.406 X .75 X 1.5
30	831306	1	FITTING-90 1/4MPT 1/4FPT BRASS

LIMITED WARRANTY

The Parker Sweeper Company warrants to the original purchaser/user that this product is free from defects in workmanship and materials under normal use and service for a period of two years from date of purchase. In addition, Parker Sweeper Company will, at its option, honor labor warranty claims for the first 12 months from date of sale, provided such claims are submitted through and approved by factory authorized repair stations. Parker Sweeper Company will, at its option, repair or replace without charge, except for transportation costs, parts that fail under normal use and service when operated and maintained in accordance with the applicable operation and instruction manuals.

This warranty does not apply to normal wear, or to items whose life is dependent on their use and care, such as belts, cords, switches, hoses, rubber parts, electrical motor components or adjustments. Parts not manufactured by Parker Sweeper Company such as engines, batteries, battery chargers, hydraulic pumps, and tires are covered by and subject to the warranties and/or guarantees of their manufacturers. Please contact Parker Sweeper Company for procedures in warranty claims against these manufacturers.

Special warning to purchaser — Use of replacement filters and/or prefilters not manufactured by Parker Sweeper Company or its designated licensees, will void all warranties expressed or implied.

A potential health hazard exists without exact original equipment replacement.

All warranted items become the sole property of Parker Sweeper Company or its original manufacturer, whichever the case may be.

Parker Sweeper Company disclaims any implied warranty, including the warranty of merchantability and the warranty of fitness for a particular purpose. Parker Sweeper Company assumes no responsibility for any special, incidental or consequential damages.

This limited warranty is applicable only in the U.S.A. and Canada, and is extended only to the original user/purchaser of this product. Customers outside the U.S.A. and Canada should contact their local distributor for export warranty policies. Parker Sweeper Company is not responsible for costs or repairs performed by persons other than those specifically authorized by Parker Sweeper Company. This warranty does not apply to damage from transportation, alterations by unauthorized persons, misuse or abuse of the equipment, use of non-compatible chemicals, or damage to property, or loss of income due to malfunctions of the product.

If a difficulty develops with this machine, you should contact the dealer from whom it was purchased.

This warranty gives you specific legal rights, and you may have other rights which vary from state to state. Some states do not allow the exclusion or limitation of special, incidental or consequential damages, or limitations on how long an implied warranty lasts, so the above exclusions and limitations may not apply to you.

Minuteman[®]
Parker[®]

A Member of the Hako Group of Companies

World Headquarters

Minuteman International, Inc.
111 South Rohlwing Road
Addison, Illinois 60101

Phone 630-627-6900

Fax 630-627-1130

www.minutemanintl.com

Minuteman Canada, Inc.

2210 Drew Road
Mississauga, Ontario
L5S 1B1

Phone 905-673-3222

Fax 905-673-5161

988202

Printed in U.S.A.