

Minuteman[®]
Parker[®]

Model:
PV-9308BSP
PV-9308HSP
PV-0285KSP

Vac 35
Self Propelled

OPERATION

SERVICE

PARTS

CARE

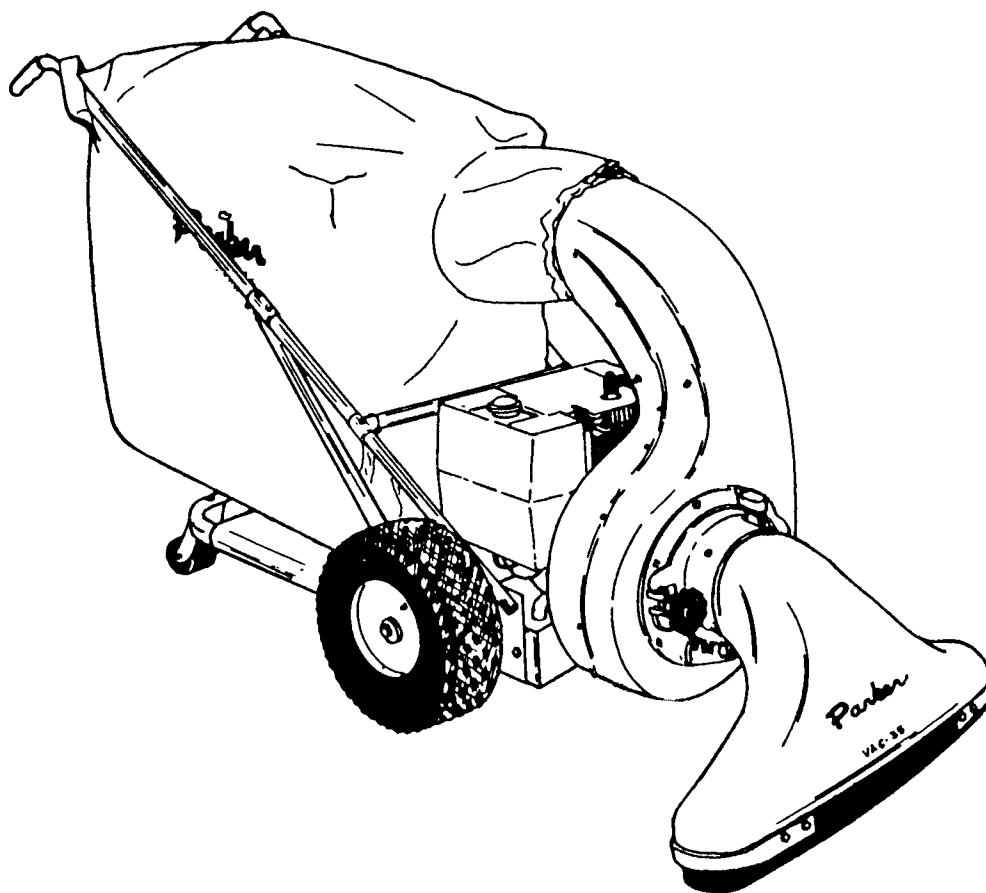

TABLE OF CONTENTS

1 & 2	General Safety Instructions
3	Warning Decal Replacement
4	Assembly Operating Instructions
5	Handle Assembly Instructions
6	Transport Drive/Parking Brake
7	Safety Interloc System
8	Accessories
9 -11	Repair Parts, Engine
12 - 13	Repair Parts, Handle Assembly
14 - 15	Repair Parts, Traction System
16 - 17	Repair Parts, Blower Assembly

Model # _____ Serial # _____



DECLARATION OF CONFORMITY

MANUFACTURER'S NAME: Minuteman International Inc.

MANUFACTURER'S ADDRESS: 111 South Rohlwing Road
Addison, IL. 60101

EQUIPMENT DESCRIPTION: VAC 35 SELF PROPELLED

EQUIPMENT MODEL DESIGNATION: PV0285KSP, PV0285KSPD

Application of Council Directives: 89/392/EC, 2000/14/EC, 91/368/EC, 98/37/EC

Harmonized EN standards complied with: EN 292

Additional Standards: ISO 3744, ISO 11094

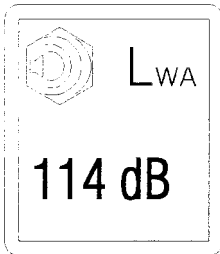

I, the undersigned, hereby declare that the equipment specified above conforms to the above Directive(s) and Standard(s).

SIGNATURE:

Jeffrey Pollack

DATE: *April 24, 2004*

PRINTED NAME:
TITLE:

Jeffrey Pollack
Standards Engineer

IMPORTANT SAFETY INSTRUCTIONS

READ ALL INSTRUCTIONS BEFORE USING

WARNING

- To prevent personal injury or property damage, do not attempt to start engine until all assembly steps are complete and you have read and understand the safety and operating instructions in this manual.
- Under California law, and under laws of several other states, you are not permitted to operation internal combustion's engine using hydrocarbon fuels on any forest covered, brush covered, or grass covered land, or on land with grain, hay, or other flammable agricultural crop, without an engine spark arrester in continuous effective working order. The engine on your power equipment, like most outdoor power equipment, is an internal combustion engine that burns gasoline, a hydrocarbon fuel. Therefore, your power equipment must be quipped with a spark arrester muffler in continuous effective working order. The spark arrester must be attached to the engine exhaust system in such a manner that flames or heat from the system will not ignite flammable material. Failure of the owner/operator of the equipment to comply with this regulation is a misdemeanor under California law, and may also be a violation of other state and/or federal regulations, laws, ordinances, or codes. Contact your local fire marshal or forest service for specific information about what regulations apply in your area.
- Wear approved safety glasses when operating this equipment. The operation of any powered machine can result in foreign objects being thrown by high-speed rotating parts.
- Wear work gloves, sturdy footwear, and hearing protection when operating this equipment.
- Remove hearing protection and watch for traffic when operating near, or when crossing roadways.
- Before inspecting or servicing any part of equipment, shut off engine, disconnect spark plug wire from spark plug, and make sure that all moving parts have come to a complete stop. Be aware that rotating blades slow down gradually after engine is shut off.
- Exercise extreme caution on slopes and avoid excessively steep slopes.
- Never leave equipment unattended when engine is running. Shut off engine and disconnect spark plug wire from spark plug before leaving equipment. Turn off fuel shut-off if equipped.
- Do not blow any burning or smoldering materials such as cigars, cigarettes, ashes, or cinders.
- Do not blow areas that have been recently treated with fertilizers, pesticides, or herbicides. Follow chemical manufacturer's safety instructions regarding contact with treated areas.
- Keep in mind that the operator or user is responsible for accidents or hazards occurring to other people or their property.
- Thoroughly inspect the areas where the equipment is going to be used, and remove all objects that may be a hazard when thrown.
- Never pick up or carry equipment while the engine is running.
- Walk, never run.
- Never allow children or untrained adults to operate this equipment.
- Keep the area of operation clear of all persons, particularly small children, and pets. Keep bystanders at least 25 feet away from the area of operation.

- Do not run engine in an enclosed area. Engine exhaust contains carbon monoxide gas, a deadly poison that is odorless, colorless, and tasteless.
- Do not operate this equipment near buildings, windows, or air conditioners.
- Do not allow hands or any other part of the body or clothing inside the vacuum inlet.
- Do not start engine or operate this equipment with any safety guards or housing removed.
- Operate machine in daylight or good artificial light.
- Do not change the engine governor settings or overspeed the engine.

DANGER

Gasoline is highly flammable and its vapors are explosive. To prevent personal injury or property damage:

- Do not add fuel if engine is running or still hot from recent operation. Allow engine to cool for at least three minutes.
- Do not fill fuel tank indoors. After filling, wipe up any spills and move away from gasoline fumes before starting engine.
- Do not allow open flame, matches, or smoking in area.
- Fill fuel tank with fresh, clean unleaded regular automotive gasoline, (leaded regular and unleaded or leaded premium grades of gasoline are acceptable substitutes).
- Do not mix oil with gasoline.
- Clean the area around the fuel fill cap and remove the cap from the fuel tank. Insert a clean funnel into the fuel tank.
- Fill the tank to 1/2 inch below the bottom of the filter neck to provide space for any fuel expansion.
- Reinstall the fuel fill cap securely and wipe up any spilled gasoline.
- Store fuel in containers specifically designed for these purposes.
- Replace faulty silencers or mufflers and muffler guards.
- Before using, visually inspect to see that the blade and blade bolts are not worn or damaged and, if needed, replace in sets.
- Do not start the engine when standing in front of the discharge chute.
- Drain fuel outdoors.

SAVE THESE INSTRUCTIONS

SAFETY DECALS

FOR KOHLER ENGINES.

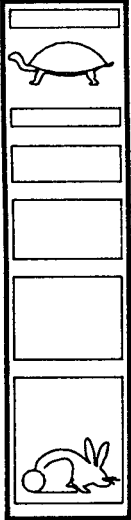

92-30

FOR HONDA AND BRIGGS ENGINES.

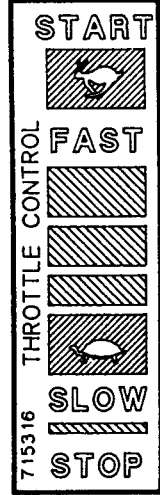

715316

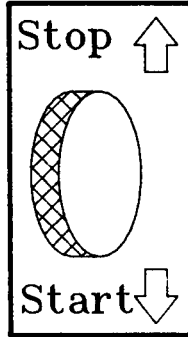

715302

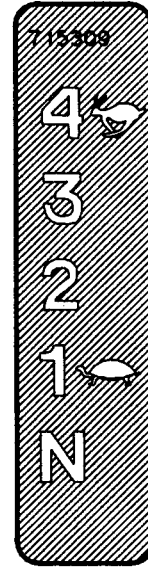

715309

DO NOT OPEN OR REMOVE SAFETY SHIELDS WHILE ENGINE IS RUNNING

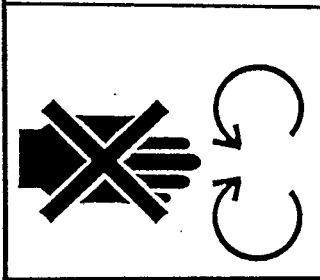
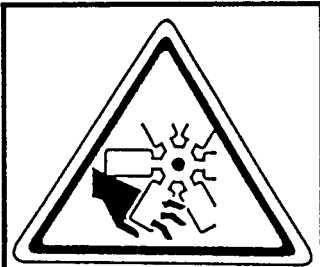

715300

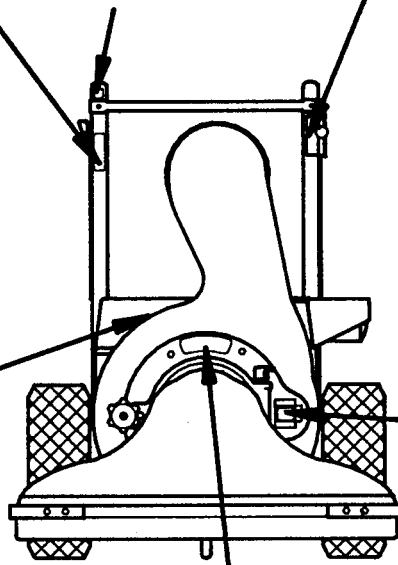

715313

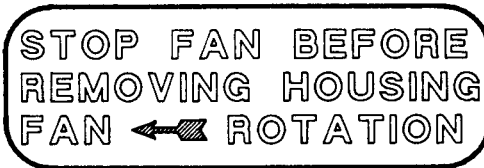

85-151-A

OPERATING INSTRUCTIONS

READ SAFETY OPERATING INSTRUCTIONS BEFORE OPERATING EQUIPMENT

1. Heavy concentration of sand and gravel should be avoided. These materials are extremely abrasive, and while the VAC 35 will handle moderate amounts of these materials, it is not designed for heavy applications. Treat your VAC 35 with reasonable care and it will repay you with long, trouble-free service.
2. The VAC 35 will handle most common kinds of debris found around industrial plants, commercial buildings, homes, and farms. Acid contaminated materials, magnesium, dust, and other DANGEROUS DEBRIS that is considered hazardous should not be handled with the VAC 35.
3. The efficiency of this unit depends on the breathing capacity of the dust bag. Under extremely dusty conditions the bag should be emptied and cleaned frequently. Always empty and clean bag before storing after use. Debris allowed to remain in the bag may cause spontaneous combustion, resulting in an explosion or fire. See instructions supplied with dust bag.
3. When Clean, Turn bag right side out and reattach to unit.
4. Bag can be washed if extremely dirty.

TO START UNIT

IMPORTANT: Read the Engine Manual CAREFULLY before operating the VAC 35. Before starting the engine read and understand the following:

1. Be sure the engine crankcase is filled with the proper type and amount of oil.
2. Spin-Pak[®] is in place.
3. Dust bag or discharge hose is in place.
4. Intake housing or hose kit is attached to the fan housing.

TO STOP THE ENGINE

To stop the engine, Briggs & Stratton equipment, move the Engine Throttle Control to the STOP position. For Honda equipment, reduce engine speed to slow, turn engine STOP control to off on side of engine. Remove any hearing protection and listen for all moving parts to come to a complete stop.

DUST BAG CARE

1. To clean dust bag, turn the bag inside out and reattach to unit.
2. Start engine and run at full throttle. Lightly tap bag to release dirt trapped in the weave.

LUBRICATION

Add a few drops of oil to the throttle control cable and wire to help keep it operating smoothly.

Clearing the Machine of Clogs and Jams

A clog or jam in the machine can cause the vacuuming operation to decrease or even stop completely. If this occurs, take the following steps:

1. STOP THE ENGINE IMMEDIATELY and disconnect the spark plug wire from the spark plug. Wait for all moving parts to come to a complete stop.
2. Check (and clean, if necessary) the following areas in this order:
 - Check that the collection bag is not overfilled. Remove and empty bag.
 - While the bag is removed, check that the discharge deflector is not clogged or jammed. Use a stick to clear away any debris.
 - Check that the vacuuming attachment is not clogged or jammed. Remove the attachment and thoroughly clean the opening. While the attachment is removed, check the inlet opening to the machine. Use a stick to clear away any debris.

HANDLE ASSEMBLY INSTRUCTIONS

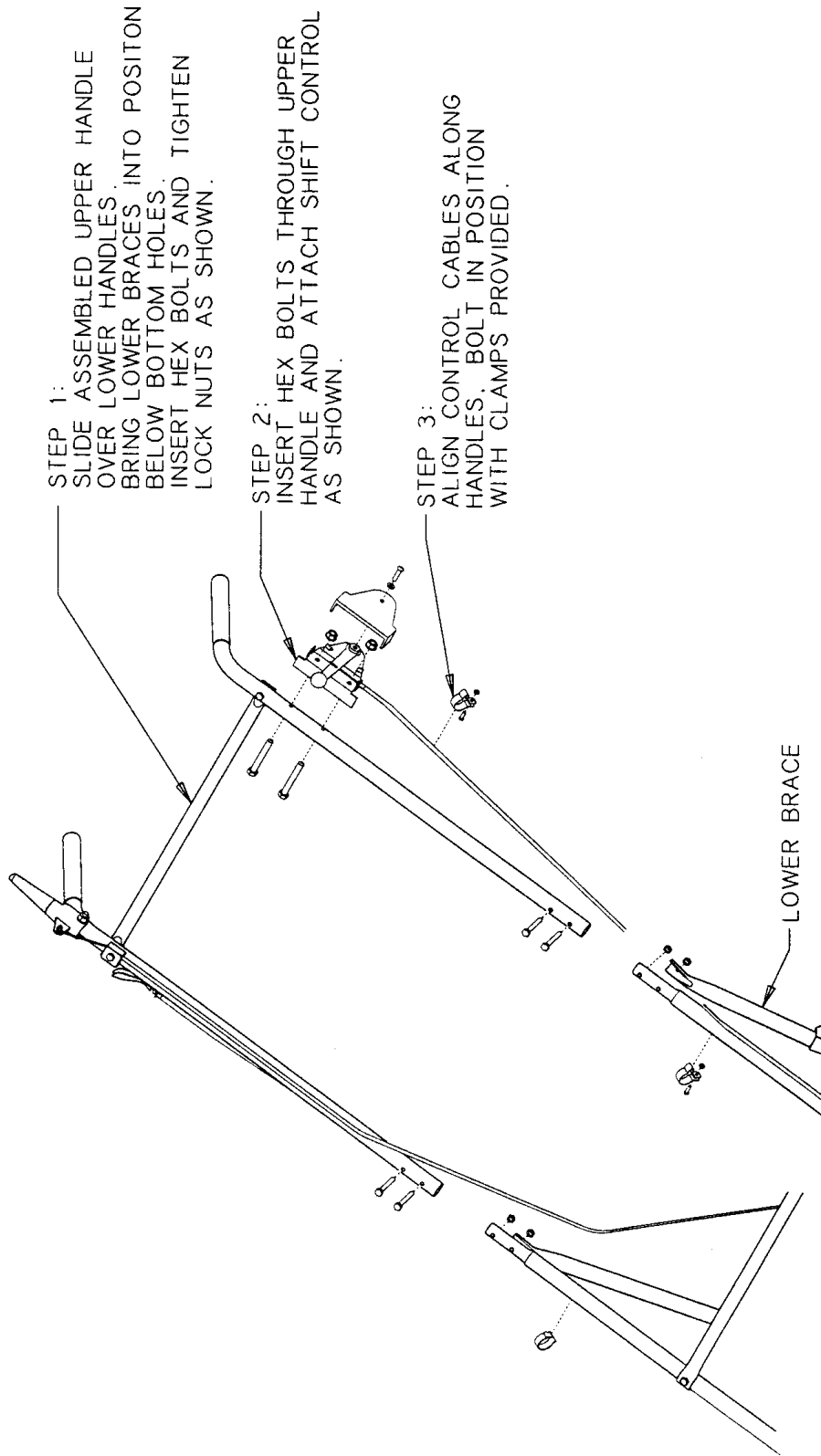

Figure 1

TRANSPORT DRIVE/PARKING BRAKE

Transport Drive

- Operate the machine in a large, level, open area until you are familiar with its operation. Begin with speed No. 1 and gradually work up to speed No. 4. (Figure 1)
- To avoid damaging the transmission, always release the Clutch Lever (Figure 2) and wait for the wheels to stop before shifting gears.
- Forward momentum may cause the machine to gradually coast to a stop after the Wheel Drive is released (especially when in 3rd or 4th gear). Allow for this coasting distance when stopping the machine.
- Engage the Clutch Lever slowly when starting off in 3rd or 4th gear. The machine may hesitate briefly before the wheels begin turning.
- Shift to a lower forward gear if the wheel loses traction when going up a slope (always avoid excessively steep slopes). Before shifting, turn the machine sideways on the slope to prevent rolling of the machine and to relieve strain on the transaxle.
- Never force the shift lever as damage may result.
- If shifting is difficult, it may be necessary to manually move the machine a few inches forward or backward while moving the shift lever.

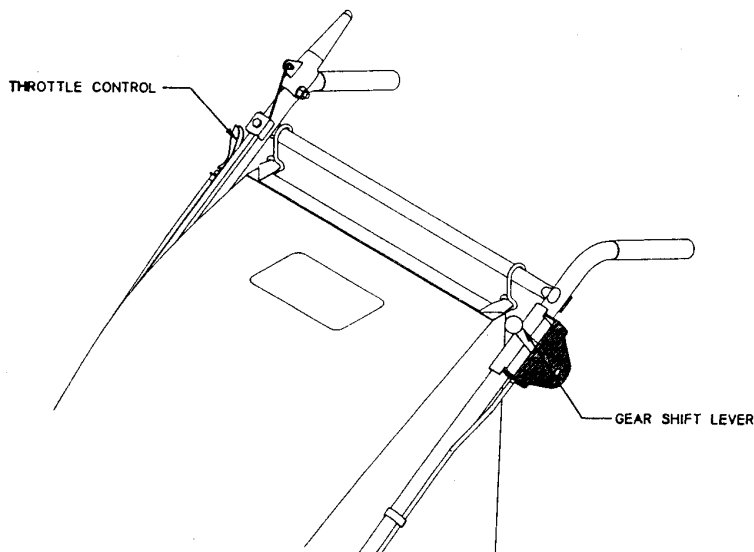

Figure 1

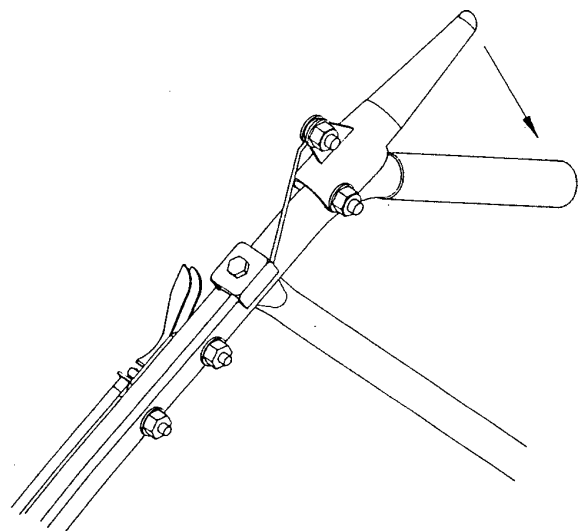
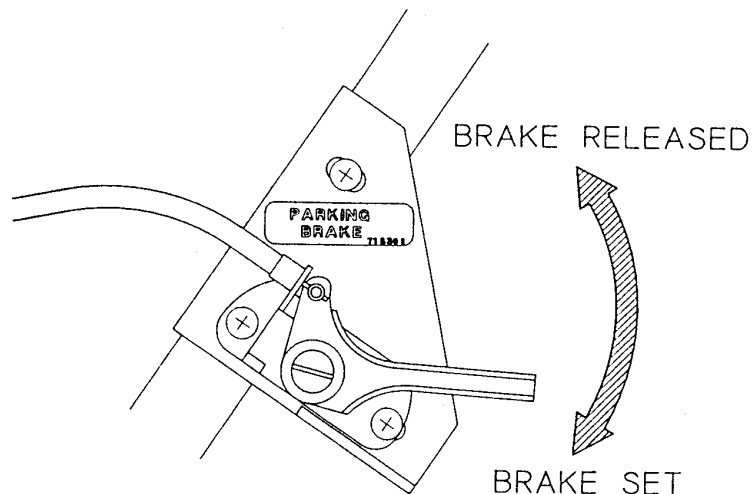

Figure 2

Parking Brake

Located on left side of machine.
Lower handle section - parking brake
should be used on level surfaces.
The parking brake not intended to
hold machine on slopes or inclines.



SAFETY INTERLOC SYSTEM

This equipment incorporates two safety interloc systems. Figure 1 below is for the front vacuum Housing Assembly. Figure 2 is for the Cloth Bag Assembly. Both interlocs must be engaged for engine to start.

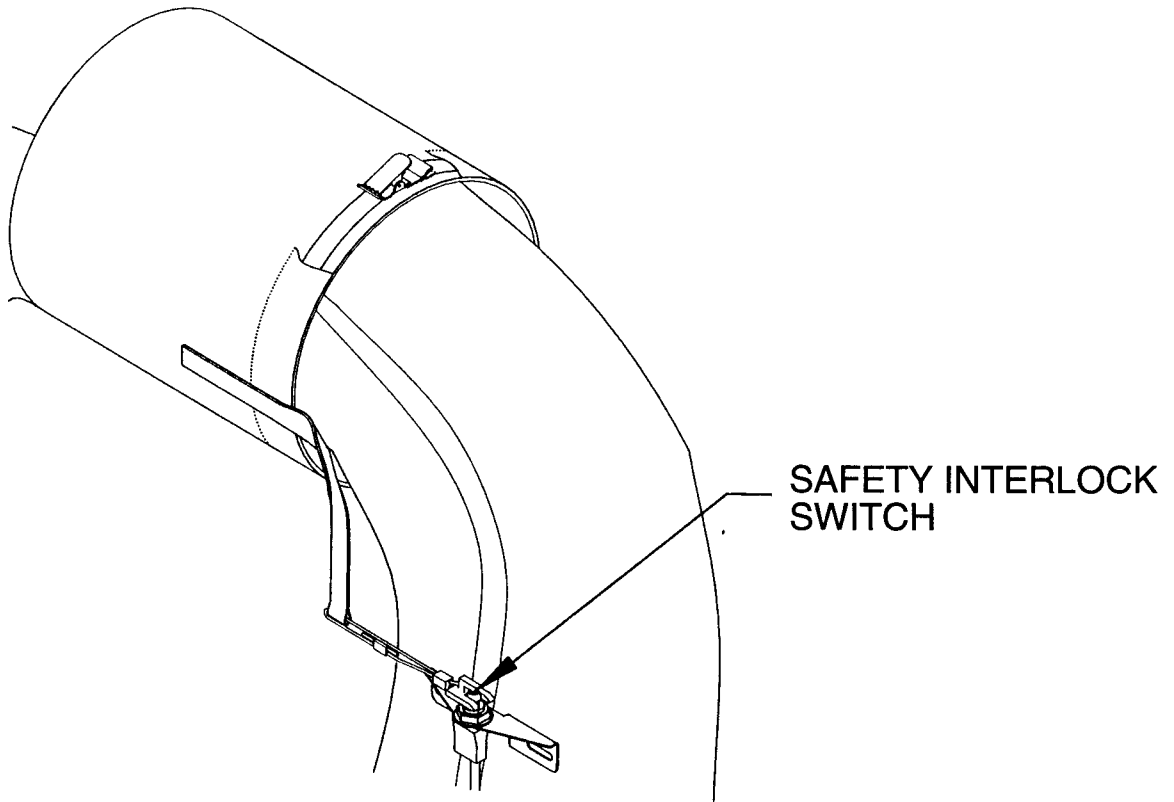
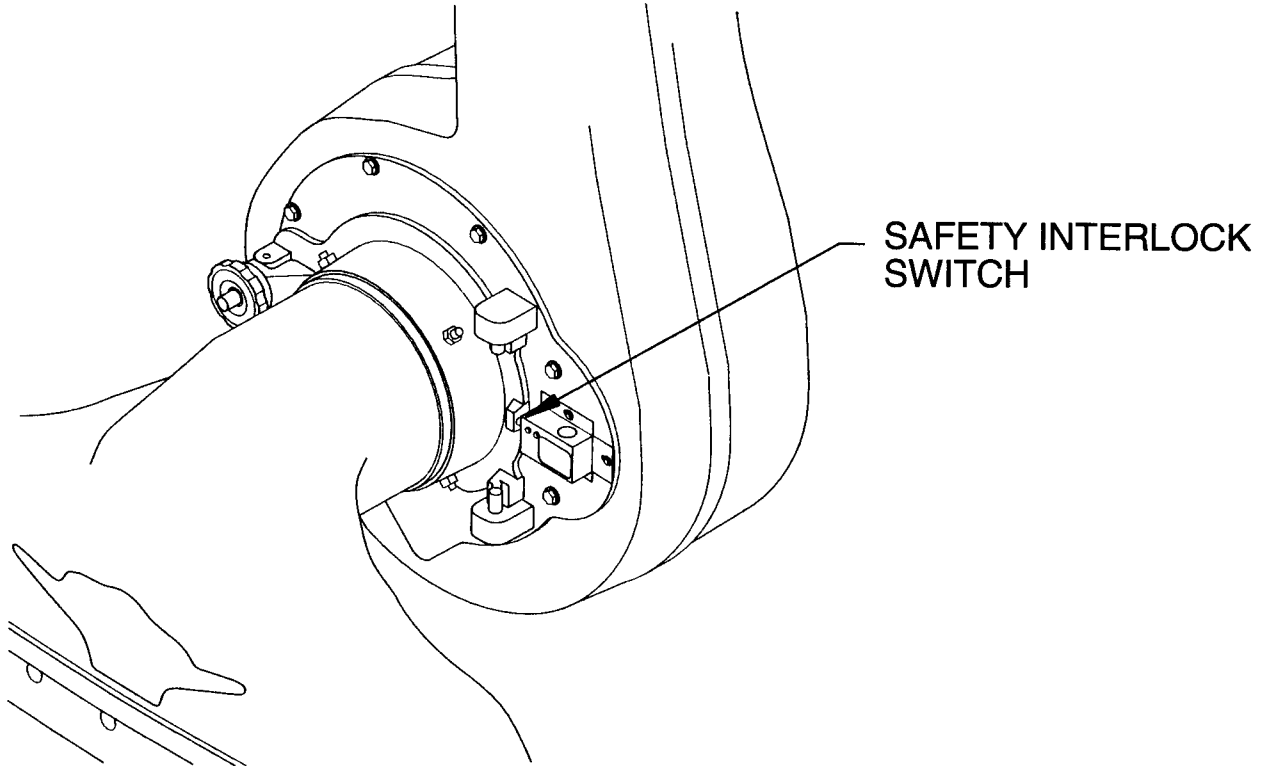

ACCESSORIES

MA-620-D 8 IN. HOSE KIT
MA-578-D 6 IN. HOSE KIT
MA-622-D 4 IN. HOSE KIT

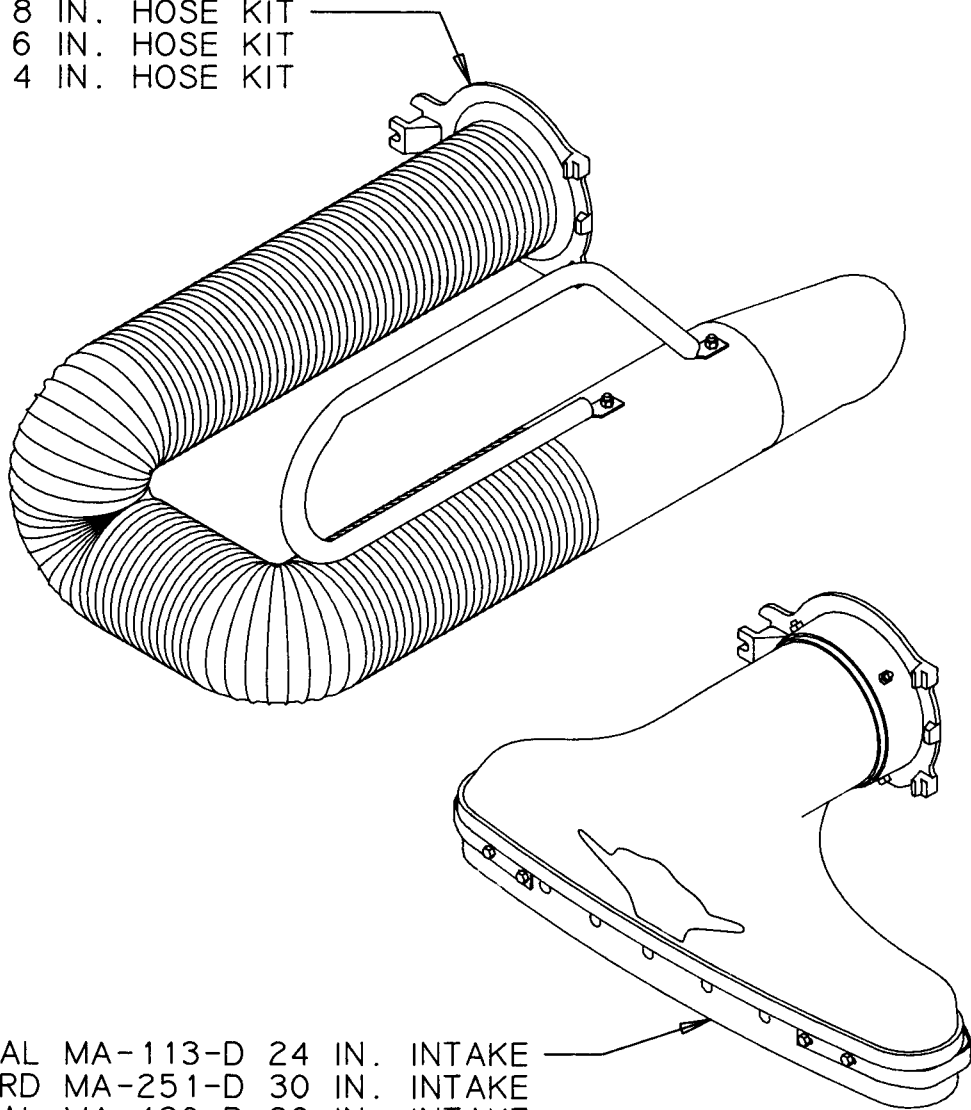

OPTIONAL MA-113-D 24 IN. INTAKE
STANDARD MA-251-D 30 IN. INTAKE
OPTIONAL MA-120-D 36 IN. INTAKE

HONDA

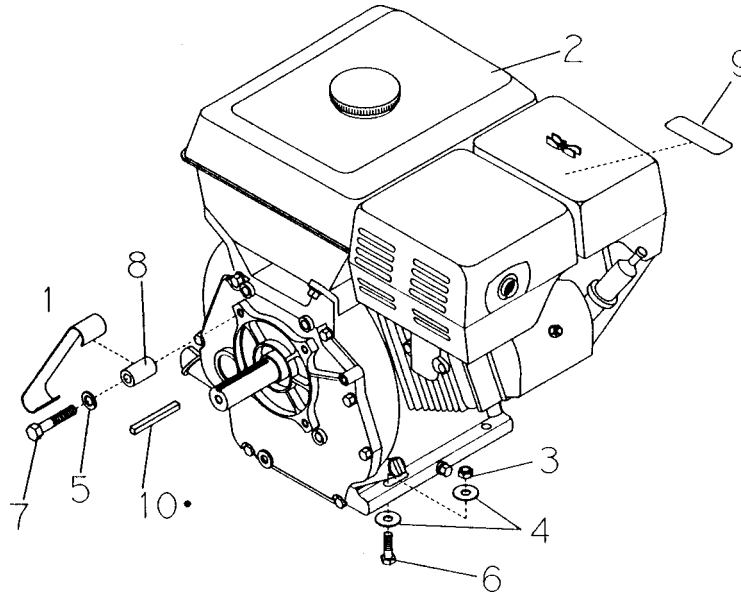

PARTS LIST

Item	Part No.	Qty.	Description
1	350112	2	Finger Guard
2	350500	1	8 HP Honda Engine
3	711380	4	3/8-16 Nyloc Nut
4	711508	8	.44 x 1.00 Flatwasher
5	711546	4	3/8 Helical Washer
6	713045	4	3/8-16 x 1.75 Hex Bolt (Grd. 5)
7	713047	4	3/8-16 x 2.25 Hex bolt (Grd. 5)
8	350150	4	.406 x .75 x 1.38 Spacer
9	715314	1	Muffler Decal
10	74-112-A	1	1/4 x 1/4 x 2 1/2 Key
	350120	1	Engine Pulley
	350186	1	Rope Guide

ENGINE ON/OFF SWITCH

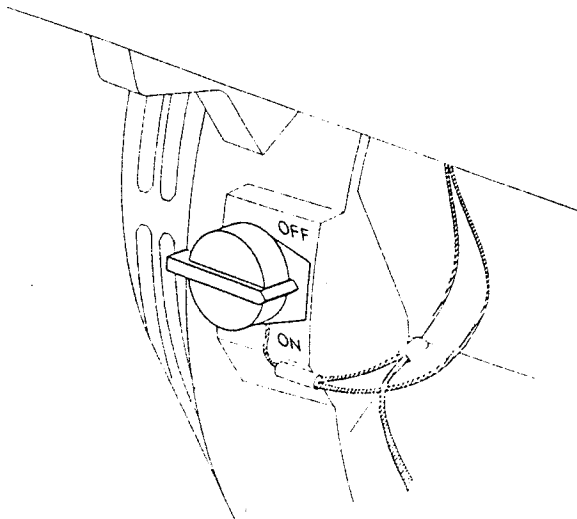

SAFETY INTERLOC WIRING DIAGRAM

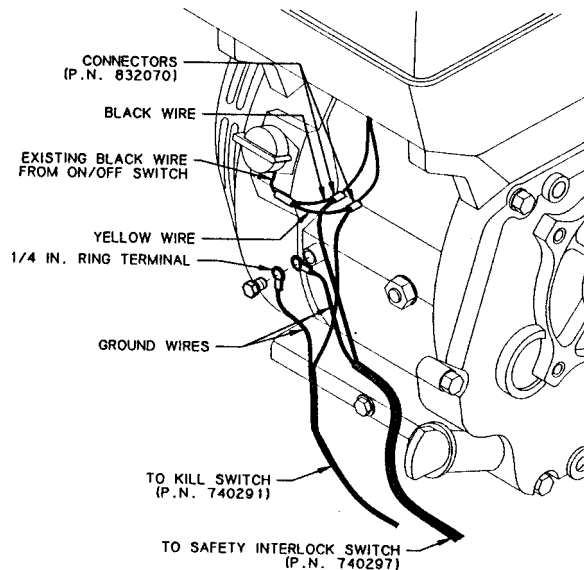

KOHLER 8.5 HP

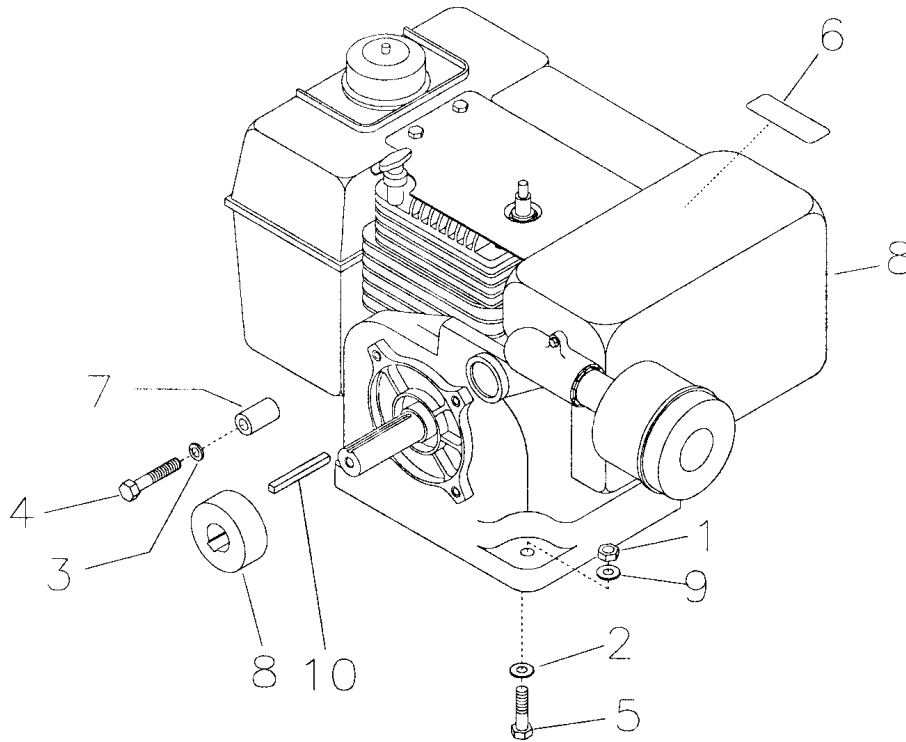

PARTS LIST

Item	Part No.	Qty.	Description
1	711380	4	3/8-16 Nyloc Nut
2	711508	4	.44 x 1.00 x .06 Flat WSR
3	711546	4	WSR-Helical 1/4
4	713045	4	BLT-HH 3/8-16 x 2.25 #5
5	713046	4	BLT-HH 3/8-16 x 2.00 #5
6	715314	1	Muffler Decal
7	350150	4	Spacer, .406 x .75 x 1.38
8	350603	1	Engine 8.5 HP Kohler
9	711515	4	WSR-Flat .44 x .87 x .07
10	74-112-A	1	Key, 1/4 x 1/4 x 2 1/2
11	81-61-A	1	Engine Pulley

SAFETY INTERLOC WIRING DIAGRAM KOHLER 8.5 HP

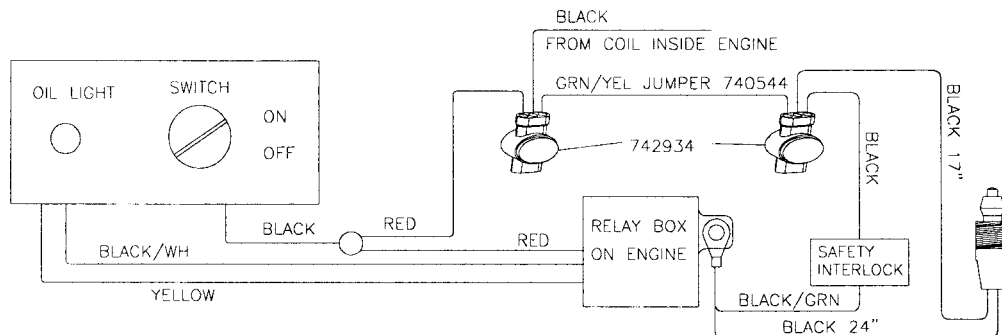

BRIGGS & STRATTON 8 HP

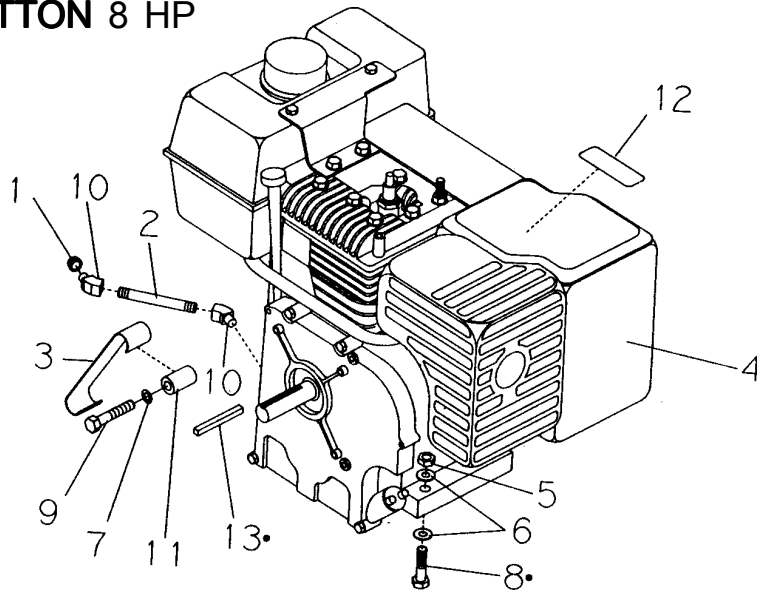

PARTS LIST

Item	Part No.	Qty.	Description
1	340698	1	3/8 Brass Cap
2	350107	1	Brass Pipe 3/8 NPT x 4.0
3	350112	2	Finger Guard
4	350600	1	8 HP Briggs & Stratton IP Engine
5	711374	4	5/16-18 Nyloc Nut
6	711506	8	5/16 Flatwasher
7	711546	4	3/8 Helical Washer
8	713031	4	5/16-18 x 2 Hex Bolt (Grd. 5)
9	713047	4	3/8-16 x 2.25 Hex Bolt (Grd. 5)
10	73-234-A	2	3/8 NPT Brass Street 45
11	82-151-A	4	.406 x .75 x 1.5 Spacer
12	715314	1	Muffler Decal
13	74-112-A	1	1/4 x 1/4 x 2 1/2 Key
	350120	1	Engine Pulley
	350186	1	Rope Guide

SAFETY INTERLOC WIRING DIAGRAM BRIGGS & STRATTON

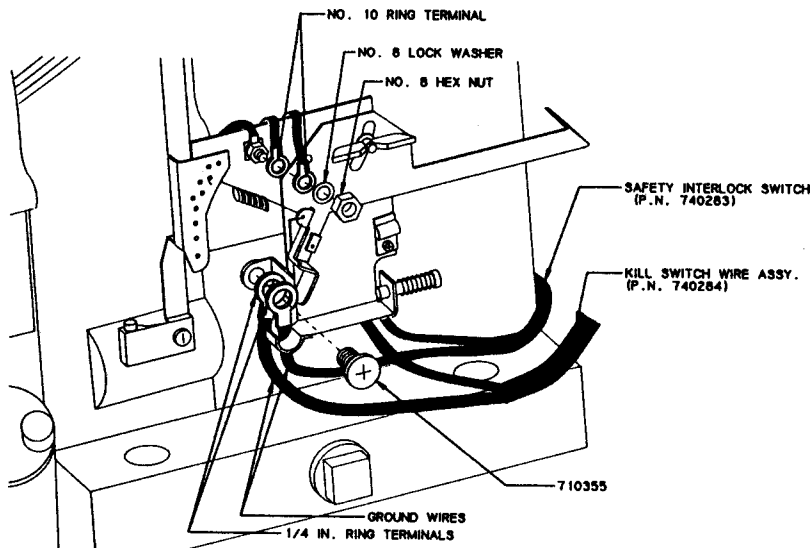

TRACTION/FRAME ASSEMBLY

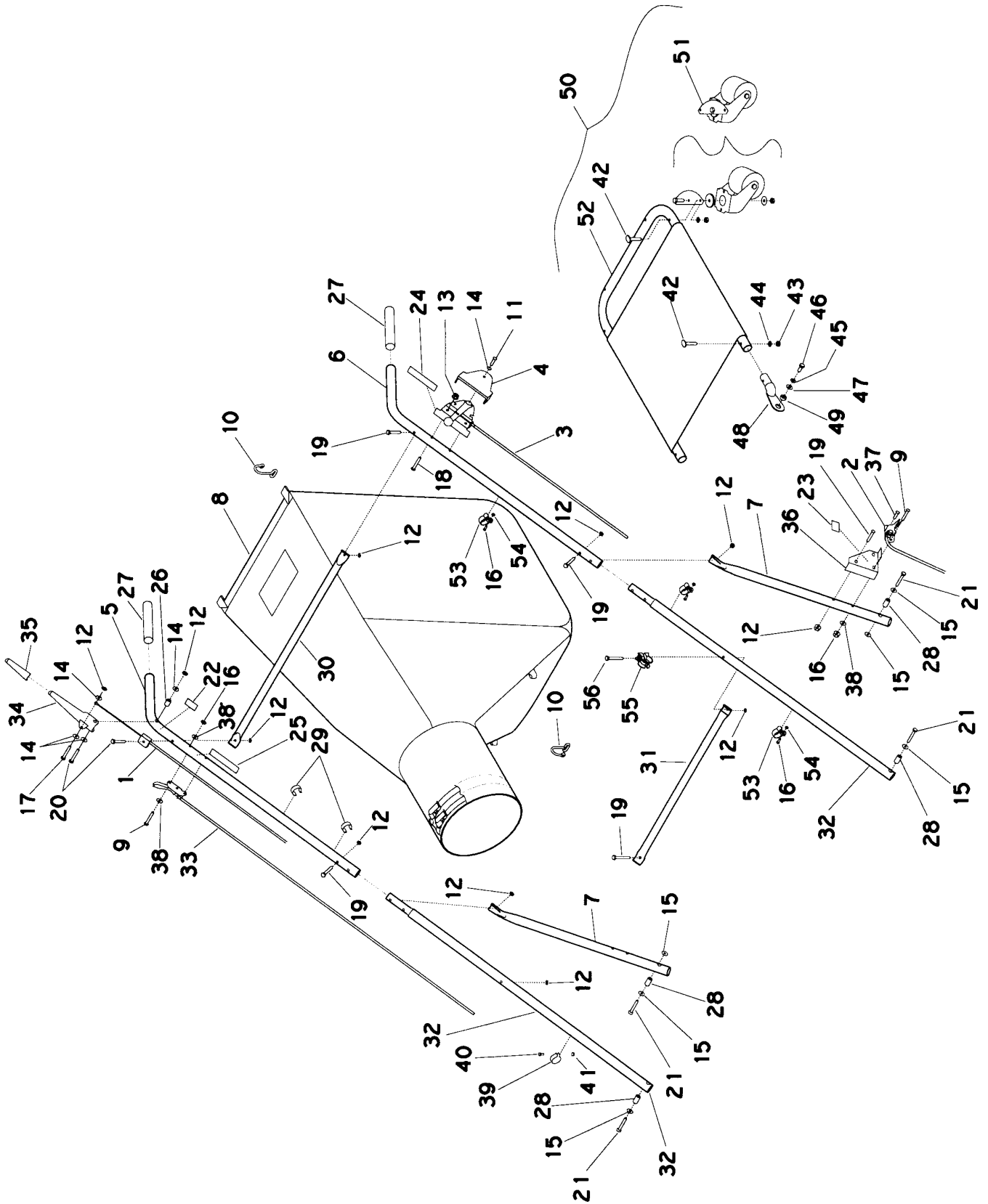

PARTS LIST

Item	Part No.	Qty.	Description	Item	Part No.	Qty.	Description
1	350124	1	Clutch Cable Assembly	29	80-276-A	3	Snap Mount
2	350125	1	Brake Cable Assembly	30	81-04-B	1	Crossbar Upper
3	350126	1	Transmission Shifter Cab	31	81-58-B	1	Crossbar Brace
4	350143	1	Plastic Cover Shifter	32	82-242-B	2	Middle Handle
5	350144	1	Upper Handle Right	33	83-25-B-54	1	Throttle Control Assembly
6	350145	1	Upper Handle Left	34	83-30-B	1	Clutch Grip Machined
7	350147	2	Support Brace Lower	35	83-31-B	1	Grip Clutch Handle
8	350800	1	Bag Assembly	36	350114	1	Brake Cable Mounting Bracket
9	515-10-24	3	SCR-RD HD 10/24 x 1 1/2	37	712811	1	SCR-MC 10-24 x .50 STPL
10	63-304-A	4	Bag Hook	38	711503	5	WSR-Flat #10
11	710178	1	SCR-MC 1/4-20 x .50 STPL	39	86-59-B	1	Clamp 1/32 x 3/8 x 4 1/1
12	711373	11	Nut- Nyloc 1/4-20	40	710130	1	SCR-MC 8-32 x .62 ST NI
13	711377	2	Nut-Lock 1/4-20	41	711372	1	Nut-Nyloc 8-32
14	711505	5	WSR-Flat 1/4	42	69-416-24	6	BLT-CONT HD 1/4-20 x 1.5
15	711506	6	WSR-Flat 5/16 STPL	43	711316	6	Nut-Hex 1/4-20 ST PL
16	712638	7	Nut-Hex 10/24 SS Nyloc	44	711544	6	WSR-Helical 1/4
17	713003	1	BLT-HH 1/4-20 x 1 #5	45	711545	2	WSR-Helical 5/16
18	713004	2	BLT-HH 1/4 -20 x 1 1/4 #5	46	713027	2	BLT-HH 5/16-18 x 1 #5
19	713005	8	BLT-HH 1/4-20 x 1 1/2 #5	47	76-36-A	2	WSR-Special
20	713007	2	BLT-HH 1/4-20 x 2 #5	48	81-116-A	2	Tubing End Cap
21	713029	4	BLT-HH 5/16-18 x 1 1/2 #5	49	81-120-A	2	Spacer
22	715302	1	Decal Clutch Engage	50	MA-471-D	1	Bag Platform
23	715308	1	Decal Parking Brake	51	SA-1021-B	1	Caster and Plate Assembly
24	715309	1	Decal Shift Position	52	SA-1023-C	1	Frame and Platform Assembly
25	715316	1	Decal Throttle Control	53	350174	1	Clamp
26	80-225-A	2	Spacer	54	712811	3	SCR-MC 10-24 x .50 STDL
27	80-232-A	2	Handle Grip, Red	55	350186	1	Rope Guide
28	80-238-A	4	Insert Bushing Handle	56	713008	1	Bolt-HH 1/4-20 x 2 1/4 #5

TRACTION /FRAME ASSEMBLY

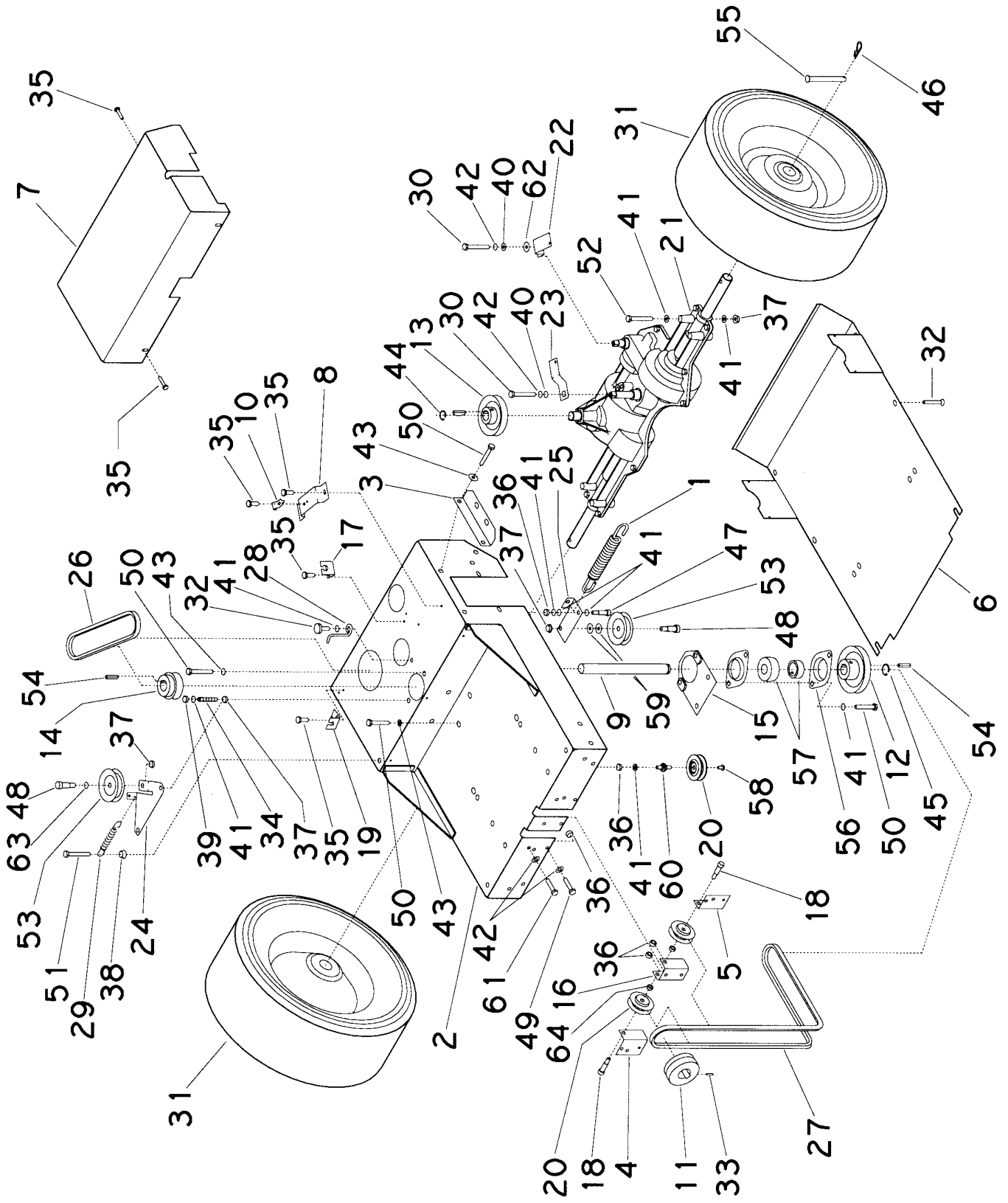

PARTS LIST

Item	Part No.	Qty.	Description	Item	Part No.	Qty.	Description
1	210035	1	Return Spring	33	711016	1	SCR-SK 1/4-20 x .50
2	350100	1	Main Frame	34	711047	1	SCR-SK 5/16-18 x 1.50
3	350106	2	Transmission Mounting Bracket	35	711124	12	SCR-ST-B 10 x .37 NI
4	350108	1	Bracket Pulley LH	36	711373	6	Nut-Nyloc 1/4-20
5	350109	1	Bracket Pulley RH	37	711374	7	Nut-Nyloc 5/16-18
6	350110	1	Cover Base	38	711379	1	Nut-Flanged Wizz 5/16-18
7	350111	1	Clutch Cover Top	39	711383	1	Nut-Hex Center Loc 5/16-18
8	350113	1	Cable Mounting Bracket	40	711505	3	WSR-Flat 1/4
9	350115	1	Drive Shaft 3/4	41	711506	15	WSR-Flat 5/16 STPL
10	350119	1	Conduit Clip	42	711544	8	WSR-Helical 1/4
11	350120	1	Pulley Motor	43	711545	7	WSR-Helical 5/16
12	350121	1	Pulley 3.5 x 3/4	44	711714	1	Retaining Ring - Ext .62
13	350122	1	Pulley 3" x 5/8 Bore	45	711715	1	Retaining Ring - Ext .75
14	350123	1	Pulley 2" x 3/4 Ax20x3/4	46	711808	2	Cotter Pin- Hair #13
15	350133	1	Bearing Bracket	47	712041	1	BLT-SDER 1/4-20 x .44 x .37
16	350134	1	Pulley Bracket Center	48	712081	2	BLT-SDR 5/16-18 x .75 x .375
17	350142	1	Mounting Bracket Shifter	49	713000	4	BLT-HH 1/4-20 x 1/2 #5
18	350146	2	Shoulder Screw	50	713027	9	BLT-HH 5/16-18 x 1 #5
19	350151	1	Clutch Cable Mounting Bracket	51	713033	1	BLT-HH 5/16-18 x 2 1/2 #5
20	350166	3	Idle Pulley Assembly	52	713034	4	BLT-HH 5/16-18 x 2 3/4 #5
21	350300	1	Transmission w/Brake	53	76-456-A	2	Pulley
22	350301	1	Brake Lever	54	762375	2	Key, .187 x 3/4
23	350302	1	Transmission Shift Lever	55	80-44-A	2	Clevis Pin
24	350303	1	Idle Pulley Bracket Clutch	56	340742	4	Bearing Flange
25	350304	1	Tensioner Engine Drive	57	881059	2	Bearing
26	350305	1	Belt Goodyear 3L200	58	712540	1	SCR-MC 10-24 x .37 SS
27	350306	1	Belt Goodyear 3L520	59	711523	2	Wave Washer
28	350307	1	Belt Popper	60	350187	1	Pulley Stud
29	350308	1	Clutch Return Spring	61	713002	2	BLT-HH 1/4-20 x 3/4
30	60-416-10	2	BLT-H 1/4-28 x 5/8 #5	62	711592	1	WSR-Plastic
31	68-310-B	2	Wheel Assembly	63	711507	1	WSR-Flat
32	72-416-10	9	BLT-ST 1/4-20 X 5/8	64	82-135-A	2	Spacer

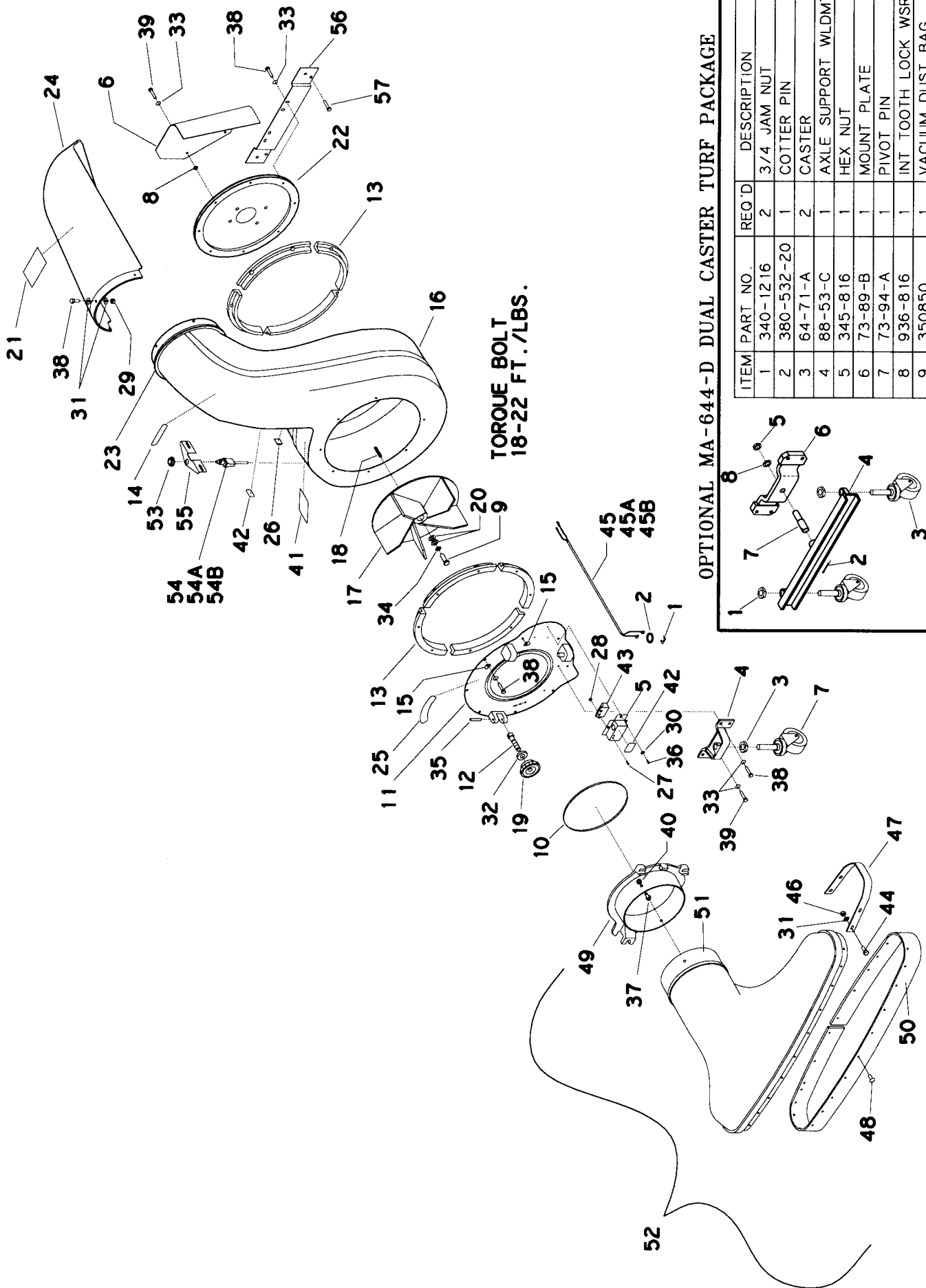

TORQUE BOLT
18-22 FT./LBS.

OPTIONAL MA-644-D DUAL CASTER TURF PACKAGE

ITEM	PART NO.	REQ'D	DESCRIPTION
1	340-12-16	2	3/4 JAM NUT
2	380-532-20	1	COTTER PIN
3	64-71-A	2	CASTER
4	88-53-C	1	AXLE SUPPORT WLDMT
5	345-816	1	HEX NUT
6	73-89-B	1	MOUNT PLATE
7	73-94-A	1	PIVOT PIN
8	936-816	1	INT TOOTH LOCK WSR
9	350850	1	VACUUM DUST BAG

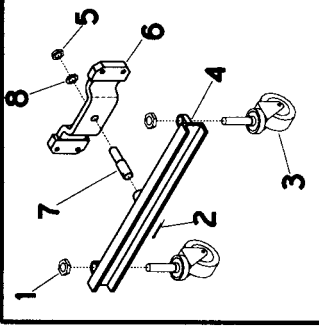

PARTS LIST

Item	Part No.	Qty.	Description	Item	Part No.	Qty.	Description
1	100028	1	Strain Relief	32	711509	1	1/2 Flatwasher
2	101008	1	Rubber Grommet	33	711544	18	1/4 Lockwasher
3	340-1216	1	Hex Jam Nut	34	350242	1	Belleville Washer
4	66-430-C	1	Caster Bracket	35	711661	1	Spring Pin
5	350130	1	Switch Bracket	36	712810	3	10-24 x .62 MCH Screw
6	350132	1	Heat Shield	37	713001	4	1/4-20 x .63 Hex Bolt
7	64-71-A	1	Stem Type Caster	38	713003	14	1/4-20 x 1.00 Hex Bolt
8	54-227-A	2	Spacer	39	713004	4	1/4-20 x 1.25 Hex Bolt
9	60-716-20	1	7/16-20 x 1.25 Hex Bolt (Grd. 5)	40	369-416	4	1/4-20 Serrated Hex Lock Nut
10	63-190-A	1	O-Ring Gasket	41	715300	1	Warning Decal
11	63-191-D	1	Front Plate	42	715313	2	Safety Interlock Decal
12	63-192-A	1	Pivot Bolt	43	740282	1	Gray Safety Switch
13	64-78-C	8	Anti-Wrap Segment	44	713002	8	1/4-20 x .75 Hex Bolt
14	67-08-A	1	Spin Pak Decal	45	740284	1	Wire Lead (Briggs)
15	78-120-A	2	Cable Clip	45A	740288	1	Wire Lead (Kohler)
16	70-103-F	1	Housing Assembly	45B	740291	1	Wire Lead (Honda)
17	72-175-D	1	Fan Wheel, 8 HP	46	711377	8	1/4-20 Lock Nut
18	74-112-A	1	1/4 x 2.50 Fan Key	47	62-98-C	2	Guard
19	80-29-A	1	Adjusting Knob	48	80-332-A	15	Xmas Tree Fastener
20	82-138-B-32	1	7/16 Flatwasher	49	63-195-D	1	Collar
21	715318	1	Caution Decal	50	73-76-C	1	Skirt (24" intake)
22	84-372-C	1	Back Plate and Gasket	50A	73-67-D	1	Skirt (30" intake)
23	85-59-C	1	Retaining Ring	50B	73-74-D	1	Skirt (36" intake)
24	85-61-D	1	Spin-Pak® Deflector	51	65-567-F	1	24" Intake Housing
25	85-151-A	1	Warning Decal	51A	77-18-F	1	30" Intake Housing
26	809443	1	Cord Clip	51B	MA-121	1	36" Intake Housing
27	710130	2	8-32 x .62 MCH Screw	52	MA-113-D	1	24" Intake
28	711372	2	8-32 Nyloc Nut	52A	MA-251-D	1	30" Intake
29	711373	4	1/4-20 Nyloc Nut	52B	MA-120-D	1	36" Intake
30	711503	3	#10 Washer	53	350135	1	Switch Nut
31	711505	16	1/4 Flatwasher	54	740283	1	Safety Switch (Briggs)

LIMITED WARRANTY

Minuteman International, Inc. warrants to the original purchaser/user that this product is free from defects in workmanship and materials under normal use and service for a period of two years from date of purchase. In addition, Minuteman International, Inc. will, at its option, honor labor warranty claims for the first 12 months from date of sale, provided such claims are submitted through and approved by factory authorized repair stations. Minuteman International, Inc. will, at its option, repair or replace without charge, except for transportation costs, parts that fail under normal use and service when operated and maintained in accordance with the applicable operation and instruction manuals.

This warranty does not apply to normal wear, or to items whose life is dependent on their use and care, such as belts, cords, switches, hoses, rubber parts, electrical motor components or adjustments. Parts not manufactured by Minuteman International, Inc. such as engines, batteries, battery chargers, hydraulic pumps, and tires are covered by and subject to the warranties and/or guarantees of their manufacturers. Please contact Minuteman International, Inc. for procedures in warranty claims against these manufacturers.

Special warning to purchaser — Use of replacement filters and/or prefilters not manufactured by Minuteman International, Inc. or its designated licensees, will void all warranties expressed or implied.

A potential health hazard exists without exact original equipment replacement.

All warranted items become the sole property of Minuteman International, Inc. or its original manufacturer, whichever the case may be.

Minuteman International, Inc. disclaims any implied warranty, including the warranty of merchantability and the warranty of fitness for a particular purpose. Minuteman International, Inc. assumes no responsibility for any special, incidental or consequential damages.

This limited warranty is applicable only in the U.S.A. and Canada, and is extended only to the original user/purchaser of this product. Customers outside the U.S.A. and Canada should contact their local distributor for export warranty policies. Minuteman International, Inc. is not responsible for costs or repairs performed by persons other than those specifically authorized by Minuteman International, Inc. This warranty does not apply to damage from transportation, alterations by unauthorized persons, misuse or abuse of the equipment, use of non-compatible chemicals, or damage to property, or loss of income due to malfunctions of the product.

If a difficulty develops with this machine, you should contact the dealer from whom it was purchased.

This warranty gives you specific legal rights, and you may have other rights which vary from state to state. Some states do not allow the exclusion or limitation of special, incidental or consequential damages, or limitations on how long an implied warranty lasts, so the above exclusions and limitations may not apply to you.

Minuteman[®]
Parker[®]

A Member of the Hako Group of Companies

World Headquarters

Minuteman International, Inc.
111 South Rohlwing Road
Addison, Illinois 60101

Phone 630-627-6900

Fax 630-627-1130

www.minutemanintl.com

Minuteman Canada, Inc.

2210 Drew Road
Mississauga, Ontario
L5S 1B1

Phone 905-673-3222

Fax 905-673-5161

988200

Printed in U.S.A.