

OWNER'S GUIDE

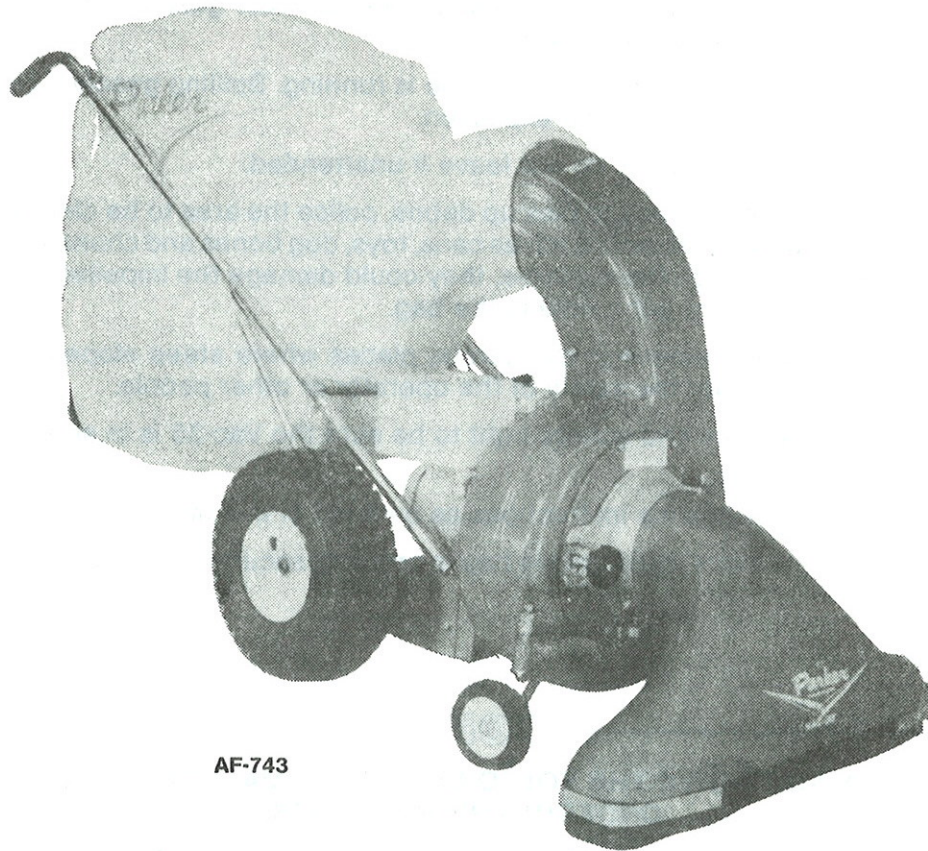

VACUUM SWEEPER VAC-35 GASOLINE ENGINE MODEL NO. PV-8805-I/C



AF-743

**READ THESE INSTRUCTIONS
BEFORE SETTING UP AND OPERATING MACHINE**

**BE SAFE. PROTECT YOUR FAMILY, YOUR FRIENDS, YOURSELF.
OBSERVE ALL SAFETY INSTRUCTIONS.**

PARKER SWEEPER COMPANY

Box 1728

Springfield, Ohio 45501

Plate No. 1241

87-35-A

TO THE OWNER

These instructions were written to assist you in the assembly and operation of your Vac-35. **READ THE INSTRUCTIONS** thoroughly **BEFORE** attempting to assemble and operate the machine so that you are familiar with the complete procedure and the safety precautions.

RULES FOR SAFE OPERATION



The following safety precautions are suggested to prevent damage to the equipment or injury to the operator or nearby persons.

1. Do not allow anyone to operate the Vac-35 without proper instructions.
2. Do not permit children to operate the Vac-35.
3. Do not sweep too close to fire. Ingesting hot ashes will ignite the bag.
4. Stop the engine before reaching into the intake nozzle or discharge chute to dislodge sticks or other debris.
5. Stop the engine before attempting to make any adjustment or performing any maintenance work on the Vac-35.
6. When working on the engine, always remove the spark plug wire from the engine and attach it to the V shaped clip on the engine head.
7. Do not run the engine in an enclosed area. Exhaust gases contain carbon monoxide, an odorless and deadly poison.
8. Do not fill the fuel tank while the engine is running. Spilling gasoline on a hot engine may cause a fire or an explosion.
9. While machine is running, do not leave it unattended.
10. Before using the machine to pick up debris, police the area to be cleaned first, picking up any large objects such as cans, toys, dog bones and chunks of wood. If these pass through the machine, they could damage the impeller, bend the engine crankshaft or put a hole in the bag.
11. Avoid using the machine in dangerous places where steep slopes or loose debris will endanger the safety of the operator or other people.
12. Keep all nuts, bolts and screws tight to be sure the Vac-35 is in safe working condition.
13. Follow the maintenance instructions as outlined in this manual.
14. Do not start or run engine unless bag is properly secured as injury may result.

IMPORTANT

ALWAYS GIVE THE FOLLOWING INFORMATION WHEN ORDERING REPAIR PARTS:

- | | |
|-------------------------------|------------------------|
| 1. Part Number (Not Ref. No.) | 3. Description of Part |
| 2. Quantity Needed | 4. Model No. of Vac-35 |

If unable to obtain parts locally, write down above information and send to:
PARKER SWEEPER CO., BOX 1728, SPRINGFIELD, OHIO 45501

Your unit is right hand (R.H.) or left hand (L.H.) as you stand behind it.

ASSEMBLY INSTRUCTIONS

OBSERVE SAFETY RULES AT ALL TIMES. DON'T TAKE CHANCES!

UNPACKING

1. Remove all loose items from carton.
2. Use a hammer or nail puller to remove carton from wooden base.
3. Do not discard the carton or inserts until the unit is completely assembled.
4. Whenever the terms left or right hand, or "L" and "R", are used, it means from a position standing behind the unit facing forward. All hardware is on the unit in its proper location.

ASSEMBLING HANDLES

1. Place Back Braces behind unit, laying on floor.
2. Remove the Lock Nuts, Hex Hd. Bolts, and Flatwashers from ends of Middle Handle Assembly, leaving inserts in place.
3. Align lower holes in Middle Handle Assembly with the top holes in Handle Brackets. NOTE: The Middle Handle Assembly must be to the outside of Handle Brackets.
4. Replace hardware removed in step 2, as shown in AF-744. Do Not Tighten.
5. Remove the four Hex Hd. Bolts and Lock Nuts from lower ends of Upper Handle Assembly.
6. Place Upper Handle Assembly down over top ends of Middle Handle Assembly.
7. Align lower holes in both the Upper and Middle Handle Assemblies. Replace one Hex Hd. Bolt in each hole. Do Not reassemble Lock Nuts.
8. Lift Upper and Middle Handle Assemblies until Back Braces can be assembled to Hex Hd. Bolts. Assemble Lock Nuts. Do Not Tighten.
9. Align upper holes in Upper and Middle Handle Assemblies. Assemble Hex Hd. Bolts and Lock Nut. Tighten All Nuts.

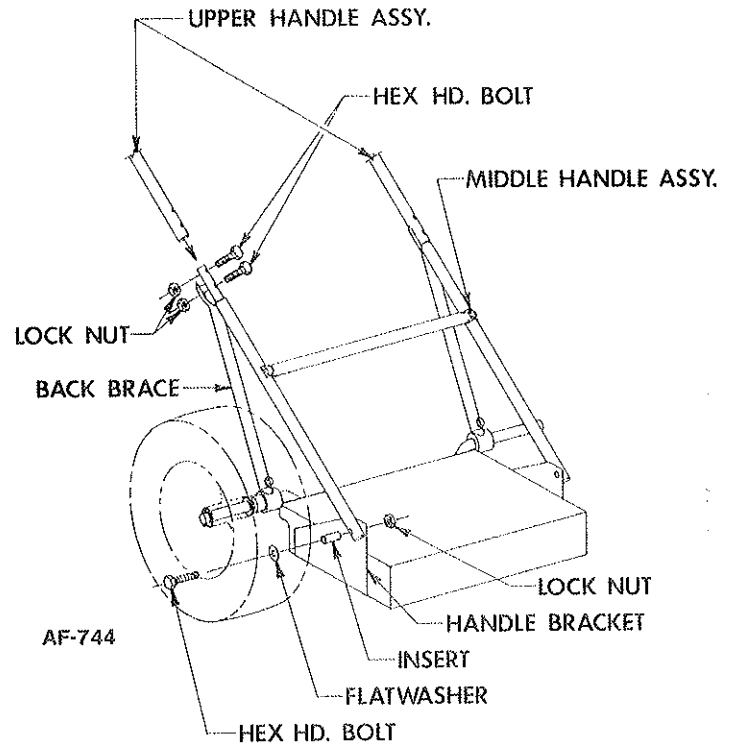

THROTTLE HOOKUP

1. To assemble Throttle Control, remove the Throttle Control from around the Engine and straighten the Throttle Cable behind the unit.
2. Remove the Snap-On Clamp from the Right Hand Middle Handle Assembly. Pull the bottom of the Throttle Cable to the Left Hand Back Brace and secure with Snap-On Clamp.
3. Remove the Rd. Hd. Screws and Lock Nuts from the Throttle Control, by the Lever, and continue to run Cable up the Left Hand Handle.

NOTE: The Throttle Control Lever must be on the outside of Handle.

4. Place the Rd. Hd. Screws through Handle from inside, attach Throttle Control Lever and secure with Lock Nuts.

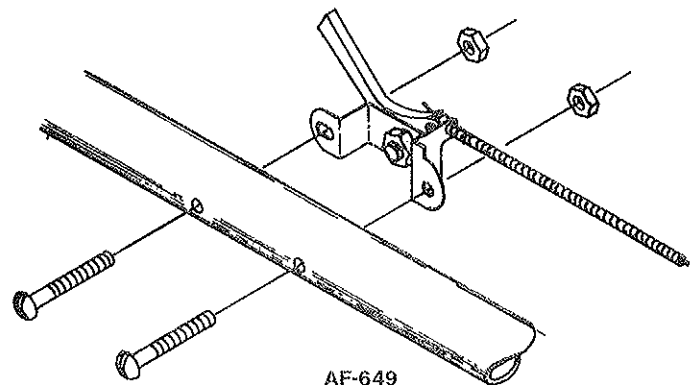

**SAFETY IS IMPORTANT! DO NOT IGNORE IT!
OBSERVE IT! BE SAFE**

ASSEMBLY INSTRUCTIONS (cont.)

NOTE FAILURE TO OBSERVE SAFETY INSTRUCTIONS MAY RESULT IN SERIOUS INJURY.

ATTACHING DEFLECTOR

1. Remove the hex hd. bolts, lock nuts, and flatwashers that hold the retaining ring to the neck of the blower housing. DO NOT remove retaining ring.
2. Align the holes in the Spin-Pak® with the three upper holes in the retaining ring and blower housing.
3. Replace hardware and tighten.

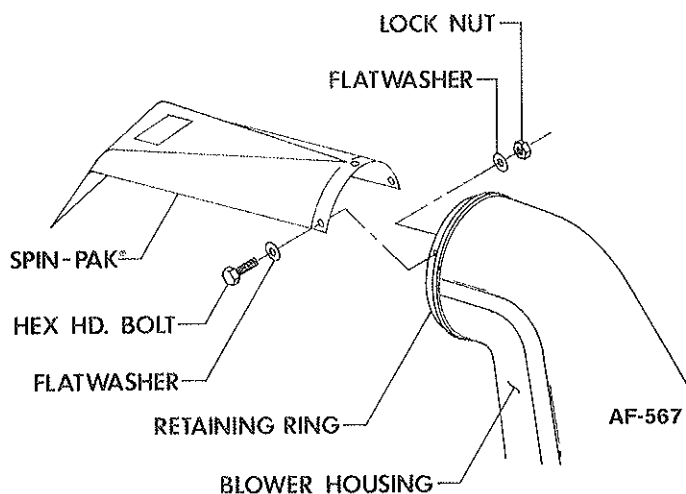

ATTACHING DUST BAG

1. Attach the dust bag to the unit by placing the bag hooks over the upper and lower crossbars.
2. Slip the neck of the dust bag over the Spin-Pak® until the tie strap can be pulled tight around the housing neck just over the bead on the retaining ring. The bead must be covered.

WARNING: Failure to attach the front bag hooks to the lower crossbar can cause premature wear of bag and neck at the Spin-Pak®. The Spin-Pak® may also break prematurely due to excessive weight from the bag.

ATTACHING INTAKE HOUSING

1. Insert the hinge bosses on collar of intake housing behind the hinge rod on front cover assembly.
2. Swing intake housing to lay flat against front cover assembly.
3. Secure by placing flatwasher and adjusting knob, on pivot bolt, over the collar of intake housing and tightening adjusting knob.

OPERATING INSTRUCTIONS

READ SAFETY & OPERATING INSTRUCTIONS BEFORE OPERATING EQUIPMENT

WARNING: The engine contains NO OIL. Read the Engine Instruction Manual carefully before operating the VAC-35. Be sure you know how to start and stop the engine before proceeding further. Do not start the engine until all assembly is finished.

Before starting the engine read and understand the following:

1. Be sure your engine crankcase is filled with the proper type and amount of oil.
2. Spin-Pak® is in place.
3. Dust Bag or Discharge Hose is in place.
4. Intake Housing or Hose Kit is attached to the Fan Housing.
5. Heavy concentration of sand and gravel should be avoided. These materials are extremely abrasive, and while the VAC-35 will handle moderate amounts of these materials, it is not designed for heavy applications. Because these materials are extremely heavy, only small amounts should be allowed to collect in the bag because large amounts cause poor handling and difficulty in pushing. The VAC-35 is capable of picking up empty tin cans and blocks of wood, but it was not intended for this type of service, since tremendous stresses build up as these pieces pass through the impeller. Treat your VAC-35 with reasonable care and it will repay you with long trouble-free service.

6. The VAC-35 will handle most common kinds of debris found around industrial plants, commercial buildings, homes and farms. Acid contaminated materials, magnesium, dust and other DANGEROUS DEBRIS that is considered hazardous should not be handled with the VAC-35 unless approved by a regulating authority considered to be an expert in the handling of such hazardous materials.

DANGER: Improper use of this equipment may result in serious injury.

TO STOP ENGINE

The stop switch for the Briggs & Stratton engine on this unit is operated by the throttle control lever. To stop engine, back off on the throttle as far as possible; this works as an automatic stop switch on the engine.

WARNING: Allow engine to cool 2 or 3 minutes before refueling. Fuel spilled on a hot engine could ignite, resulting in serious damage to the unit and possible injury to the operator.

IMPORTANT INFORMATION

The VAC-35 is not equipped with a spark arrestor muffler. If the VAC-35 is to be used in the state of California, the state law requires spark arrestor mufflers be used to comply with Section 4442 of the California Public Resources Code. Contact your service center and have this muffler installed.

MAINTENANCE INSTRUCTIONS

DUST BAG CARE

1. To clean the dust bag, turn the bag inside out and reattach to the unit.
2. Start the engine and run at full throttle. Lightly tap the bag to release the dust trapped in the weave.
3. When the bag is clean, remove it and turn it right side out again. Reattach to the unit and resume sweeping.

The efficiency of the unit depends on the breathing capacity of the dust bag. Under extremely dusty conditions the bag should be emptied and cleaned frequently. Always empty and clean bag before storing after use. Debris allowed to remain in the bag may cause spontaneous combustion, resulting in an explosion or fire.

OPTIONAL ACCESSORIES

NOTE: Accessory No. and Price List can be obtained from a local distributor.

Discharge Hose Kit: Attaches to exhaust port for leading debris into truck, container, etc.

Hose Attachment 6" Dia.: 15 ft. length overall, fits all VAC-35 models. Attaches to impeller housing for cleaning debris from hard-to-reach areas.

Hose Attachment 4" Dia.: 15 ft. length overall, fits all VAC-35 models. Attaches to impeller housing for cleaning debris from hard-to-reach areas.

LUBRICATION

1. The wheels on the VAC-35 should be checked periodically to assure proper lubrication is maintained. Grease fittings are located on the hubs of the rear wheels when lubrication is needed. The smaller front wheels should be removed, any grass or dirt cleaned from axle or hole through hub. Apply a light coat of grease on axles before replacing wheels.
2. A few drops of light oil on the throttle control, lever and cable, will keep it operating smoothly.
3. Refer to engine operating manual for proper lubrication of the engine.
4. Add oil to the turf wheel assembly at the center where mounted to housing and ends where wheel axles are assembled.

Lumite® Bag: 10 cu. ft. capacity, polypropylene material. Won't fade, shrink, mildew or rot. Use when gathering damp or wet material.

Flip-Gate 30" Nose Cone: Allows convenient and adjustable intake of larger debris and trash.

24" Intake Housing: For sweeping in narrow aisles or in areas where heavier objects are to be collected.

36" Intake Housing: Ideal for sweeping lighter weight debris and in larger, open areas.

WARRANTY INFORMATION

Parker Sweeper Company warrants each new piece of equipment manufactured under its name except the engine, to be free of defects in materials and workmanship under normal use and service. Parker Sweeper Company's obligation is limited to repair or replacement at its option for one (1) year (ninety (90) days for commercial service) from date of purchase.

If trouble should occur with the engine, please contact the manufacturer, giving them all information: Name of Unit, purchased from company, (Power Vac 8805-1/C, Parker Sweeper Co., etc.); problem with engine, model number of engine, etc.; when unit was purchased; and a complete return address with zip code. Failure to provide complete information will result in unnecessary delay of repair and return of unit.

ENGINE:

Briggs & Stratton Company
P.O. Box 702
Milwaukee, Wisconsin 53201

Proper assembly of replacement parts is the responsibility of the owner or mechanic doing the work. Parker Sweeper Company warranty only applies to the original purchased unit and/or replacement parts if assembled correctly by a qualified mechanic. Under no circumstances does the warranty extend beyond the original time specified from date of purchase.

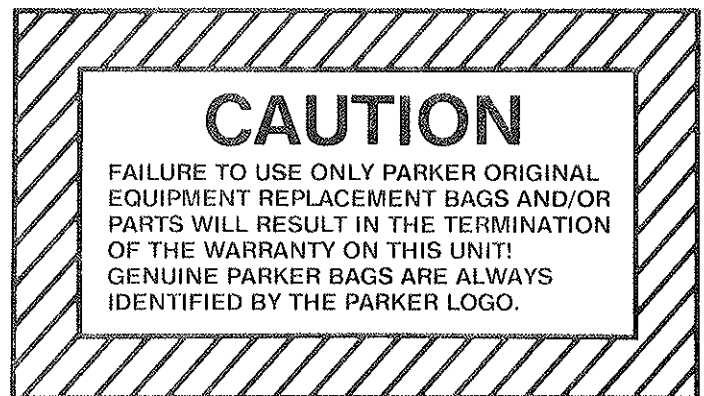

OBSERVE SAFETY RULES AT ALL TIMES. DON'T TAKE CHANCES!

HANDLE ASSEMBLY

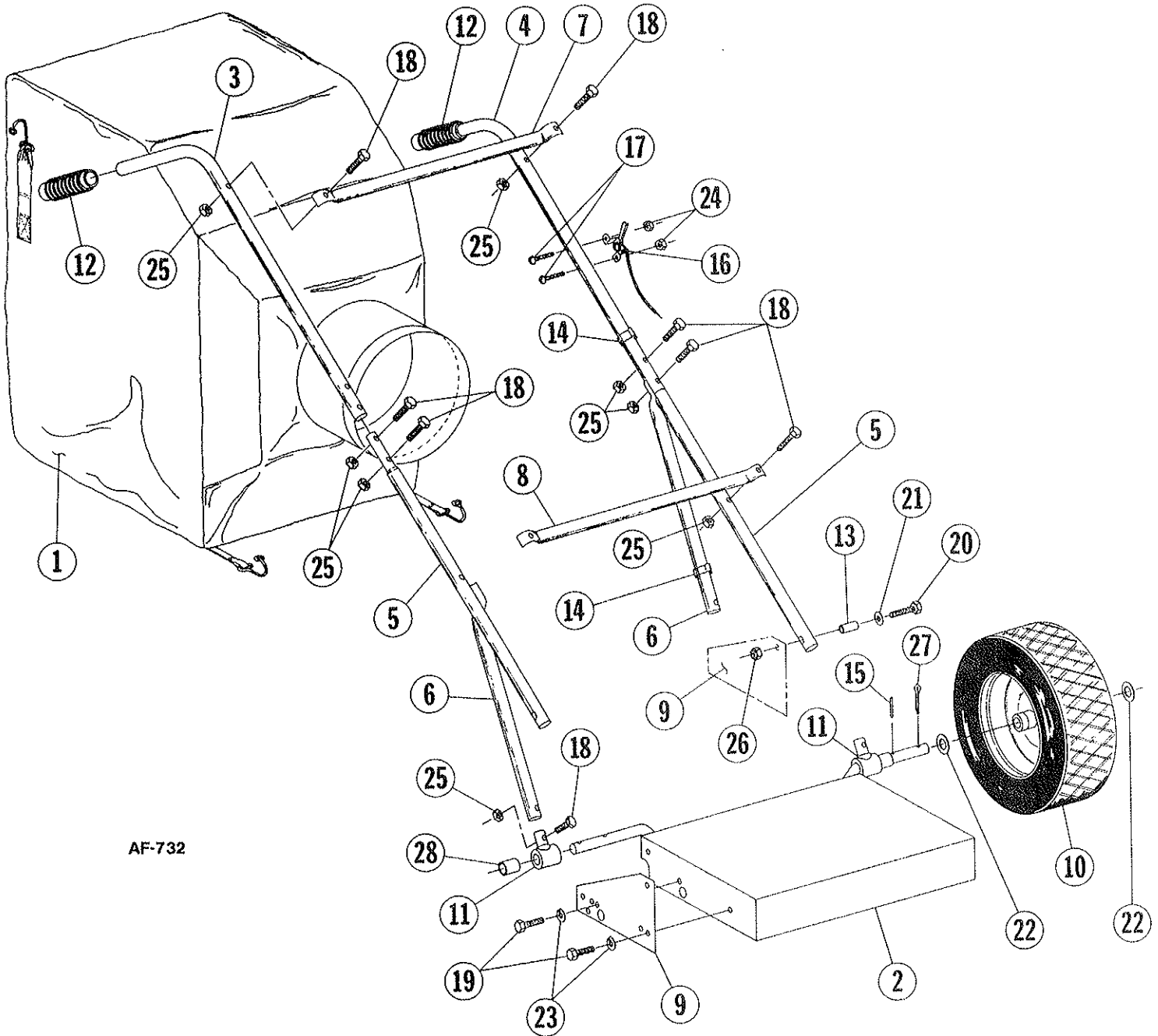

AF-732

HANDLE ASSEMBLY

PARTS LIST

Ref. No.	Part No.	Qty. Per Unit	Description
1	MA-585	1	Dust Bag
2	83-138-C	1	Chassis Weldment
3	80-321-C	1	Upper Handle, R.H.
4	83-18-C	1	Upper Handle, L.H.
5	82-245-B	2	Middle Handle
6	85-45-C	2	Handle Back Brace
7	81-04-B	1	Cross Bar, Upper
8	81-58-B	1	Cross Bar, Lower
9	73-362-C	2	Handle Bracket
10	SA-231-B	2	Wheel Assembly
11	85-44-B	2	Handle Back Brace Adaptor
12	80-232-A	2	Handle Grip
13	80-238-A	2	Insert
14	80-276-A	2	Clamp, Snap-On
15	84-103-A	2	Roll Pin .199-.194 Dia. x 1 1/2
16	83-25-B-44	1	Throttle Control Assembly
17	515-10-24	2	Screw, Rd. Hd. Mach. 10-24 x 1 1/2
18	65-416-24	10	Bolt, Hex Hd. 1/4-20 x 1 1/2
19	65-516-12	4	Bolt, Hex Hd. 5/16-18 x 3/4
20	65-516-24	2	Bolt, Hex Hd. 5/16-18 x 1 1/2
21	945-516	2	Flatwasher, Plain 5/16
22	945-1216	4	Flatwasher, Plain 3/4
23	935-516	4	Lockwasher, Spring 5/16
24	365-10	2	Nut, Hex Lock 10-24
25	365-416	10	Nut, Hex Lock 1/4-20
26	364-516	2	Nut, Hex Lock (thin) 5/16-18
27	380-432-20	2	Cotter Pin 1/8 x 1 1/4
28	85-89-A	2	Spacer

HOUSING ASSEMBLY

PARTS LIST

Ref. No.	Part No.	Qty. Per Unit	Description
1	70-103-D	1	Housing Assembly
2	85-110-B	1	Spin Pak®
3	64-78-C	8	Anti-Wrap Segment
4	84-239-C	1	Back Plate
5	81-194-D	1	Heat Shield
6	61-14-D	1	Fan Wheel
7	SA-1389-D	1	Front Cover Assembly
* 8	80-29-A	1	• Adjusting Knob
* 9	945-816	1	• Flatwasher, Plain 1/2
*10	63-190-A	1	• O-Ring Gasket
11	73-89-B	1	Mount Plate
12	73-94-A	1	Pivot Pin
13	83-211-B	1	Axle Support Weldment
14	82-138-B-1	1	Washer, Special
15	86-108-B	2	Axle Weldment
16	84-300-C	2	Wheel
17	76-254-A	2	End Cap
18	79-16-A	6	Spacer
19	81-106-A	2	Cotter Pin
20	SA-647-D	1	30" Intake Housing Assembly
**21	63-195-D	1	• Collar
**22	65-416-10	4	• Bolt, Hex Hd. 1/4-20 x 5/8
**23	369-416	4	• Nut, Serrated Hex Lock 1/4-20
24	73-67-D	1	Skirt
25	62-98-C	2	Guard
26	80-332-A	15	Fastener
27	65-416-12	8	Bolt, Hex Hd. 1/4-20 x 3/4
28	945-416	18	Flatwasher, Plain 1/4
29	364-416	8	Nut, Hex Lock (thin) 1/4-20
30	65-416-16	14	Bolt, Hex Hd. 1/4-20 x 1
31	65-416-20	4	Bolt, Hex Hd. 1/4-20 x 1 1/4
32	65-416-24	2	Bolt, Hex Hd. 1/4-20 x 1 1/2
***33	60-516-16	1	Bolt, Hex Hd. 5/16-24 x 1
34	945-816	4	Flatwasher, Plain 1/2
35	945-1216	1	Flatwasher, Plain 3/4
36	935-416	16	Lockwasher, Spring 1/4
37	935-516	1	Lockwasher, Spring 5/16
38	936-816	1	Lockwasher, Int. Tooth 1/2
39	345-816	1	Nut, Hex Jam 1/2-20
40	380-532-20	1	Cotter Pin 5/32 x 1 1/4
41	85-59-C	1	Retaining Ring
42	365-416	4	Flatwasher, Plain 1/4

*Items 8, 9, & 10 are supplied with item 7, but can be purchased separately.

**Items 21, 22 & 23 are supplied with item 20, but can be purchased separately.

***Item 33, Torque to 18-22 ft. lbs.

ENGINE ASSEMBLY

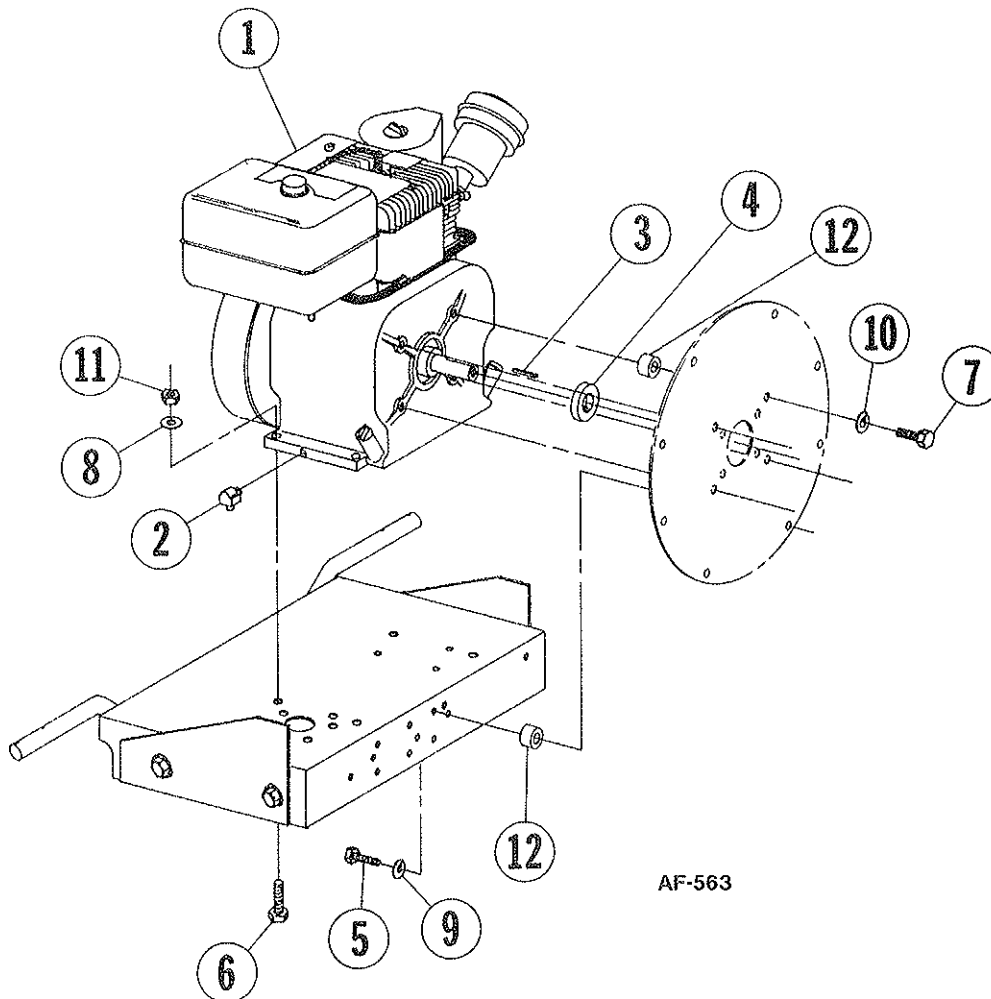

AF-563

PARTS LIST

Ref. No.	Part No.	Qty. Per Unit	Description
1	*	1	Engine, B&S I/C 5HP
2	61-25-A	1	Street Elbow 1/4 x 90°
3	61-65-A	1	Fan Key 3/16 sq. x 1 3/4 LG.
4	73-20-A	1	Fan Spacer
5	65-416-24	2	Bolt, Hex Hd. 1/4-20 x 1 1/2
6	65-516-24	4	Bolt, Hex Hd. 5/16-18 x 1 1/2
7	60-516-16	4	Bolt, Hex Hd. 5/16-24 x 1
8	945-516	4	Flatwasher, Plain 5/16
9	935-416	2	Lockwasher, Spring 1/4
10	935-516	4	Lockwasher, Spring 5/16
11	365-516	4	Nut, Hex Lock 5/16-18
12	81-24-A	6	Spacer

*B&S Model No. 132412 Spec. 0222-01