

OWNER'S GUIDE

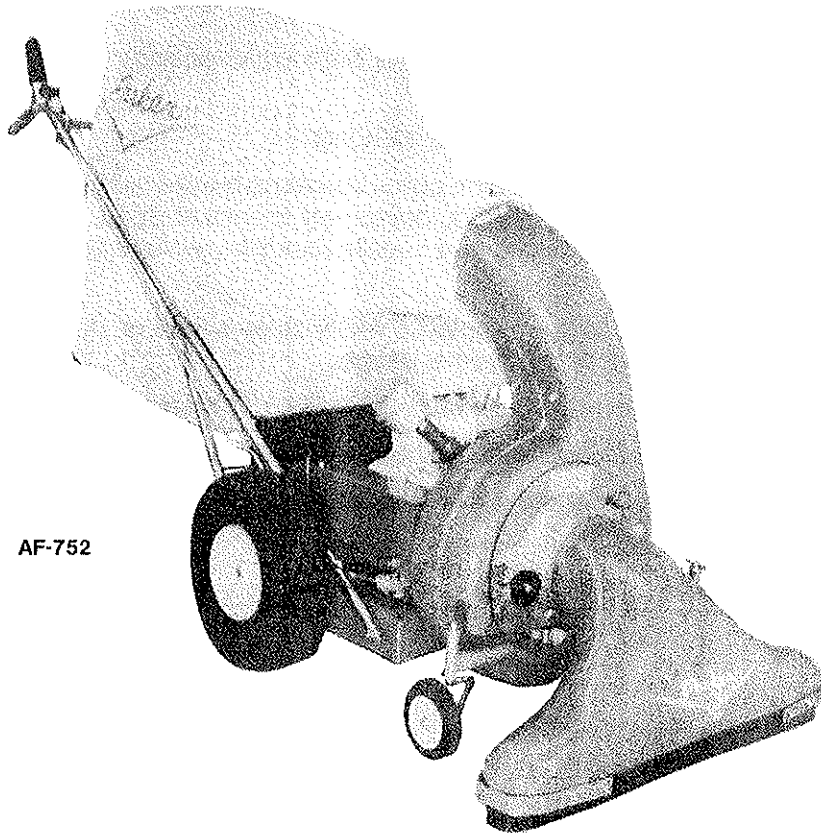

VACUUM SWEEPER VAC-35 GASOLINE ENGINE MODEL NO. PV-8708-K-SP



AF-752

**READ THESE INSTRUCTIONS
BEFORE SETTING UP AND OPERATING MACHINE**

**BE SAFE. PROTECT YOUR FAMILY, YOUR FRIENDS, YOURSELF.
OBSERVE ALL SAFETY INSTRUCTIONS.**

PARKER SWEEPER COMPANY

Box 1728

Springfield, Ohio 45501-1728

Plate No. 1274

87-198-A

TO THE OWNER

These instructions were written to assist you in the assembly and operation of your Vac-35. **READ THE INSTRUCTIONS** thoroughly **BEFORE** attempting to assemble and operate the machine so that you are familiar with the complete procedure and the safety precautions.

RULES FOR SAFE OPERATION



The following safety precautions are suggested to prevent damage to the equipment or injury to the operator or nearby persons.

1. Do not allow anyone to operate the Vac-35 without proper instructions.
2. Do not permit children to operate the Vac-35.
3. Do not sweep too close to fire. Ingesting hot ashes or cigarette butts will ignite the bag.
4. Stop the engine before reaching into the intake housing or discharge chute to dislodge sticks or other debris.
5. Stop the engine before attempting to make any adjustment or performing any maintenance work on the Vac-35.
6. When working on the engine, always remove the spark plug wire from the engine and attach it to the V shaped clip on the engine head.
7. Do not run the engine in an enclosed area. Exhaust gases contain carbon monoxide, an odorless and deadly poison.
8. Do not fill the fuel tank while the engine is running. Spilling gasoline on a hot engine may cause a fire or an explosion.
9. While machine is running, do not leave it unattended.
10. Before using the machine to pick up debris, police the area to be cleaned first, picking up any large objects such as glass, toys, dog bones and chunks of wood. If these pass through the machine, they could damage the impeller, bend the engine crankshaft or put a hole in the bag.
11. Avoid using the machine in dangerous places where steep slopes or loose debris will endanger the safety of the operator or other people.
12. Keep all nuts, bolts and screws tight to be sure the Vac-35 is in safe working condition.
13. Follow the maintenance instructions as outlined in this manual.
14. Do not start or run engine unless bag and intake Housing are properly secured as injury may result.

IMPORTANT

ALWAYS GIVE THE FOLLOWING INFORMATION WHEN ORDERING REPAIR PARTS:

- | | |
|--------------------------------------|-------------------------------|
| 1. Part Number (Not Ref. No.) | 3. Description of Part |
| 2. Quantity Needed | 4. Model No. of Vac-35 |

**If unable to obtain parts locally, write down above information and send to:
PARKER SWEEPER CO., BOX 1728, SPRINGFIELD, OHIO 45501**

Your unit is right hand (R.H.) or left hand (L.H.) as you stand behind it.

ASSEMBLY INSTRUCTIONS

YOUR SAFETY IS OUR CONCERN. READ ALL SAFETY RULES AND OPERATING INSTRUCTIONS BEFORE ATTEMPTING TO OPERATE THIS EQUIPMENT. FAILURE TO FOLLOW SAFETY RULES AND OPERATING INSTRUCTIONS MAY RESULT IN SERIOUS INJURY.

1. The VAC-35 covered in this owner's guide is shipped complete in one box. Follow all instructions on assembly very carefully.
2. Unpack Intake Housing, Spin-Pak®, Handle Assembly and Bag.
3. Tip box over so wheels are toward floor. Pull unit out of box and stand upright.
4. **DO NOT** discard the carton or any of the inserts until the unit is completely assembled.
5. All hardware is on the unit in its proper location. If something is missing, notify the dealer/distributor where unit was purchased. If unable to purchase parts locally, contact the Parker Sweeper Company.
6. Whenever the terms left or right hand, or "L" and "R" are used, it means from a position standing behind the unit facing forward.

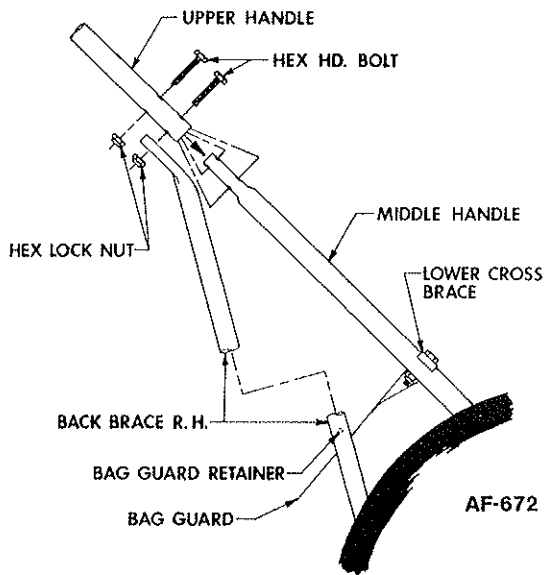

HANDLE ASSEMBLY

1. Remove the hex hd. bolts and hex lock nuts from the bottoms of the upper handle.
2. Place upper handle assembly over the ends of the middle handle assembly.
3. Align the lower holes in both the upper and middle handle assemblies. Replace a hex hd. bolt, removed in step 1, to each of the lower holes.
4. Remove bag guard retainer from the left hand back brace. Place one end of retainer into small hole on inside of left hand back brace.
5. Lift left hand brace until other end of retainer can be assembled into small hole on inside of right hand back brace.

6. Lift handle assembly until the back braces can be assembled to the bolts in the lower holes of the upper and middle handles. Lift the back braces at the same time, so the bag guard retainer does not become dislodged. Secure with hex lock nuts. **Do Not Tighten.**

NOTE: The bag guard retainer can not be assembled into back braces after they are assembled to upper handles. Bag guard should be laying against (transmission) back of chassis.

7. Align the upper holes in both the upper and middle handle assemblies. Assemble the remaining two hex hd. bolts and hex lock nuts. **Do Not Tighten.**
8. Check alignment of handle assembly. The hex lock nuts have been left loose to allow movement between the holes and the bolts. Do not bend tubing to accomplish proper alignment. Once handles are aligned tighten all hex lock nuts.
9. Nuts should be tightened enough that at least two of the bolt threads extend through the nut. It may be necessary to collapse the tubing **SLIGHTLY** to accomplish this.

THROTTLE HOOK-UP

1. Remove throttle control assembly from shipping position. Straighten cable and run up outer left hand side of handle assembly.
2. Remove the hex lock nuts and round head screws from throttle control assembly.
3. Align holes in stop switch and throttle control with those in upper left handle.
4. Reassemble round head screws, from inside of handle, and secure with hex lock nuts.
5. Secure throttle control cable to handle with snap-on clamps.

NOTE: Be sure not to place any bends in throttle control cable less than 8 inches radius.

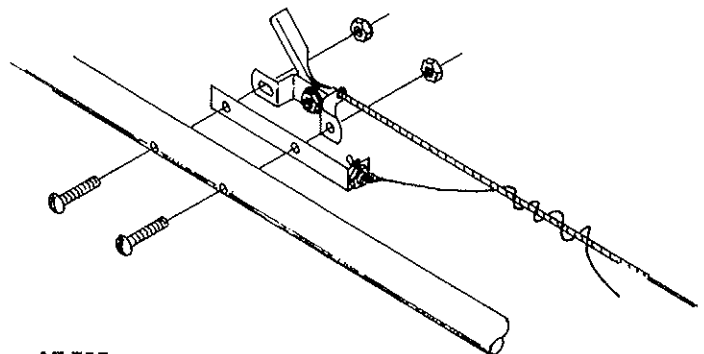

OBSERVE SAFETY RULES AT ALL TIMES. DON'T TAKE CHANCES!

ASSEMBLY INSTRUCTIONS

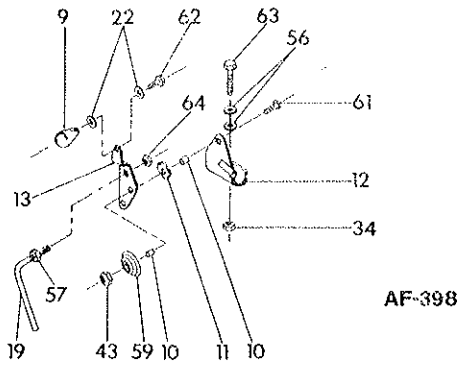

SHIFT LEVER CONNECTION

1. Loosen hex lock nut (34), securing bracket (12) to handle assembly, until bracket will slide freely on handle.
2. Remove hex lock nut (64) from shifter rod (19). Tighten plain nut (57) onto rod (19).
3. Place shifter rod (19) through upper hole in shift lever (13) using plain nut (57) as a stop.
4. Replace hex lock nut (64) and tighten, leaving nut loose enough to allow the shifter rod to pivot freely in hole.
5. Be sure transmission is in neutral (second from the lowest position of shift rod weldment (29) on transmission).

NOTE: Unit will roll freely with transmission in neutral gear.

6. Remove cotter pin (18) and flatwasher (86) from lower end of shifter rod (19). Place rod through hole in shifter plate (20) and replace flatwasher (86) and cotter pin (18).

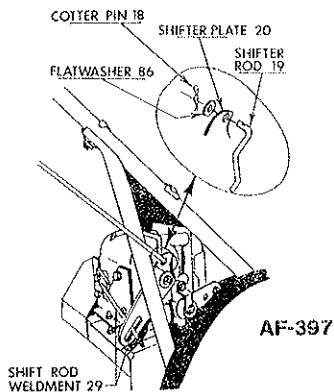

7. Slide bracket (12) back and forth until neutral stop tab is resting firmly against lower front edge of shift lever (13). Tighten hex lock nut (34).
8. Move shift lever (13) through the forward gears and back to the neutral stop position. Make sure unit is back in neutral.
9. If unit does not return to neutral, loosen hex lock nut (34) and repeat steps 5, 7 & 8.

CLUTCH ASSEMBLY AND ADJUSTMENT

1. Remove the snap clamp (56) securing the clutch cable (53) to the left middle handle (25).
2. Run the clutch cable (53) up the right hand upper handle (54) and assemble open loop of spring (55) through hole in tab of clutch grip (30).
3. Check to make sure the lower end of clutch cable is seated in the nylon pulley (78).

NOTE: Proper assembly of the clutch cable is important as it determines the adjustment of the clutch. Follow these instructions carefully to adjust clutch.

4. Loosen the fasteners on wire clamp (47) securing clutch cable (53) to the right middle handle (25).
5. Slide the black outer sheath of clutch cable (53) up or down so that the metal collar on top of sheath is 9½ inches down from the center of the hex hd. bolt (7) securing upper cross brace (8) to handles.
6. Measure down 11 inches from that same bolt and assemble snap clamp (56), removed in stop 1, to upper handle and clutch cable.
7. Measure up from the bottom of the middle handle (25) to the lowest edge of the wire clamp (47). This should be 5 inches.

NOTE: If adjustment is needed wire clamp (47) should be loosened enough to allow free movement over cable and handle without pulling or stretching black sheath.

8. Once clamp is properly set, hold in place and tighten fasteners.
9. This should be the correct setting and no further adjustment needed. To check, depress clutch grip (30), engaging clutch, the cable spring should be, almost or just touching nylon pulley (78).
10. If after inspection or operation the clutch would need adjustment, loosen the fasteners on the wire clamp (47). Moving the clamp upward on handle and cable will loosen the tension of clutch. Moving the clamp down will tighten clutch.

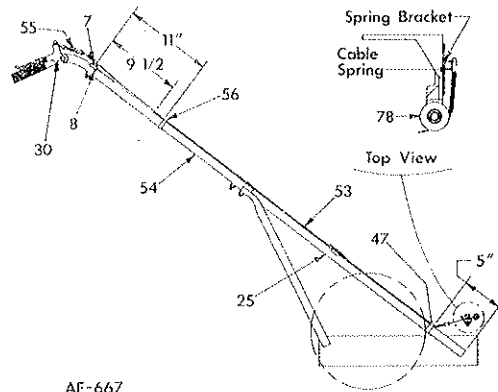

TO ASSEMBLE SPIN-PAK®

1. Remove the hex hd. bolts, lock nuts, and flatwashers, from the three upper holes used to secure the retaining ring to the blower housing. **DO NOT** remove the bottom bolt or the retaining ring from blower housing.
2. Align the holes in the Spin-Pak® with the three upper holes in the retaining ring and blower housing. Replace hardware removed in Step 1 and tighten.

ATTACHING DUST BAG

1. Attach Bag Hooks to upper Bag Straps and hook over upper handles above Upper Cross Brace.
2. Slip the neck of the dust bag over the Spin-Pak® until the tie strap can be pulled tight around the housing neck just over the bead on the Spin-Pak®. The bead must be covered.
3. Attach Bag Hooks to the front Bag Straps and hook over the lower cross brace. **IMPORTANT:** Failure to attach front Bag Straps to the lower crossbar will cause premature wear of bag around the bottom and around the neck at the Spin-Pak®. The Spin-Pak® may also break due to excessive weight from the Bag.

NOTE: FAILURE TO OBSERVE SAFETY INSTRUCTIONS MAY RESULT IN SERIOUS INJURY.

ASSEMBLY INSTRUCTIONS

ATTACHING INTAKE HOUSING

1. Insert the hinge bosses, on collar of intake housing, behind the hinge extension on front cover assembly.
2. Swing intake housing to lay flat against front cover assembly.
3. Secure by placing flatwasher and adjusting knob, on pivot bolt, over the collar of intake housing and tightening adjusting knob.

WARNING

Make a thorough inspection to see that all fastenings are tight and all parts are properly installed. **DO NOT** start engine without Intake Housing and Dust Bag in place.

OPERATING INSTRUCTIONS

TO START UNIT

WARNING: The engine contains NO OIL. Read the Engine Instruction Manual carefully before operating the VAC-35 KOHLER ENGINES. The stop switch is located on the handle.

Before starting the engine read and understand the following:

1. Be sure the engine crankcase is filled with the proper type and amount of oil.
2. Spin-Pak® is in place.
3. Dust Bag or Discharge Hose is in place.
4. Intake Housing or Hose Kit is attached to the Fan Housing.

If engine is started without intake attached, serious injury may result by drawing clothing or parts of the body into the fan.

If engine is run without dust bag, small stones or other objects may be picked up and propelled at operator or bystanders through the unprotected opening causing serious injury.

WARNING: When refueling care should be taken not to spill fuel on hot engine. This could cause the fuel to ignite, resulting in serious injury to operator or damage to the unit.

TRANSMISSION OPERATION

NOTE: Transmission has five forward speeds.

1. Transmission **MUST** be in NEUTRAL to start.
2. Move SAFETY STOP switch to ON position. After engine has started, release the BRAKE by twisting lever and letting it slide down.
3. Transmission used on this equipment is a tractor type (not automotive). The operator does not have to start in first gear and shift on up to gear required, he can go directly into the gear needed. It is also important to understand that the gears are designed to go into mesh (into gear) only when not turning. De-clutching (releasing clutch handle) is required at all times when gear selection occurs. Never shift on hills or inclined surfaces.
4. The operator should not shift with the unit under heavy load. In no case should an operator shift from first to neutral, from reverse to neutral, or from neutral to first or reverse, without de-clutching.

CLUTCH OPERATION

1. The unit is equipped with a "Dead Man" clutch. When the transmission is put in gear, and the clutch is depressed and held in the down position the unit will move. The unit will stop moving when the clutch is released.
2. TO STOP UNIT, PLACE GEAR SHIFT LEVER IN NEUTRAL, and move SAFETY STOP switch to OFF position. Pull up and twist brake lever 1/4 turn to lock in brake position. This brake is to be used as only a parking brake.

THROTTLE OPERATION AND ADJUSTMENT

1. The throttle control on handle is a remote for the throttle control on engine. Pull the throttle lever back, toward operator, to open throttle for starting or speed control. Move throttle lever forward to the closed position for lowest idle.
2. To stop unit move throttle lever to the closed position and engage electric stop switch.
3. If engine is not stopping easily or seems to idle too high; stop engine and let cool if hot. Move throttle lever to closed position and loosen boden wire screw. Move throttle lever on engine to full closed and retighten boden wire screw.
4. While operating, if throttle lever does not stay open due to vibration of unit, tighten friction screw until there is sufficient friction to hold throttle open.

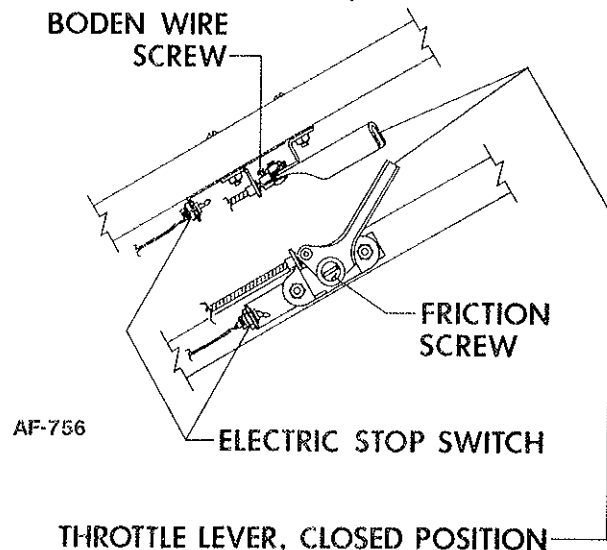

**BE SAFE. PROTECT YOUR FAMILY, YOUR FRIEND, YOURSELF.
OBSERVE ALL SAFETY INSTRUCTIONS.**

OPERATING INSTRUCTIONS

1. The efficiency of this unit depends on the breathing capacity of the Dust Bag. Under extremely dusty conditions the bag should be emptied and cleaned frequently. Always empty and clean bag before storing after use. Debris allowed to remain in the bag may cause spontaneous combustion, resulting in an explosion or fire.
2. Heavy concentrations of sand and gravel should be avoided. These materials are extremely abrasive, and while the VAC-35 will handle moderate amounts of these materials, it was not designed for heavy applications. Treat the VAC-35 with the reasonable care and it will provide long, trouble-free service.
3. The VAC-35 will handle most common kinds of debris found around industrial plants, commercial buildings, homes, and farms. Acid contaminated materials, magnesium, dust and other DANGEROUS DEBRIS should not be handled with the VAC-35 unless approved by a regulating authority expert in the handling of such hazardous materials.
4. When using hose attachment, keep it away from engine exhaust system and other parts of the engine that may be hot enough to burn plastic hose.

OPTIONAL ACCESSORIES

NOTE: Accessory Number and Price List can be obtained from a local distributor.

24" INTAKE HOUSING: For sweeping in narrow aisles or in areas where heavier objects are to be collected.

36" INTAKE HOUSING: Ideal for sweeping lighter weight debris and in larger, open areas.

HOSE ATTACHMENT 8" DIA.: 15 ft. length overall, fits all VAC-35 models. Attaches to impeller housing for cleaning debris from hard-to-reach areas.

HOSE ATTACHMENT 6" DIA.: 15 ft. length overall, fits all VAC-35 models. Attaches to impeller housing for cleaning debris from hard-to-reach areas.

HOSE ATTACHMENT 4" DIA.: 15 ft. length overall, fits all VAC-35 models. Attaches to impeller housing for cleaning debris from hard-to-reach areas.

SCRAPER BRUSH KIT: Installs inside rear or intake housing. Loosens debris which adheres to surface. (Available for 30" intake housing only.)

MAGNETIC ROD KIT: Assembles to front of intake housing. Attracts metal objects. (Available for 30" intake housings only.)

LUMITE® BAG: 10 cu. ft. capacity, polypropylene material. Won't fade, shrink, mildew or rot. Use when gathering damp or wet material.

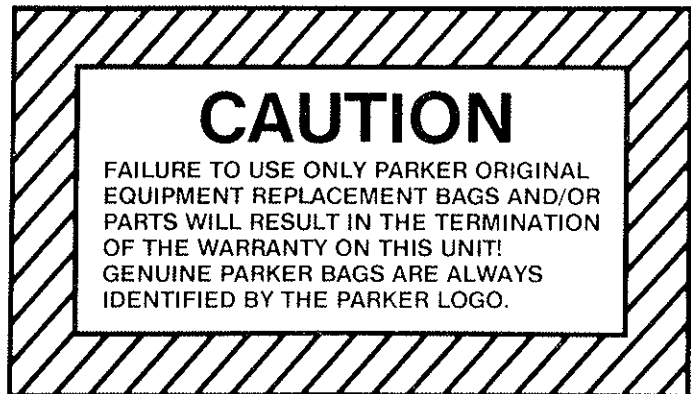

MAINTENANCE INSTRUCTIONS

LUBRICATION

1. Oil the Dual Caster Wheel Assembly where Axle Support Weldment assembles to Pivot Pin. Also oil Axle Weldments where they assemble through Axle Support Weldment.
2. Add a few drops of oil to the Throttle Control Cable and Wire to keep it operating smoothly.
3. Grease fittings are located in the hubs of the rear wheels. Fresh grease should be added periodically to assure proper lubrication of Wheels.

NOTE: Check all items once a week if unit is used daily.

NOTE: Refer to engine operating instructions for proper lubrication of the engine.

DUST BAG CARE

1. Keep the Dust Bag clean at all times.
2. To clean the Dust Bag, turn the bag inside out and reattach to the sweeper.
3. Start the engine and run at full throttle. Lightly tap the bag to release the dust trapped in the weave.

4. When the bag is clean, remove it and turn it right side out again. Reattach to the sweeper and resume sweeping.
5. DO NOT wash the Dust Bag to clean.

CHAIN TENSIONER ADJUSTMENT

1. The chain tensioner is adjusted properly at factory before shipment. Chain should be checked periodically for chain tension and wear on chain tensioner. If chain tensioner should need replaced or chain tension adjusted, follow these instructions.

NOTE: Round wooden "Roller" is not designed to "roll." It must be clamped tightly with bolt through casting. Chain side bars will cut guide grooves in roller and chain rollers will roll against wood, assuring proper chain adjustment and guidance without damage to chain.

2. Remove chain cover (15).
3. Loosen hex hd. bolt (39).
4. Slide the tensioner (63) forward (toward chain) until tensioner will not slide further.

NOTE: FAILURE TO OBSERVE SAFETY INSTRUCTIONS MAY RESULT IN SERIOUS INJURY.

MAINTENANCE INSTRUCTIONS

CHAIN TENSIONER ADJUSTMENT (continued)

5. Pull tensioner back 1/8" and retighten hex head bolt (39).
6. Check chain by pushing down and lifting chain between tensioner and differential sprocket.
7. Chain should move approximately 1/8" when checked. If chain is loose it will jump off sprocket. If too tight, chain may break or cause excessive wear on bearings.

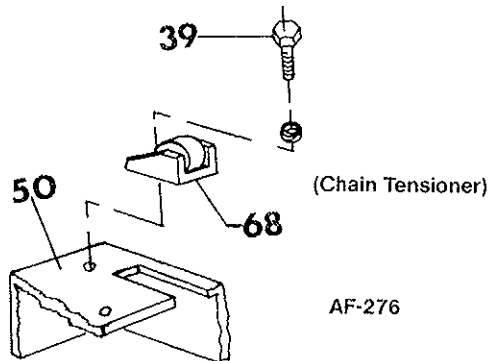

BELT ADJUSTMENT

Best adjustment is automatically controlled by an extension spring on the end of the clutch cable. With this system, belt tension is always correct, reducing belt wear and belt stretch.

BELT REPLACEMENT

1. Remove the spark plug to insure that engine cannot be started accidentally.
2. Belt can be replaced by removing the blower housing and fan.

Remove the following items to reach Belt:

1. Dust Bag (1) and Hooks (3)
2. Intake housing (14)
3. Front cover (8)
4. Fan (5)
5. Spin-Pak®
6. Fan Housing (1)
7. Guard (37)

WARRANTY INFORMATION

Parker Sweeper Company warrants each new piece of equipment manufactured under its name except engines, transmissions and differentials where applicable to be free from defects in materials and workmanship under normal use and service. Parker Sweeper Company's obligation is limited to repair or replacement, at its option for one (1) year (ninety (90) days for commercial service) from date of purchase.

If trouble should occur with the engine, please contact the manufacturer, giving them all information: Name of unit, purchased from company, (PV-8708-K-SP, Parker Sweeper Co., etc.); problem with engine, model number of engine, etc.; when unit was purchased; and a complete return address with zip code. Failure to provide complete information will result in unnecessary delay of repair and return of unit. The following is a list of companies that supply Parker Sweeper Co. with various products. Please contact the companies directly at the address listed if any problems should occur.

All parts listed are under the manufacturer's name and part number. Replacement parts should be purchased

directly from each company listed with a complete description of the part and part number. Addresses of manufacturers who stock parts are listed below.

Parts listed under the Standard Parts can be purchased from most hardware stores.

Proper assembly of replacement parts is the responsibility of the owner or mechanic doing the work. Parker Sweeper Company warranty only applies to the original purchased unit and/or replacement parts if assembled correctly by a qualified mechanic. Under no circumstances does the warranty extend beyond the original time specified from date of purchase.

ENGINES

Kohler Co.
Kohler, Wisconsin 27249

TRANSMISSION & DIFFERENTIAL

Peerless Gear & Machine Division
P.O. Box 620
Clinton, Michigan 49236-0620

HOW TO ORDER REPAIR PARTS

NOTE: When ordering service parts for any model VAC, follow the instructions listed below. By so doing, you will be assured of receiving the correct part in the shortest possible time.

1. Give the model and serial number found on the back of fan housing or back of chassis on the unit.
2. Write the complete part number as well as the description of the part, and quantity of part required.

3. Give detailed shipping instructions, that is: whether shipment is to be parcel post, United Parcel Service, air express, freight or truck.

NOTE: Parker Sweeper Co. is continually striving to improve its products. We must, therefore, reserve the right to make improvements or changes, when it becomes practical and possible to do so, without incurring any obligation to make changes or additions to the equipment previously sold.

READ SAFETY & OPERATING INSTRUCTIONS BEFORE OPERATING EQUIPMENT.

HANDLE ASSEMBLY

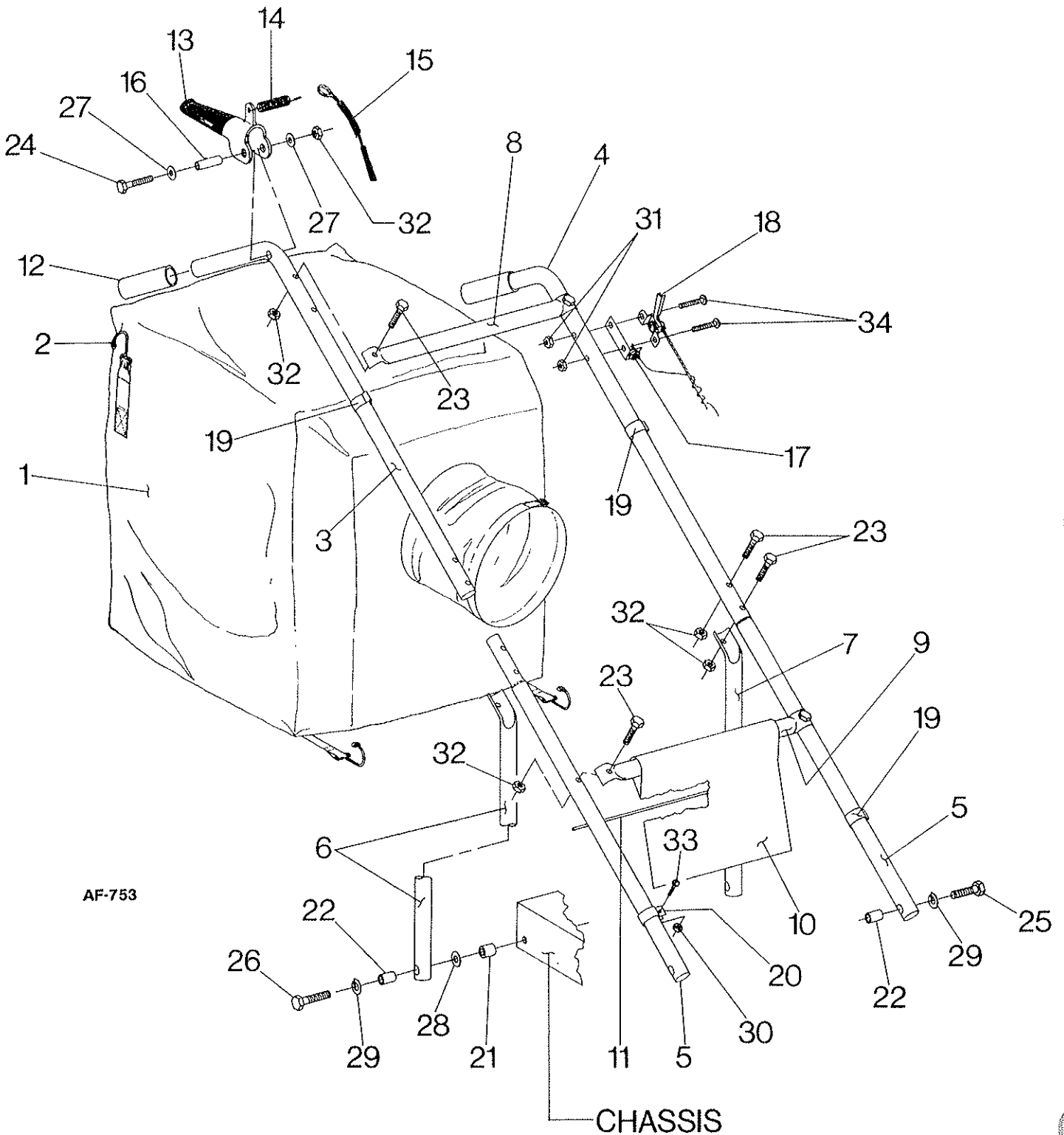

HANDLE ASSEMBLY

PARTS LIST

Ref. No.	Part No.	Qty. Per Unit	Description
1	MA-585	1	Dust Bag
* 2	63-304-A	4	Bag Hook
3	81-23-C	1	Upper Handle R.H.
4	83-18-C	1	Upper Handle L.H.
5	82-242-B	2	Middle Handle
6	85-09-RC	1	Back Brace R.H.
7	85-09-LC	1	Back Brace L.H.
8	81-04-B	1	Cross Brace, Upper
9	81-47-B	1	Cross Brace, Lower
10	80-237-A	1	Bag Guard
11	86-157-B	1	Bag Guard Retainer
12	80-232-A	2	Handle Grip
13	SA-1176-A	1	Clutch Grip Assembly
14	74-167-A	1	Spring
15	82-84-A	1	Clutch Cable
16	80-225-A	1	Spacer
17	SA-1175-B-45	1	Stop Switch Assembly
18	83-25-B-49	1	Throttle Control Assembly
19	80-276-A	3	Clamp, Snap-on
20	81-88-A	1	Wire Clamp
21	83-35-A	2	Spacer
22	80-238-A	4	Insert
Items listed below should be purchased through a local hardware store.			
23	65-416-24	8	Bolt, Hex Hd. 1/4-20 x 1 1/2
24	65-416-32	1	Bolt, Hex Hd. 1/4-20 x 2
25	65-516-28	2	Bolt, Hex Hd. 5/16-18 x 1 3/4
26	65-516-40	2	Bolt, Hex Hd. 5/16-18 x 2 1/2
27	945-416	2	Flatwasher, Plain 1/4
28	945-516	2	Flatwasher, Plain 5/16
29	935-516	4	Lockwasher, Spring 5/16
30	365-8	1	Nut, Hex Lock #8-32
31	365-10	2	Nut, Hex Lock #10-24
32	365-416	9	Nut, Hex Lock 1/4-20
33	515-8-8	1	Screw, Rd. Hd. Mach. #8-32 x 1/2
34	515-10-24	2	Screw, Rd. Hd. Mach. #10-24 x 1 1/2

*Supplied with item 1, Dust Bag, but can be purchased separately.

CHASSIS & DRIVE ASSEMBLY

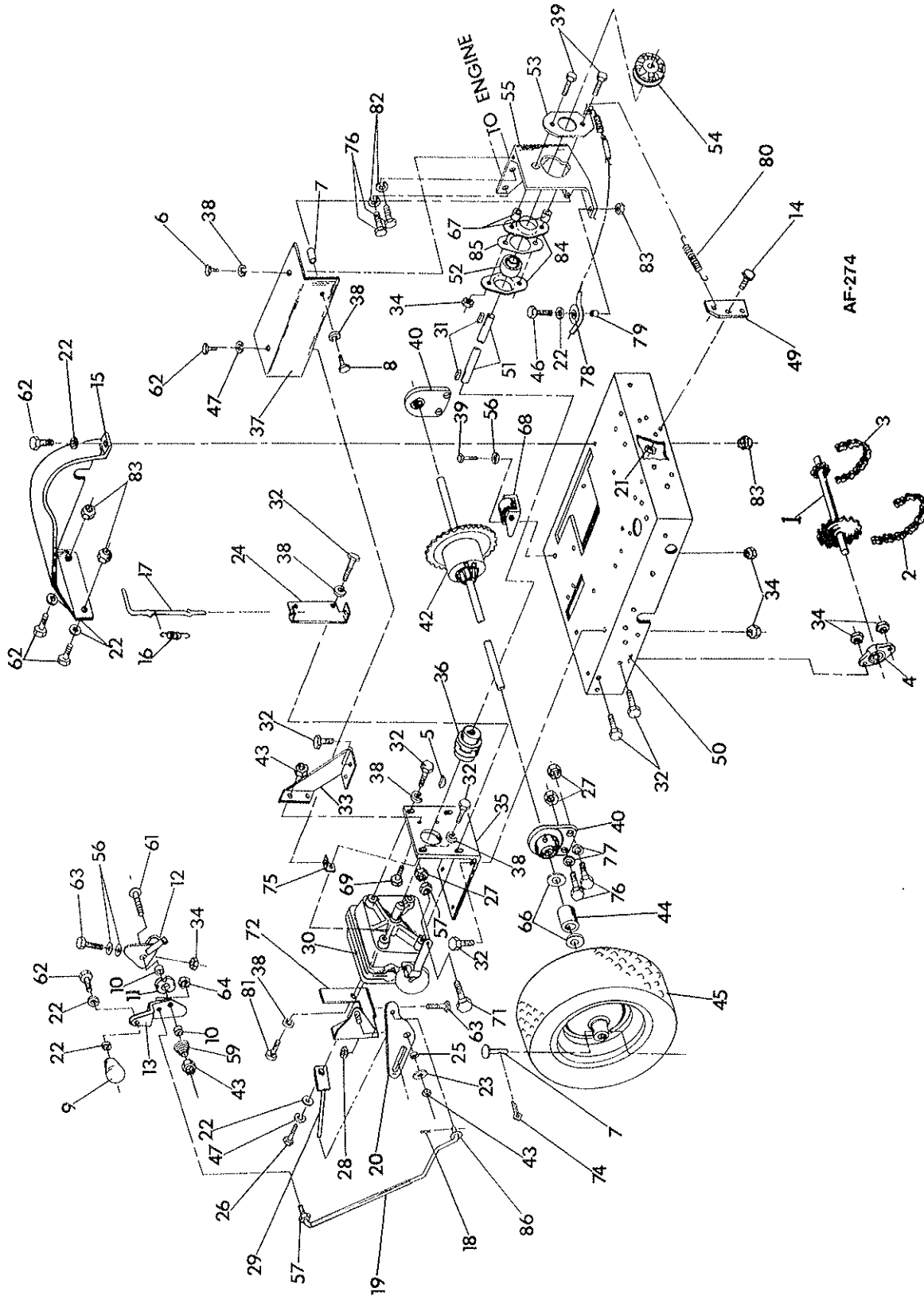

CHASSIS & DRIVE ASSEMBLY**PARTS LIST**

Ref. No.	Part No.	Qty. Per Unit	Description	Ref. No.	Part No.	Qty. Per Unit	Description
1	81-25-B	1	Jack Shaft	45	68-310-B	2	Wheel Assembly
2	84-41-B32	1	Chain, Roller #41-32-P		68-311-B	2	• Wheel
3	84-41-B48.5	1	Chain Roller #41-48.5-P		68-312-A	2	• Tire 5.30/4.50 x 6
4	74-116-A	2	Bearing Assy. Side Flange	*46	65-416-16	1	Bolt, Hex Hd. 1/4-20 x 1
* 5	280-09	1	Woodruff Key #9	*47	935-416	2	Lockwasher, Spring 1/4
* 6	72-516-12	1	Bolt, Self Tapping 5/16-18 x 1/2	49	82-159-B	1	Spring Support Bracket
7	81-10-A	1	Spacer	50	81-19-D	1	Chassis
* 8	72-516-16	1	Bolt, Self Tapping 5/16-18 x 1	51	82-40-A	1	Drive Shaft
9	75-79-A	1	Shifter Knob	52	66-138-A	1	Seal Master Bearing
10	54-227-A	2	Spacer	53	81-43-A	1	Spring Bracket
11	68-28-A	1	Cupped Washer	54	74-86-A	1	Drive Sheave
12	82-137-A	1	Stop & Bracket	55	82-16-C	1	Clutch Bracket
13	70-67-B	2	Shift Lever	*56	945-516	3	Flatwasher, Plain 5/16
*14	65-416-10	2	Bolt, Hex Hd. 1/4-20 x 5/8	*57	335-616	2	Nut, Plain Hex 3/8-16
15	82-195-D	1	Chain Guard	59	80-162-A	1	Shifter Spring
16	74-167-A	1	Spring, Brake	*61	515-516-12	1	Screw, Rd. Hd. Mach 5/16-18 x 3/8
17	74-96-A	1	Brake Lever	*62	65-416-8	5	Bolt, Hex Hd. 1/4-20 x 1/2
18	57-110-A	1	Cotter Pin	*63	65-516-24	2	Bolt, Hex Hd. 5/16-18 x 1 1/2
19	82-227-B	1	Shifter Rod	*64	364-616	1	Nut, Hex Lock (Thin) 3/8-16
20	83-29-A	1	Shifter Plate	66	66-431-A	4	Washer, Special
*21	365-416	2	Nut, Hex Lock 1/4-20	67	81-42-A	2	Spacer
*22	945-416	7	Flatwasher, Plain 1/4	68	SA-968-A	1	Tensioner & Roller Assy.
23	76-36-A	1	Washer, Special	*69	65-516-10	2	Bolt, Hex Hd. 5/16-18 x 5/8
24	82-164-D	1	Brake Bracket	*71	65-616-20	1	Bolt, Hex Hd. 3/8-16 x 1 1/4
25	83-35-A	1	Spacer	72	82-141-B	1	Adjusting Plate
*26	60-416-10	1	Bolt, Hex Hd 1/4-24 x 5/8	73	80-44-A	2	Clevis Pin
*27	365-616	5	Nut, Hex Lock 3/8-16	*74	380-332-8	2	Cotter Pin
*28	335-516	1	Nut, Plain Hex 5/16-18	75	80-32-A	1	Bracket & Nut
29	82-134-B	1	Shift Rod Weldment	*76	65-616-16	6	Bolt, Hex Hd. 3/8-16 x 1
**30	SA-857-A	1	Transmission	77	81-166-A	4	Washer, Special
31	48-277-A	2	Key, 3/16 Square	78	81-44-A	1	Nylon Pulley
*32	65-516-12	14	Bolt, Hex Hd. 5/16-18 x 3/4	79	81-45-A	1	Spacer
33	82-20-C	1	Transmission Bracket Brace	80	81-31-A	1	Spring
*34	365-516	14	Nut, Hex Lock 5/16-18	*81	72-516-12	3	Bolt, Self Tapping 5/16-18 x 3/4
35	82-15-D	1	Transmission Bracket	*82	935-616	2	Lockwasher, Spring 3/8
36	74-114-A	1	Flexible Coupling	*83	364-416	4	Nut, Hex Lock (Thin) 1/4-20
37	81-83-D	1	Shaft Guard	84	66-139-A	2	Flange Bearing
*38	935-516	9	Lockwasher, Spring 5/16	85	81-40-A	1	Bearing Spacer
*39	65-516-16	3	Bolt Hex Hd. 5/16-18 x 1	*86	945-616	1	Flatwasher, Plain 3/8
40	SA-816-B	2	Bearing Assy.				
42	SA-1243-D	1	Differential Assy.				
*43	364-516	4	Nut, Hex Lock (Thin) 5/16 18				
44	74-168-A	2	Wheel Spacer				

*These items should be purchased through a local hardware store.

**(See Transmission Page)

HOUSING UNIT ASSEMBLY

AF-746

Torque to 45 - 49 ft. lbs.; There must be no lubrication, except plating, on engine shaft, washers 14 & 37, or this bolt.

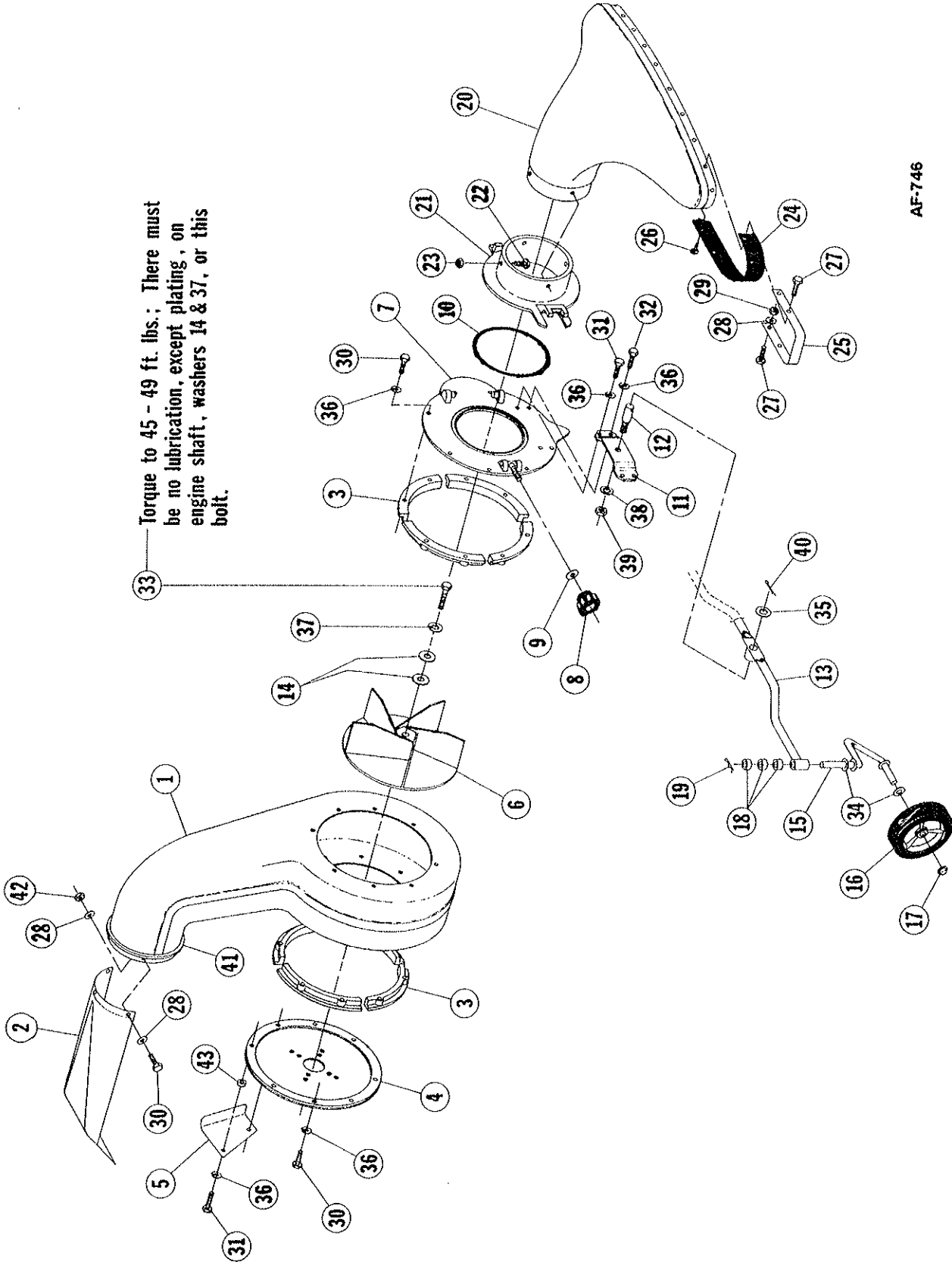

HOUSING UNIT ASSEMBLY

PARTS LIST

Ref. No.	Part No.	Qty. Per Unit	Description
1	70-103-D	1	Housing Assembly
2	85-110-B	1	Spin-Pak®
3	64-78-C	8	Anti-Wrap Segment
4	84-346-C	1	Back Plate & Gasket
5	72-241-B	1	Heat Shield
6	72-175-D	1	Fan Wheel
7	SA-1389-D	1	Front Cover Assembly
* 8	80-29-A	1	• Adjusting Knob
* 9	945-816	1	• Flatwasher, Plain 1/2
*10	63-190-A	1	• O-Ring Gasket
11	73-89-B	1	Mount Plate
12	73-94-A	1	Pivot Pin
13	83-211-B	1	Axle Support Weldment
14	82-138-B-3	2	Special Washer
15	86-108-B	2	Axle Weldment
16	84-300-C	2	Wheel
17	76-254-A	2	End Cap
18	79-16-A	6	Spacer
19	81-106-A	2	Cotter Pin
20	MA-251-D	1	30" Intake Housing Assembly
**21	63-195-D	1	Collar

Items listed below should be purchased through a local hardware store, except items 24, 25, 26, 33, 41 and 43.

**22	65-416-10	4	Bolt, Hex Hd. 1/4-20 x 5/8
**23	369-416	4	Nut, Serrated Hex Lock 1/4-20
**24	73-67-D	1	Skirt
**25	62-98-C	2	Guard
**26	80-332-A	15	Fastener
**27	65-416-12	8	Bolt, Hex Hd. 1/4-20 x 3/4
**28	945-416	16	Flatwasher, Plain 1/4
**29	364-416	8	Nut, Hex Lock (thin) 1/4-20
30	65-416-16	14	Bolt, Hex Hd. 1/4-20 x 1
31	65-416-20	4	Bolt, Hex Hd. 1/4-20 x 1 1/4
32	65-416-24	2	Bolt, Hex Hd. 1/4-20 x 1 1/2
***33	60-716-16	1	Bolt, Hex Hd. 7/16-20 x 1
34	945-816	4	Flatwasher, Plain 1/2
35	945-1216	1	Flatwasher, Plain 3/4
36	935-416	16	Lockwasher, Spring 1/4
37	935-716	1	Lockwasher, Spring 7/16
38	936-816	1	Lockwasher, Int. Tooth 1/2
39	345-816	1	Nut, Hex Jam 1/2-20
40	380-532-20	1	Cotter Pin 5/32 x 1 1/4
41	85-59-C	1	Retaining Ring
42	365-416	4	Nut, Hex Lock 1/4-20
43	54-227-A	2	Spacer

*Items 8, 9 & 10 are supplied with item 7, but may be purchased separately.

**Items 21 through 29 are supplied with item 20, but may be purchased separately.

***Item 33, Torque to 45 to 49 ft. lbs.

ENGINE ASSEMBLY

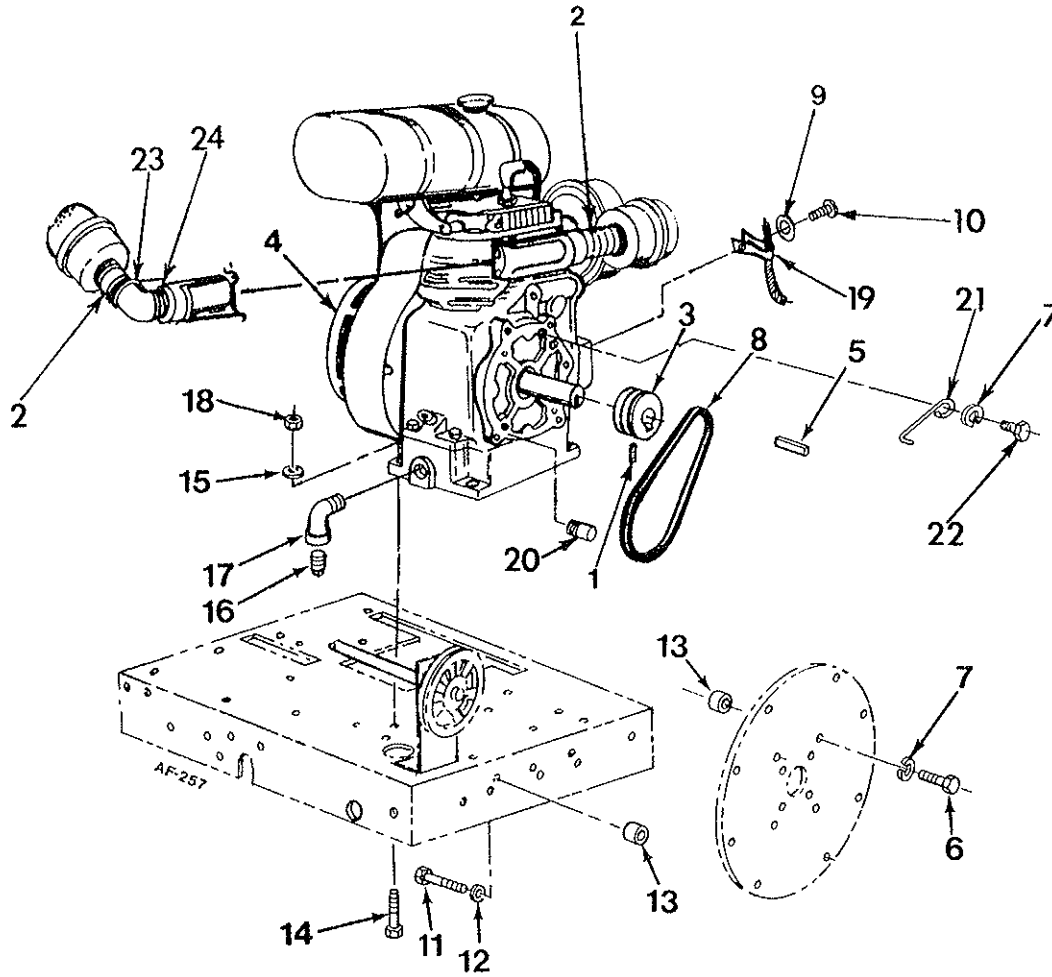

PARTS LIST

Ref. No.	Part No.	Qty. Per Unit	Description	Ref. No.	Part No.	Qty. Per Unit	Description
*** 1	564-416-8	1	Screw, Set 1/4-20 x 1/2	13	79-139-A	6	Spacer, Back Cover
2	67-68-A	1	Pipe Nipple 1 x 4	***14	65-616-20	4	Bolt, Hex Hd. 3/8-16 x 1 1/4
3	81-61-A	1	Engine Pulley	***15	945-616	4	Flatwasher, Plain 3/8
* 4		1	Engine, Kohler	16	**	1	Plug, Oil Drain
5	74-112-A	1	Fan Key 1/4-2 1/2	17	57-81-A	1	Street Elbow 1/2-90°
*** 6	65-616-24	4	Bolt, Hex Hd. 3/8-16 x 1 1/2	***18	365-616	4	Nut, Hex Lock 3/8-16
*** 7	935-616	5	Lockwasher, Spring 3/8	19	75-115-A	1	Throttle Cable Clip
8	73-417-A	1	V-Belt 3 L-210	20	81-32-A	1	Belt Popper
*** 9	935-8	1	Lockwasher, Spring #8	21	81-33-A	1	Belt Popper
***10	515-8-8	1	Screw Rd. Hd. Mach. #8-32 x 1/2	***22	65-616-12	1	Bolt, Hex Hd. 3/8-16 x 3/4
***11	65-416-28	2	Bolt, Hex. Hd. 1/4-20 x 1 3/4	23	69-125-A	1	Street Elbow 1 x 45°
***12	935-416	2	Lockwasher, Spring 1/4	24	73-240-A	1	Conduit Locknut 1"

*Kohler Model No. K-181-T, Spec. 30814

**Supplied with engine

***These items should be purchased through a local hardware store.

PEERLESS DIFFERENTIAL
MODEL 100-038

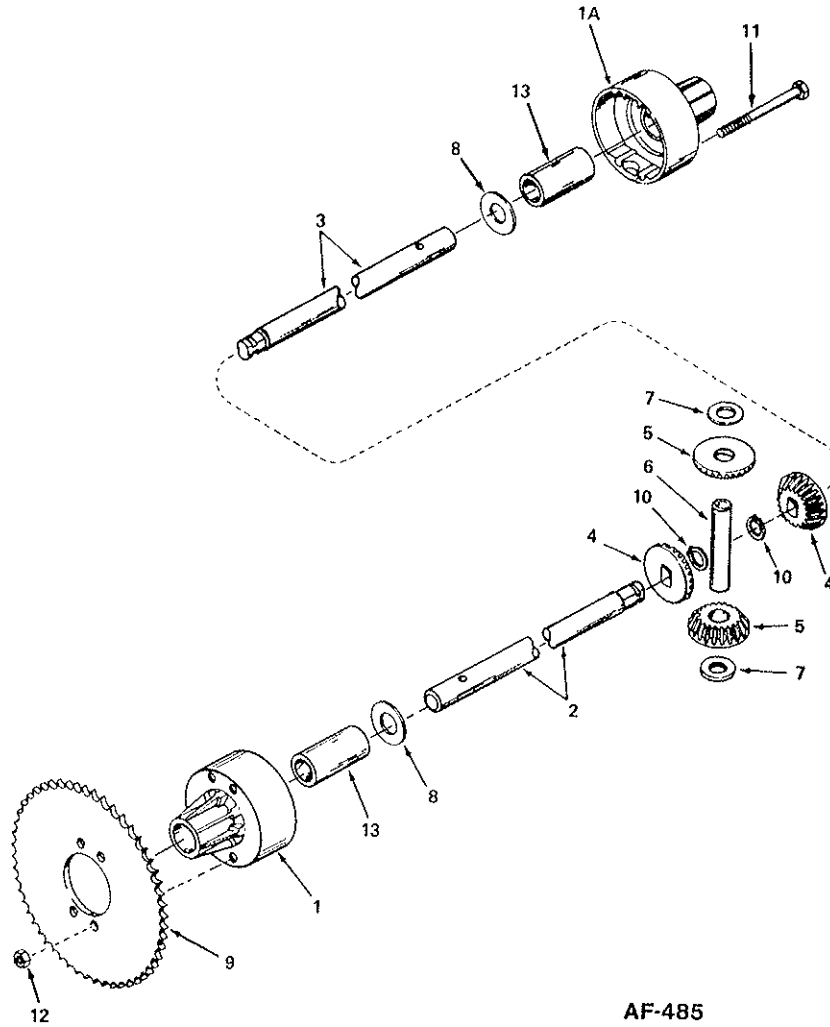

AF-485

Ref. No.	Part No.	Description
1	774484	Housing, Differential carrier (Incl. No. 13)
1A	774485	Housing, Differential carrier (Incl. No. 13)
2	774583	Axle (8-3/4" long)
3	774584	Axle (18-1/8" long)
4	778067	Gear, Bevel
5	778068	Gear, Pinion
6	786040	Pin, Drive
7	780096	Washer, Thrust
8	780001	Washer
9	1549-P1	Sprocket
10	792018	Ring, Snap
11	792041	Screw, Flanged Hex Hd., 5/16-18 x 3-3/4
12	792042	Nut, Lock, 5/16-18
13	780077	Bushing

PEERLESS TRANSMISSION

MODEL 750-A

Five Speed

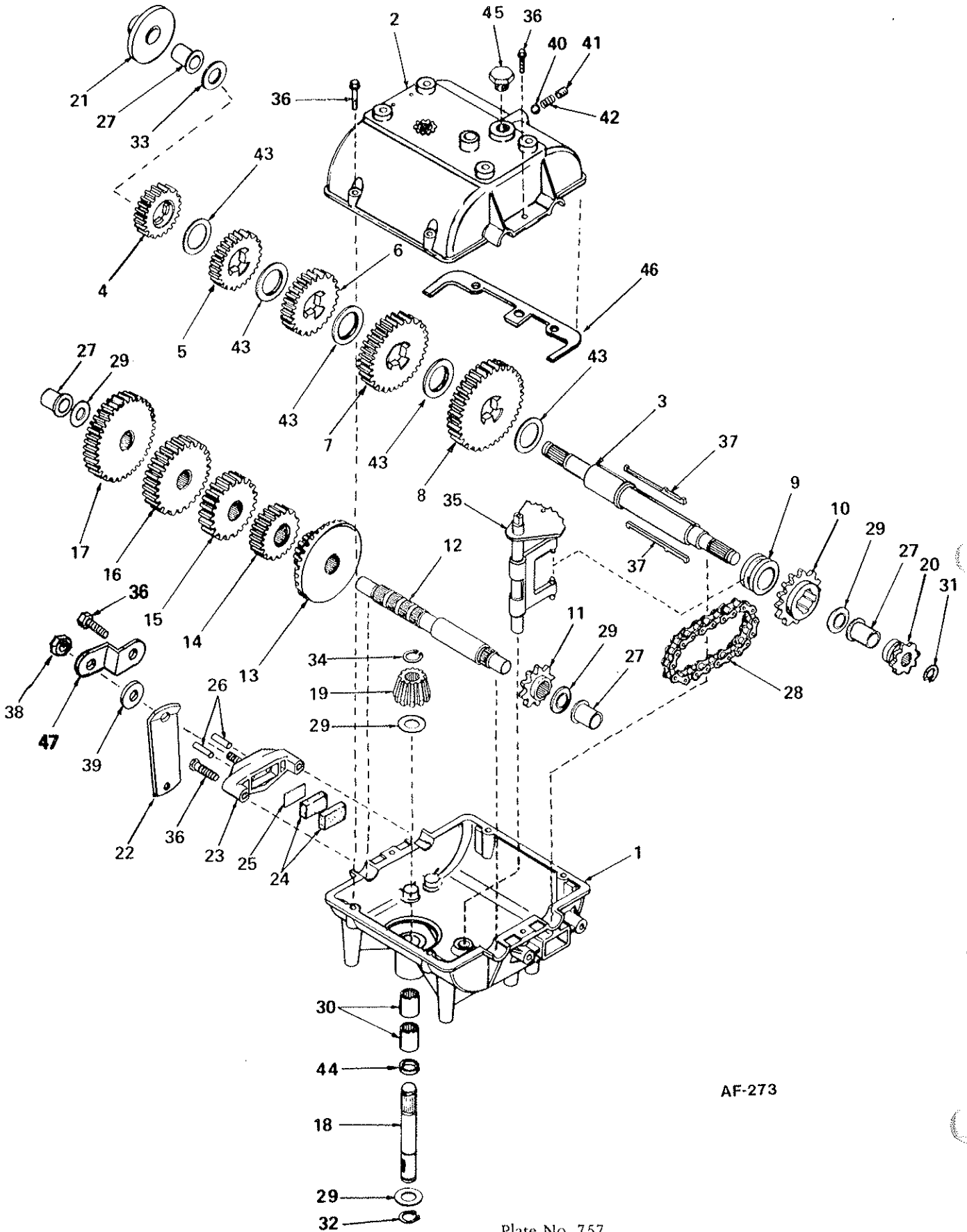

AF-273

REPAIR PARTS

PEERLESS "750"-A TRANSMISSION

PARTS LIST

Ref. No.	Part No.	Description
1	770061	Case, Transmission
2	772083	Cover, Transmission
3	776161	Shaft, Output & Brake
4	778121A	Gear, Spur (20 teeth)
5	778122A	Gear, Spur (22 teeth)
6	778123A	Gear, Spur (25 teeth)
7	778124A	Gear, Spur (30 teeth)
8	778125	Gear, Spur (35 teeth)
9	784266	Collar, Shift
10	786060	Sprocket (14 teeth)
11	786061	Sprocket (10 teeth)
12	776134	Shaft, Counter
13	778109	Gear, Bevel (42 tooth & 15 tooth spur gear)
14	778126A	Gear, Spur (20 teeth)
15	778127A	Gear, Spur (25 teeth)
16	778128A	Gear, Spur (28 teeth)
17	778129A	Gear, Spur (30 teeth)
18	776135	Shaft, Input
19	778113A	Bevel Pinion, Input
20	786047	Sprocket (8 teeth)
21	790003	Disk, Brake
22	790013	Lever, Brake
23	790025	Holder, Brake pad
24	790006	Pad, Brake
25	790007	Plate, Brake pad
26	786026	Pin, Dowel
27	780105A	Bushing, Flanged
28	786062	Chain, Roller (No. 41 chain, 22 links)
29	780072	Washer, Thrust
30	780086	Bearing, Needle
31	792072	Ring, Retaining
32	792035	Ring, Retaining
33	780109	Washer
34	788040	Ring, Retaining
35	784267	Rod & Fork Assy., Shift
36	792073	Screw, Hex. Hd. Tapite, 1/4-20x2 1/4
37	792089A	Key
38	792075	Nut, Lock, 5/16-24
39	792076	Washer, Flat, 5/16
40	792077	Ball, Steel, 5/16"
41	792078	Screw, Set, 3/8-16x3/8
42	792079	Spring
43	780108	Washer, Thrust
44	792001	"O" Ring
45	792074	Plug
46	788054	Gasket
47	786046	Bracket

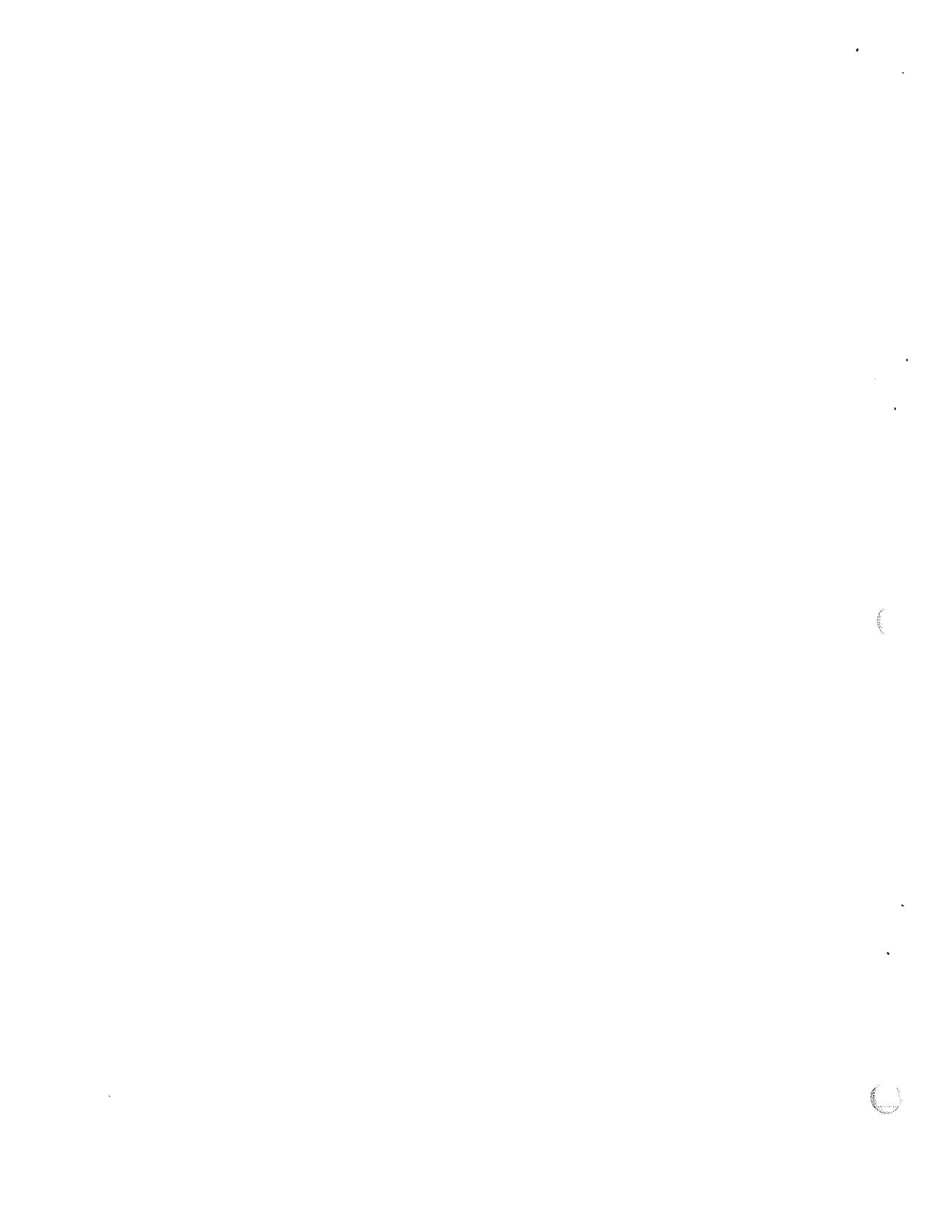

INDUSTRIAL PACKAGE MA-643-D



PARKER SWEEPER COMPANY

Box 1728

Springfield, Ohio 45501-1728

ASSEMBLY INSTRUCTIONS

NOTE: Numbers in parenthesis refer to those used in AF-786 and AF-787 in these instructions, and AF-781 on reverse side of this sheet.

ASSEMBLING FRONT CASTER

1. Place a block of wood or a brick under front of Chassis to hold Fan Housing off floor.
2. Remove four Bolts and Lockwashers from lower holes in Front Cover of Fan Housing.
3. Check to make sure holes in Anti-Wrap Segments inside Fan Housing are still in line with holes in Front Cover.
4. Assemble two longer Bolts and Lockwashers through lower holes in Caster Bracket (11), Front Cover and Anti-Wrap Segments.
5. Assemble remaining Bolts and Lockwashers through upper holes.
6. Thread stem of Caster (12) up through Caster Bracket (11).
NOTE: After all assembly is complete the height of the Intake Housing can be adjusted as follows.
7. To lower Intake Housing thread stem of Caster (12) farther into Caster Bracket (11).
8. Thread stem of Caster (12) out of Caster Bracket (11) to raise Intake Housing.
9. It may be necessary to adjust Intake Housing a few times before finding the proper setting, depending on the material being picked up.
10. When desired height is obtained, tighten Jam Nut (20) up against bottom of Caster Bracket (11) to lock Caster (12).

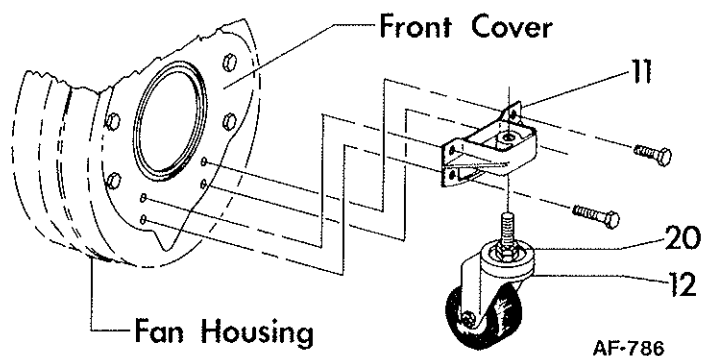

2. Pull Back Brace from Chassis, leaving Bolt in tubing.
3. Assemble one Special Washer (21) and Spacer (10) onto Bolt.
4. Assemble End Cap (9) onto Bolt, over Spacer (10), with flat edge of End Cap (9) toward Chassis.
5. Assemble another Special Washer (21) onto Bolt.
6. Insert Bolt back through hole in Chassis and secure with Hex Lock Nut.
7. Repeat for opposite side.

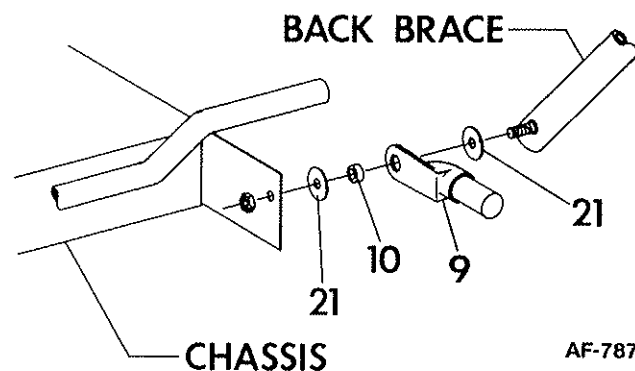

8. Place ends of Frame (1) onto End Caps (9) and align holes.
9. Place one Contour Hd. Bolt (15) through each hole and secure with Lockwashers (16) and Hex Nuts (17).
10. Lift back of Frame (1) and hold one Caster Assembly against bottom, in either corner.
11. Round edge and holes of Caster Plate (3) should align with outer edge and holes in corner of Frame (1).
12. Place Contour Hd. Bolt (15) through each hole and secure with Lockwashers (16) and Hex Nuts (17).
13. Repeat steps 10 thru 12 for other Caster.

Complete all other assembly as outlined in main Owner's Guide before attaching Dust Bag.

ASSEMBLING BAG PLATFORM

1. Remove the Hex Lock Nut from Bolt securing Back Brace to Chassis, on either side.

NOTE: See Instruction Sheet packed with Dust Bag to assemble Dust Bag.

INDUSTRIAL PACKAGE MA-643-D

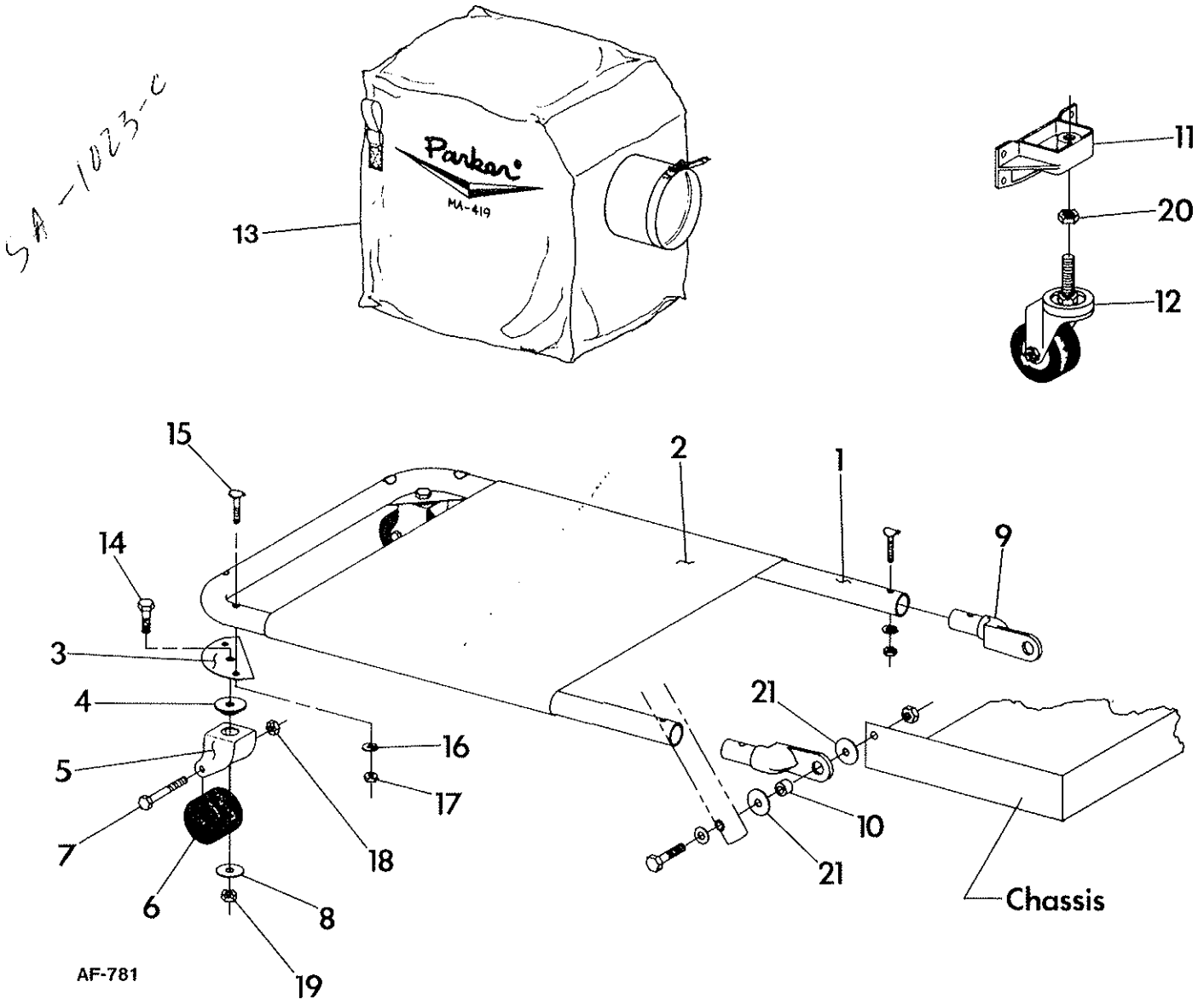

PARTS LIST

Ref. No.	Part No.	Qty. Per Unit	Description	Ref. No.	Part No.	Qty. Per Unit	Description
1	81-96-B	1	Frame	12	64-71-A	1	Caster, Stem Type
2	81-117-C	1	Bag Platform	*13	MA-419	1	Dust Bag
3	82-02-B	2	Caster Plate	14	65-516-16	2	Bolt, Hex Hd. 5/16-18 x 1
4	78-130-A	2	Caster Bearing	15	69-416-24	6	Bolt, Cont. Hd. 1/4-20 x 1 1/2
5	76-136-B	2	Fork	16	935-416	6	Lockwasher, Spring 1/4
6	81-79-A	2	Roller	17	335-416	6	Nut, Plain Hex 1/4-20
7	76-202-A	2	Axle	18	365-416	2	Nut, Hex Lock 1/4-20
8	82-138-B-1	2	Special Washer	19	365-516	2	Nut, Hex Lock 5/16-18
9	81-116-A	2	End Cap	20	340-1216	1	Nut, Hex Jam 3/4-10
10	81-120-A	2	Spacer	21	76-36-A	4	Special Washer
11	66-430-C	1	Caster Bracket				

*MA-419 Dust Bag is supplied with 63-304-A Bag Hooks, these can be purchased separately.