

CHASSIS & DRIVE ASSEMBLY

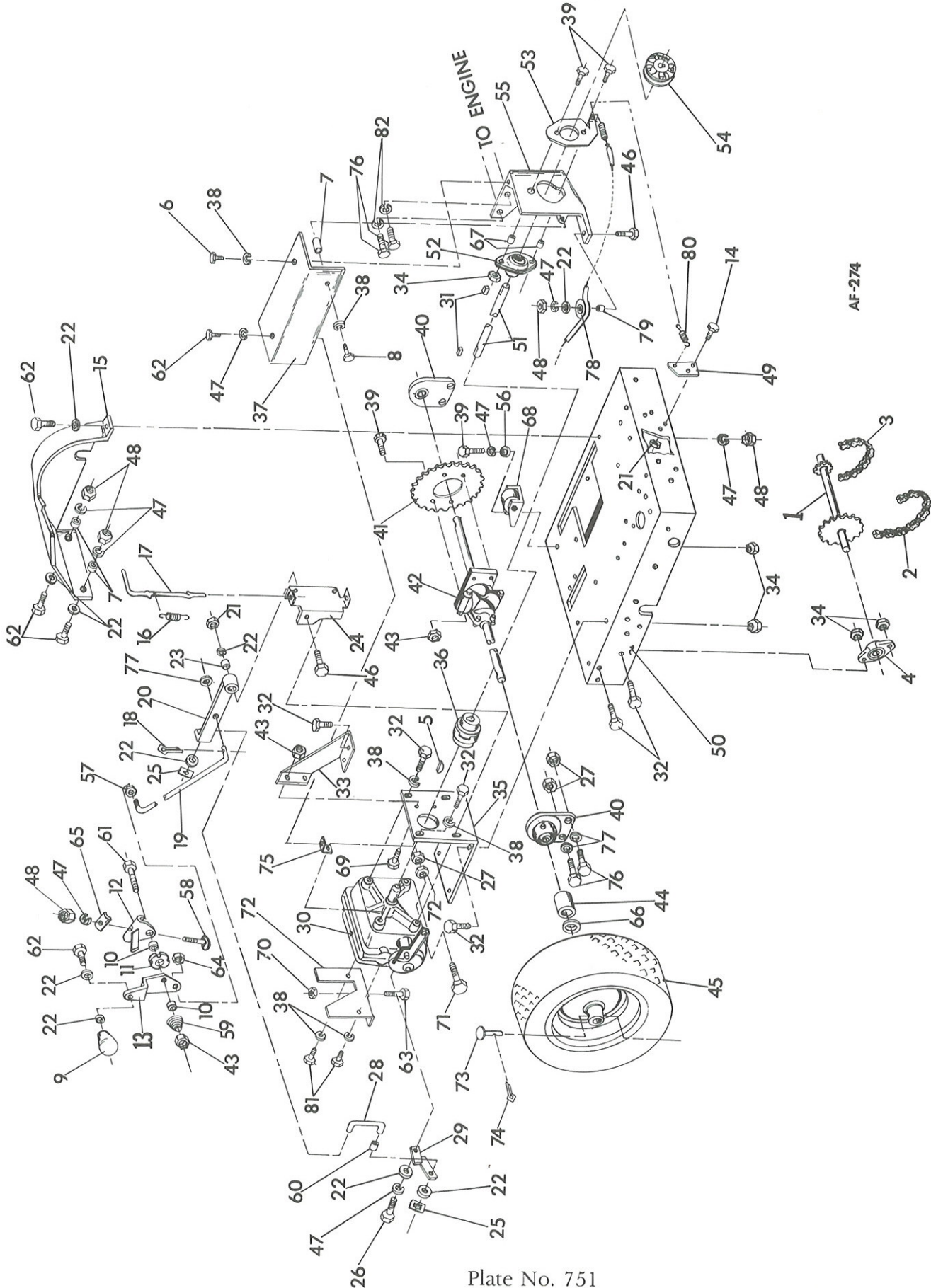
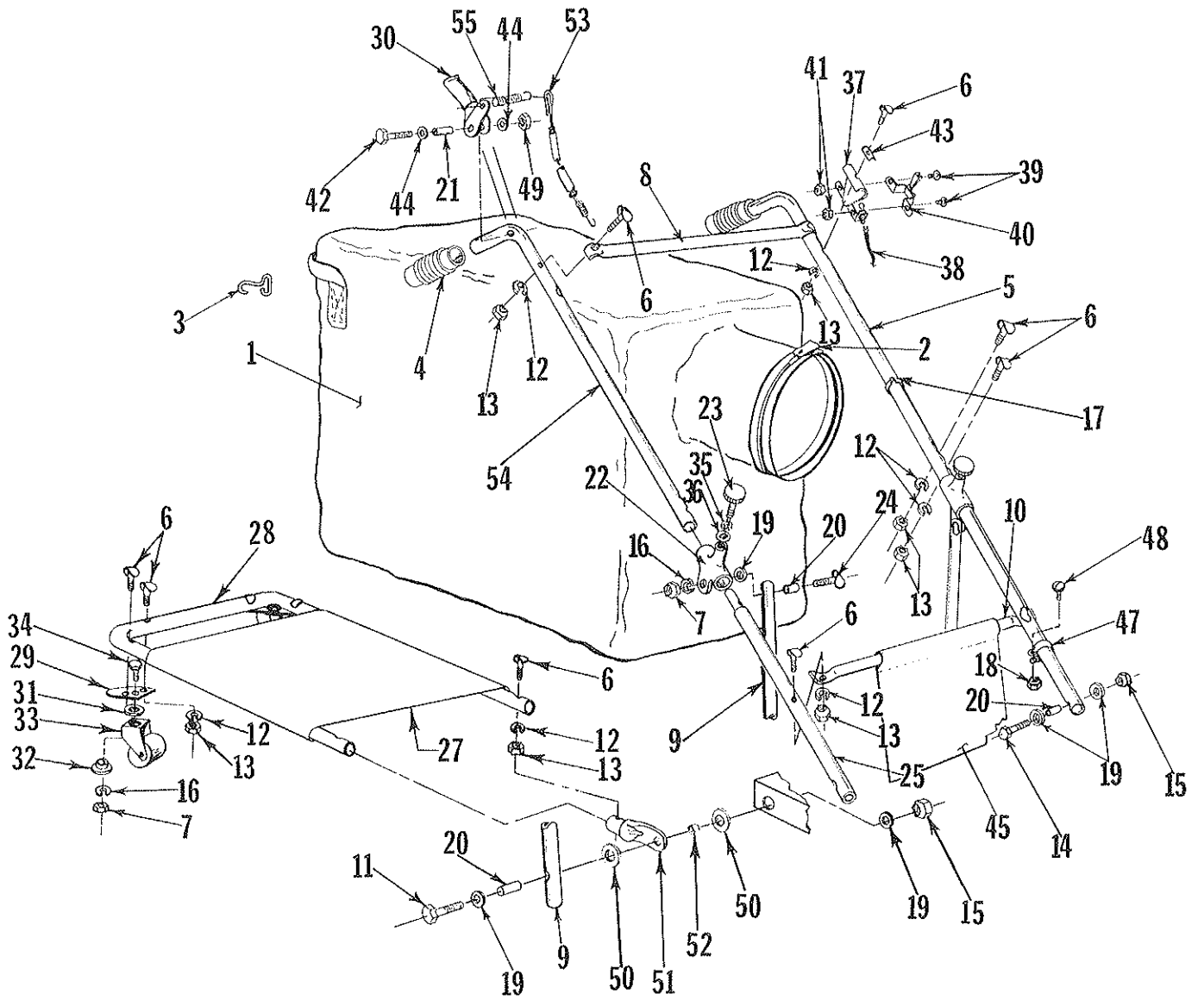

Plate No. 751

CHASSIS & DRIVE ASSEMBLY

PARTS LIST

Ref. No.	Part No.	Qty. Per Unit	Description	Ref. No.	Part No.	Qty. Per Unit	Description
1	81-25-B	1	Jack Shaft Weldment	42	SA-459-B	1	Differential Assembly MA-580-C
2	74-117-A	1	Chain, Roller #41-32p 89-41-32-83		364-516	7	Nut, 5/16-18 Hex Lock Thin
3	74-118-A	1	Chain, Roller #41-50p 89-41-50-85	44	74-168-A	2	Wheel Spacer
4	74-116-A	2	Bearing Assy. Side Flange	45	63-310-B	2	Wheel Assembly
5	280-09	1	#9 Woodruff Key Supplied		68-311-B	2	Wheel
6	61-516-8	1	Bolt 5/16-18x $\frac{1}{2}$ Self Tapping		68-312-A	2	Tire 5.30/4.50x6
7	81-10-A	3	Spacer	46	65-416-24	2	Bolt, 1/4-20x1 $\frac{1}{2}$ Hex. Hd.
8	61-516-14	1	Bolt 5/16-18x $\frac{7}{8}$ Self tapping	47	935-416	8	Lockwasher 1/4 Spring
9	75-79-A	1	Shifter Knob	48	335-416	6	Nut, 1/4-20 Hex Plain
10	54-227-A	2	Spacer	50	81-19-D	1	Chassis
11	68-28-A	1	Cupped Washer	51	82-40-A	1	Drive Shaft
12	80-287-A	1	Stop & Bracket Weldment	52	66-138-A	1	Seal Master Bearing 66-41-A
13	70-67-A	1	Shift Lever	53	81-43-A	1	Spring Bracket
14	65-416-10	2	Bolt 1/4-20x5/8 Hex. Hd.	54	74-86-A	1	Sheave, Drive
15	80-206-D	1	Chain Guard 82-195-D	55	82-16-c	1	Clutch Bracket
16	74-167-A	1	Spring, Brake	56	945-516	1	Washer 5/16 flat
17	74-96-A	1	Brake Lever	57	335-616	1	Nut, 3/8-16 Hex Plain
18	57-110-A	1	Hair Pin	58	69-416-24	1	Bolt 1/4-20x1 $\frac{1}{2}$ Contour Hd.
19	82-23-B	1	Shifter Rod	59	80-162-A	1	Shifter Spring
20	80-254-A	1	Control Arm Assy.	60	82-17-A	1	Spacer
21	365-516	3	Nut, 1/4-20 Hex Lock	61	515-516-12	1	Screw
22	945-416	10	Washer 1/4 Flat	62	65-416-8	5	Hex Bolt 1/4-20x1/2
23	75-10-A	1	Spacer	64	364-616	1	Locknut, 3/8-16
24	74-95-D	1	Shift Control Bracket	65	80-181-A	1	Clamp
25	75-89-A	2	Speed Nut	66	66-431-A	2	Washer
26	60-416-10	1	Bolt, 1/4-28x5/8 Hex. Hed.	67	81-42-A	2	Spacer
27	365-616	5	Nut, 3/8-16 Hex. Lock	68	SA-968-A	1	Tensioner-Chain
28	80-225-A	1	Speed Control Link 80-264-A	69	65-516-10	2	Bolt 5/16-18x5/8 Hex. Hd.
29	SA-851-B	1	Shifter Linkage Weldment	71	65-616-20	1	Bolt 3/8-16 Hex. Hd.
30	SA-857-A	1	Transmission	72	82-19-B	1	Adj. Plate Weldment
31	48-277-A	2	Key, 3/16 Square	73	80-44-A	2	Clevis Pin
32	65-516-12	14	Bolt, 5/16-18x3/4	74	380-332-8	2	Cotter Pin
33	82-20-C	1	Transmission Bracket Brace	75	80-32-A	1	Bracket & Nut Weldment
34	365-516	14	Nut 5/16-18 Hex. Lock	76	65-616-16	7	Bolt 3/8-16-1 Hex. Hd.
35	82-15-D	1	Transmission Bracket	77	945-616	5	Washer 3/8 Flat
36	74-114-A	1	Flexible Coupline	78	81-44-A	1	Nylon Pulley
37	81-83-D	1	Shaft Guard	79	81-45-A	1	Spacer
38	935-516	8	Lockwasher, 5/16 Spring	80	81-31-A	1	Spring
39	65-516-16	7	Bolt, 5/16-18x1 Hex. Hd.	81	61-516-12	2	Bolt 5/16-18x3/4 Self Tapping
40	SA-817-B	2	Bearing Assy. Modification	82	935-616	3	Lockwasher 3/8 Spring
41	74-100-C	1	Sprocket Differential, 40 Teeth				



AF-280

HANDLE ASSEMBLY

PARTS LIST

Ref. No.	Part No.	Description	Qty.		Ref. No.	Part No.	Description	Qty.	
			Per Unit	SP LP				Per Unit	SP LP
1	SA-733-D	Dust Bag Assembly <i>MA-419-1</i>	1	1	30	81-57-A	Clutch Grip Assembly <i>SA-1176-A</i>	1	1
2	SA-794-B	Strap Assembly	1	1	31	50-230-A	Washer - Special	2	2
3	63-304-A	Bag Hook	2	2	32	78-130-A	Bearing, Caster	2	2
4	80-232-A	Handle Grip	2	2	33	SA-962- B	Caster Assembly	2	2
5	81-11-C	Handles	1	1	34	69-516-16	Bolt 5/16-18x1 Contour	2	2
6	69-416-24	Bolt, 1/4-20x1½ Contour Hd.	15	15	35	935-616	Split Lockwasher	2	2
7	335-516	Nut, Hex Plain 5/16-18	4	4	36	936-616	Int. Tooth Lockwasher	2	2
8	81-04-B	Cross Brace, Upper	1	1	37	SA-928-A	Stop Switch Assy.	1	1
9	82-13-B	Trus Brace	2	2	38	81-21-A	Switch Wire <i>83-27-B-53</i>	1	1
10	81-58-B	Cross Brace, Lower	1	1	39	515-10-8	Screw 10-24-1/2 Rd. Hd.	2	2
11	65-516-32	Bolt, 5/16-18x2, Contour <i>HEX</i> Hd.	2	2	40	81-22-A	Throttle Control Assy. <i>83-25-B-54</i>	1	1
12	935-416	Lock Washer, 1/4 Spring	15	15	41	365-10	Nut, Hex. Lock	2	2
13	335-416	Nut, 1/4-20, Hex. Plain	15	15	42	65-416-28	Bolt Hex. Hd. 1/4-20x1¾	1	1
14	65-516-28	Bolt, 5/16-18x1¼ Hex. Hd.	2	2	43	80-181-A	Clamp	1	1
15	365-516	Nut, 5/16-18, Hex. Lock	4	4	44	945- 406	Flatwasher 1/4	4	4
16	935-516	Lockwasher 5/16 Spring	4	4	45	80-237-A	Bag Guard	1	1
17	80-276-A	Control Clamp, Snap	2	2	46	80-267-A	Plastic Tube Cape	2	2
18	365-8	Nut, Hex Lock 8-32	2	2	47	81-88-A	Wire Clamp	2	2
19	945-516	Flatwasher 5/16	10	10	48	515-8-8	Screw, Rd. Hd. 8-32-½	2	2
20	80-238-A	Handle Inserts	6	6	49	365-416	Hex. Lock Nut 1/4-20	1	1
21	80-225-A	Spacer <i>80-269-A</i>	1	1	50	76-36-A	Special Washer	4	4
22	80-246-B	Pivot Bracket	2	2	51	81-116-A	Tubing End Cap	2	2
23	80-228-A	Knurled Torque Knob	2	2	52	81-120-A	Spacer	2	2
24	69-516-28	Contour Bolt 5/16-18x1¾	2	2	53	82-84-A	Clutch Cable	1	1
25	81-53-B	Middle Handle	2	2	54	81-23-C	Upper Handle, RH	1	1
	SA-873-C	Bag Platform	1	1	55	74-167-A	Spring	1	1
27	80-235-C	Bag Platform	1	1					
28	81-96-C	Frame, Bag Platform	1	1					
29	82-02-B	Caster Plate	2	2					

KOHLER ENGINE ASSEMBLY

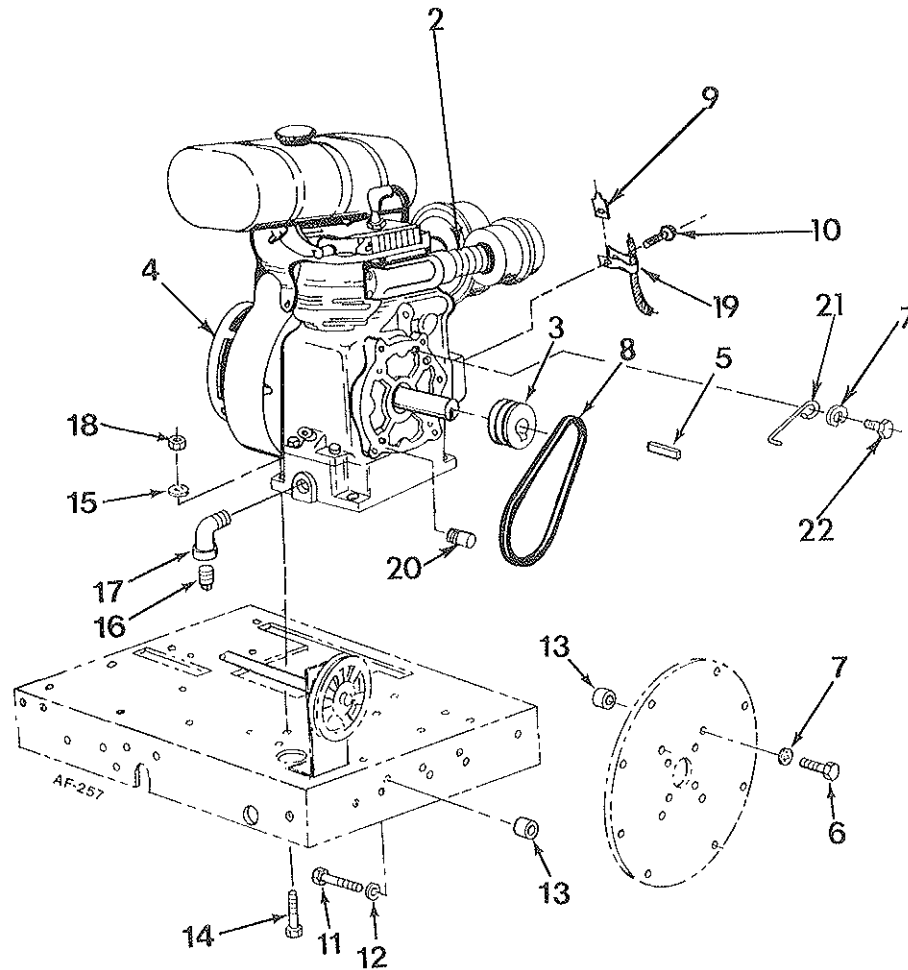

PARTS LIST

Ref. Part No. No.	Description	Quantity Per Unit		Ref. Part No. No.	Description	Quantity Per Unit	
		SP	SP-LP			SP	SP-LP
1	Engine Assembly	-	-	12 935-416	Lockwasher ¼"	2	2
2 67-68-A	Pipe Nipple 1 x 4	1	1	13 79-139-A	Spacer, Back Cover	6	6
3 81-61-A	Pulley, Engine	1	1	14 65-616-20	Bolt, ⅜-16 x 1¼ Hex. Hd.	4	4
4 78-121-A	Engine, Kohler	1	1	15 945-616	Flat Washer, ⅜"	4	4
5 74-112-A	Fan Key ¼ x 2½	1	1	16 **	Pipe Plug, Oil Drain	1	1
6 65-616-24	Bolt, ⅜-16 x 1½ Hex. Hd.	4	4	17 57-81-A	Street Elbow ½ x 90°	1	1
7 935-616	Lock Washer, ⅜ Spring	5	5	18 365-616	Nut, ⅜-16, Hex. Hd. Lock	4	4
8 73-417-A	V Belt 3L-210	1	1	19 75-115-A	Throttle Cable Clip	1	1
9 66-96-A	Speed Nut 10-24 U-Type	1	1	20 81-32-A	Belt Popper	1	1
10 515-10-8	Screw 10-24 x ½ Rd. Hd.	1	1	21 81-33-A	Belt Popper	1	1
11 65-416-28	Bolt, ¼-20 x 1¾ Hex. Hd.	2	2	22 65-616-12	Bolt, Hex. Hd. 3/8-16x3/4	1	1

L.P. GAS GROUP

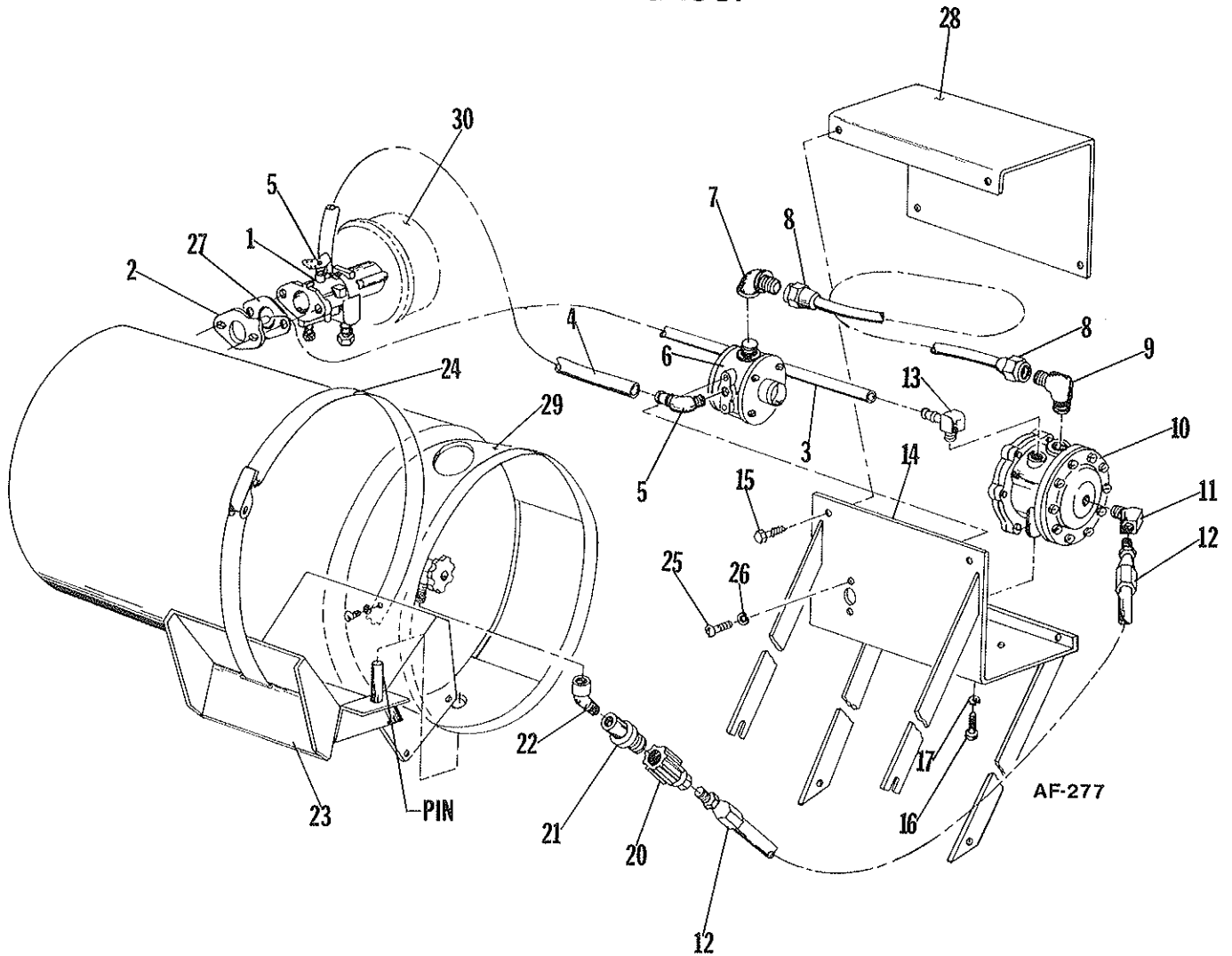

PARTS LIST

Ref. No.	Part No.	Description	Qty. Per Unit	Ref. No.	Part No.	Description	Qty. Per Unit
1	80-114-A	Carburetor	1	15	62-416-10	Bolt, Tapping, 1/4-28 x 3/8, Hex Hd.	4
2	80-121-A	Idler Plate	1	16	65-416-12	Bolt, 1/4-20 x 3/4, Hex Hd.	2
3	80-153-A	Line, Vacuum (Tube Only)	1	17	935-416	Lock Washer, 1/4 Spring	2
4	80-154-A	Fuel Line, Carb	1	20	62-252-A	Connector, Safety, Female	1
5	75-19-A	Hose Barb, 90°	2	21	62-253-A	Connector, Safety, Male	1
6	74-145-A	Pressure Regulator	1	22	73-234-A	Street Elbow, 3/8 x 45°	1
7	80-111-A	Elbow, Female	1	23	65-565-C	Bracket, Weldment, Tank	1
8	80-115-A	Fuel Line, Transfer Assembly	1	24	65-751-A	Band, Tank Holddown 80-278-B	1
9	80-113-A	Elbow, Male	1	25	515-8-8	Screw, 8-32 x 1/2, Rd. Hd.	2
10	72-228-A	Fuelock, Vacuum & Filter	1	26	935-8	Lock Washer, #8, Spring	2
11	75-18-A	Street Elbow, 1/4 x 45°	1	27	*210223	Gasket	2
12	74-152-A	Fuel Line, Inlet Assembly	1	28	76-365-C	Cover, Regulator Mount	1
13	80-112-A	Elbow, Male (W/Nut & Sleeve)	1	29	67-69-B	Tank 14 Lb.	1
14	74-142-C	Bracket, Weldment	1	29	65-747-B	Tank 20 Lb.	1
				30	*231847	Air Cleaner	1

* Kohler Engines Part No.

HOUSING UNIT ASSEMBLY

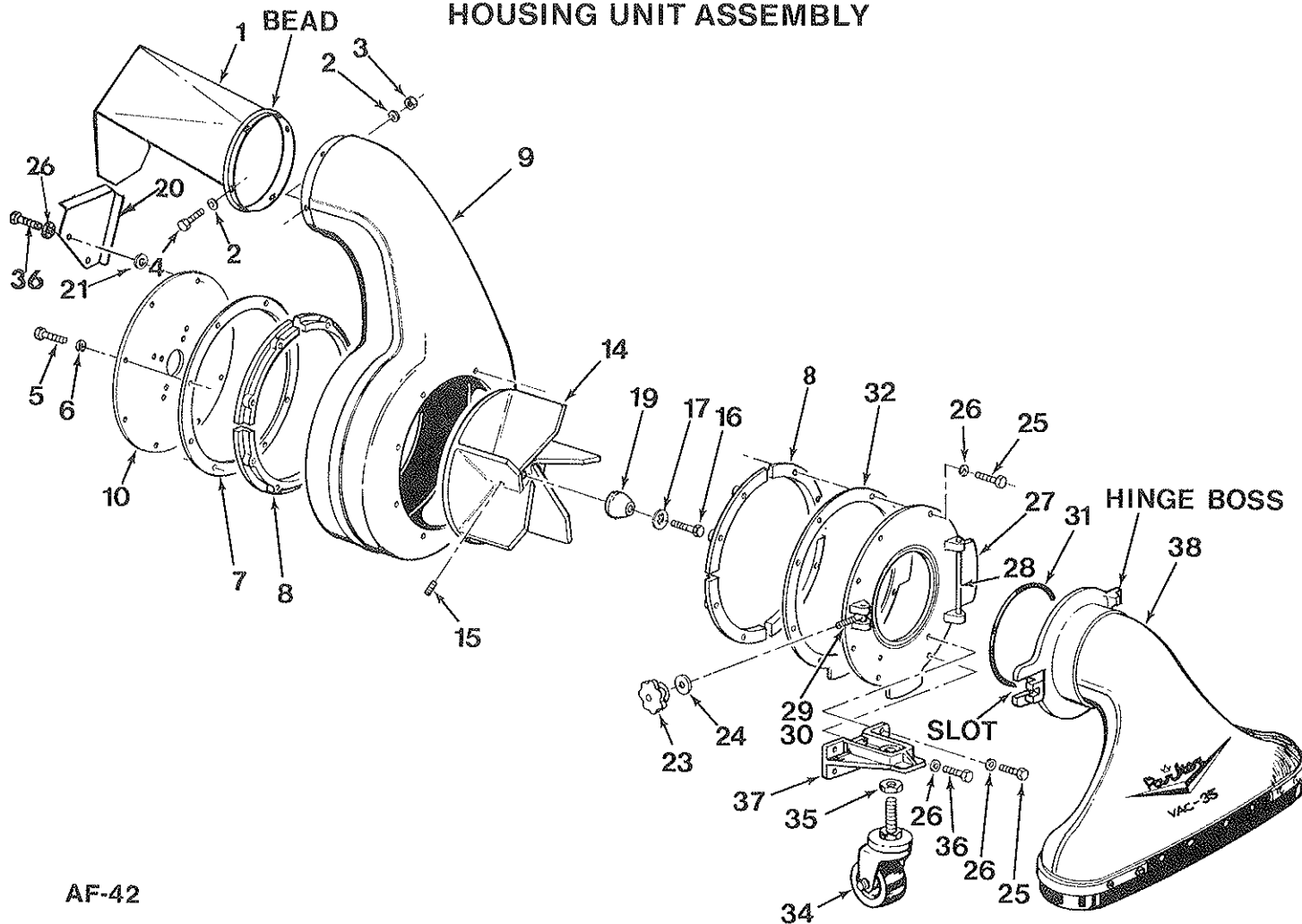

AF-42

PARTS LIST

Ref. No.	Part No.	Description	Quantity Per Unit SP	Ref. No.	Part No.	Description	Quantity Per Unit SP
1	68-308-B	Spin Pak, Deflector Weld.	1	24	945-816	Flat Washer, 1/2 SAE	1
2	945-416	Flat Washer, 1/4 SAE	8	25	65-416-16	Bolt, 1/4-20 x 1, Hex Head	6
3	364-416	Nut 1/4-20, Hex Hd., Lock, Thin	4	26	935-416	Lock Washer, 1/4 Spring	10
4	65-416-10	Bolt, 1/4-20 x 3/8, Hex Hd.	4	27	63-191-D	Front Cover SA-1389-D	1
5	65-416-16	Bolt, 1/4-20 x 1 Hex Hd.	4	28	63-194-A	Hinge Pin	1
6	935-416	Lock Washer, 1/4 Spring	6	29	63-192-A	Pivot Bolt	1
7	62-187-C	Rubber Gasket	1	30	63-193-A	Roll Pin, 0.264 x 1 3/4	1
8	64-78-C	Anti-Wrap Segment	8	31	63-190-A	O-Ring, Gasket	1
9	70-103-F	Housing Assembly	1	32	75-03-C	Gasket, Front	1
10	73-430-C	Back Cover	1	34	64-71-A	Caster Stem Type	1
14	72-175-D	Fan Wheel	1	35	340-1216	Nut, 3/4-10, Hex. Jam	1
15	564-516-16	Setscrew	1	36	65-416-20	Bolt, 1/4-20 x 1 1/4, Hex. Hd.	4
16	65-39-A	Bolt, 7/16-20 x 2 1/2, Hex Hd.	1	37	66-430-C	Caster Bracket	1
17	936-716	Lock Washer, 7/16 Spring	1	38	SA-911-D	Intake Housing, 30" MA-251-D	1
19	73-119-A-3	Fan Retainer	1	38	MA-113-D	Intake Housing, 24"	*
20	72-241-B	Heat Shield	1	38	MA-120-D	Intake Housing, 36"	*
21	54-227-A	Spacer	2				
23	80-29-A	Adjusting Knob	1				

*Purchased separate, optional accessory

PEERLESS "750"-A TRANSMISSION

PARTS LIST

Ref. No.	Part No.	Description
1	770061	Case, Transmission
2	772083	Cover, Transmission
3	776161	Shaft, Output & Brake
4	778121A	Gear, Spur (20 teeth)
5	778122A	Gear, Spur (22 teeth)
6	778123A	Gear, Spur (25 teeth)
7	778124A	Gear, Spur (30 teeth)
8	778125	Gear, Spur (35 teeth)
9	784266	Collar, Shift
10	786060	Sprocket (14 teeth)
11	786061	Sprocket (10 teeth)
12	776134	Shaft, Counter
13	778109	Gear, Bevel (42 tooth & 15 tooth spur gear)
14	778126A	Gear, Spur (20 teeth)
15	778127A	Gear, Spur (25 teeth)
16	778128A	Gear, Spur (28 teeth)
17	778129A	Gear, Spur (30 teeth)
18	776135	Shaft, Input
19	778113A	Bevel Pinion, Input
20	786047	Sprocket (8 teeth)
21	790003	Disk, Brake
22	790013	Lever, Brake
23	790025	Holder, Brake pad
24	790006	Pad, Brake
25	790007	Plate, Brake pad
26	786026	Pin, Dowel
27	780105A	Bushing, Flanged
28	786062	Chain, Roller (No. 41 chain, 22 links)
29	780072	Washer, Thrust
30	780086	Bearing, Needle
31	792072	Ring, Retaining
32	792035	Ring, Retaining
33	780109	Washer
34	788040	Ring, Retaining
35	784267	Rod & Fork Assy., Shift
36	792073	Screw, Hex. Hd. Taptite, 1/4-20x2¼
37	792089A	Key
38	792075	Nut, Lock, 5/16-24
39	792076	Washer, Flat, 5/16
40	792077	Ball, Steel, 5/16"
41	792078	Screw, Set, 3/8-16x3/8
42	792079	Spring
43	780108	Washer, Thrust
44	792001	"O" Ring
45	792074	Plug
46	788054	Gasket
47	786046	Bracket

PEERLESS TRANSMISSION

MODEL 750-A

Five Speed

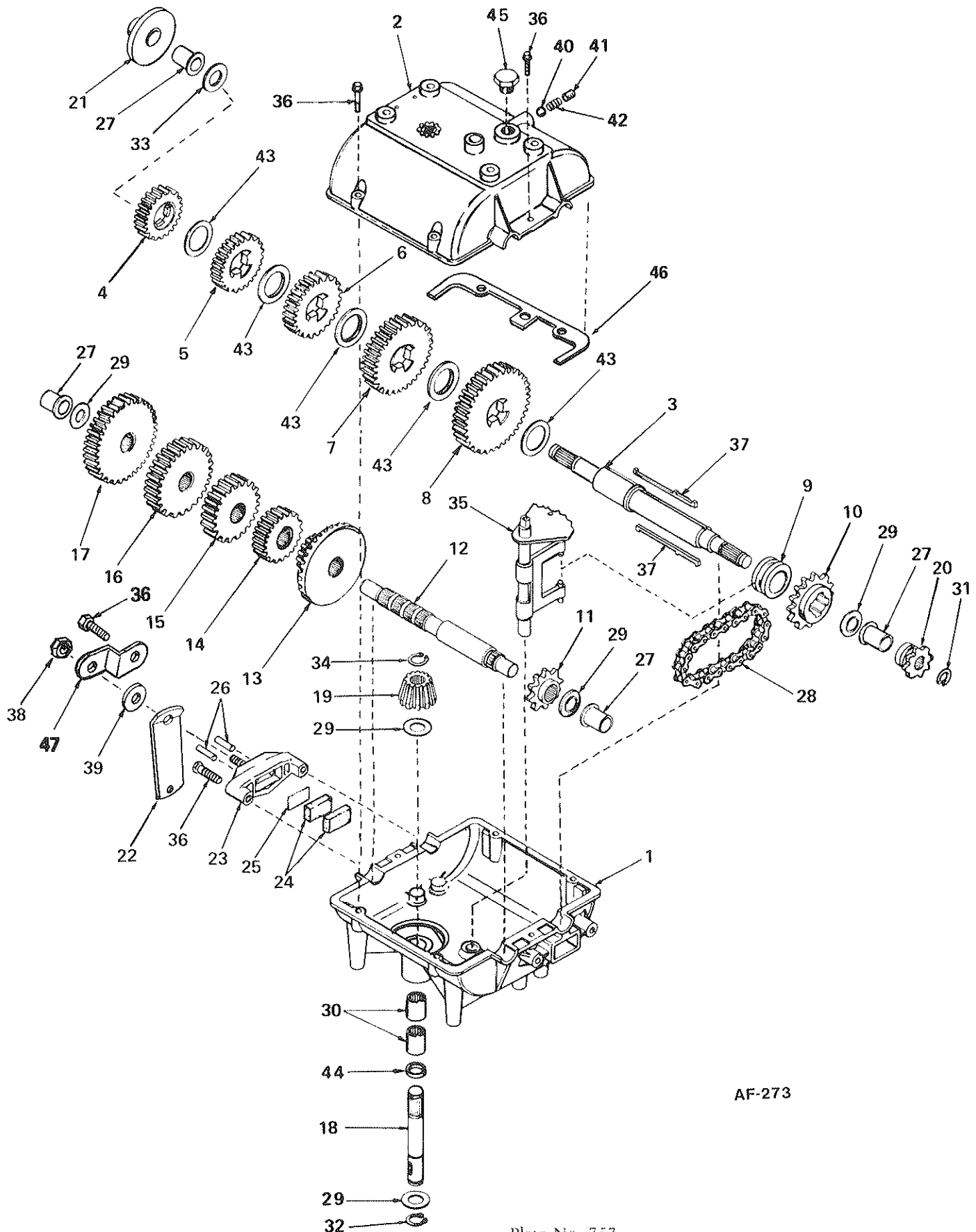

AF-273

