

# VACUUM SWEEPER

## VAC-35 SELF-PROPELLED

SECTION 11

MODEL PV-7706-SP

MODEL PV-7706-SP-LP

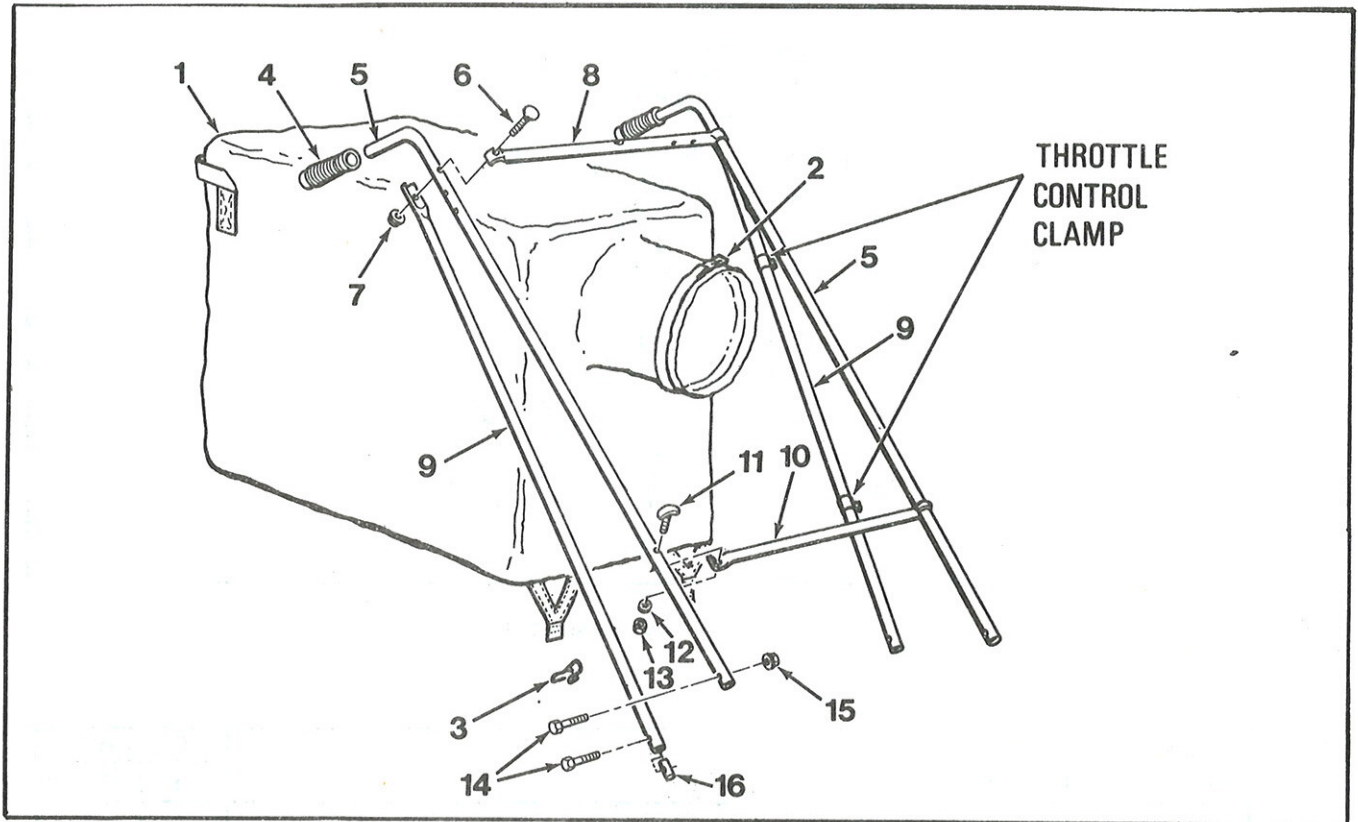

Handle Bar

INDEX NO.	PART NO.	DESCRIPTION	PV-7706	
			-SP	-SP-LP
1	68-307-F	• DUST BAG ASSEMBLY <i>MA-419-1..350800</i> .....	1	1
2	63-274-A	• STRAP ASSEMBLY SA-794-B.....	1	1
3	63-304-A	• BAG HOOK .....	2	2
	<del>SA-536-C</del>	HANDLE ASSEMBLY .....	1	1
4	76-67-A	• HANDLE GRIP - RED .....	2	2
5	76-236-B	• HANDLE .....	2	2
6	65-416-24	• BOLT, 1/4-20x1-1/2 HEX HD .....	2	2
7	364-416	• NUT, 1/4-20 HEX LOCK .....	2	2
8	76-170-B	• CROSS BRACE, UPPER .....	1	1
9	76-238-B	• TRUSS BRACE .....	2	2
10	76-173-B	• CROSS BRACE, LOWER .....	1	1
11	69-416-24	• BOLT, 1/4-20x1-1/2 CONTOUR HD .....	2	2
12	935-416	• LOCK WASHER, 1/4 SPRING .....	4	4
13	335-416	• NUT, 1/4-20, HEX PLAIN .....	2	2
14	65-516-24	• BOLT, 5/16-18x1-1/2 HEX HD .....	4	4
15	365-516	• NUT, 5/16-18, HEX LOCK .....	4	4
16	76-178-A	• TUBE INSERT .....	4	4

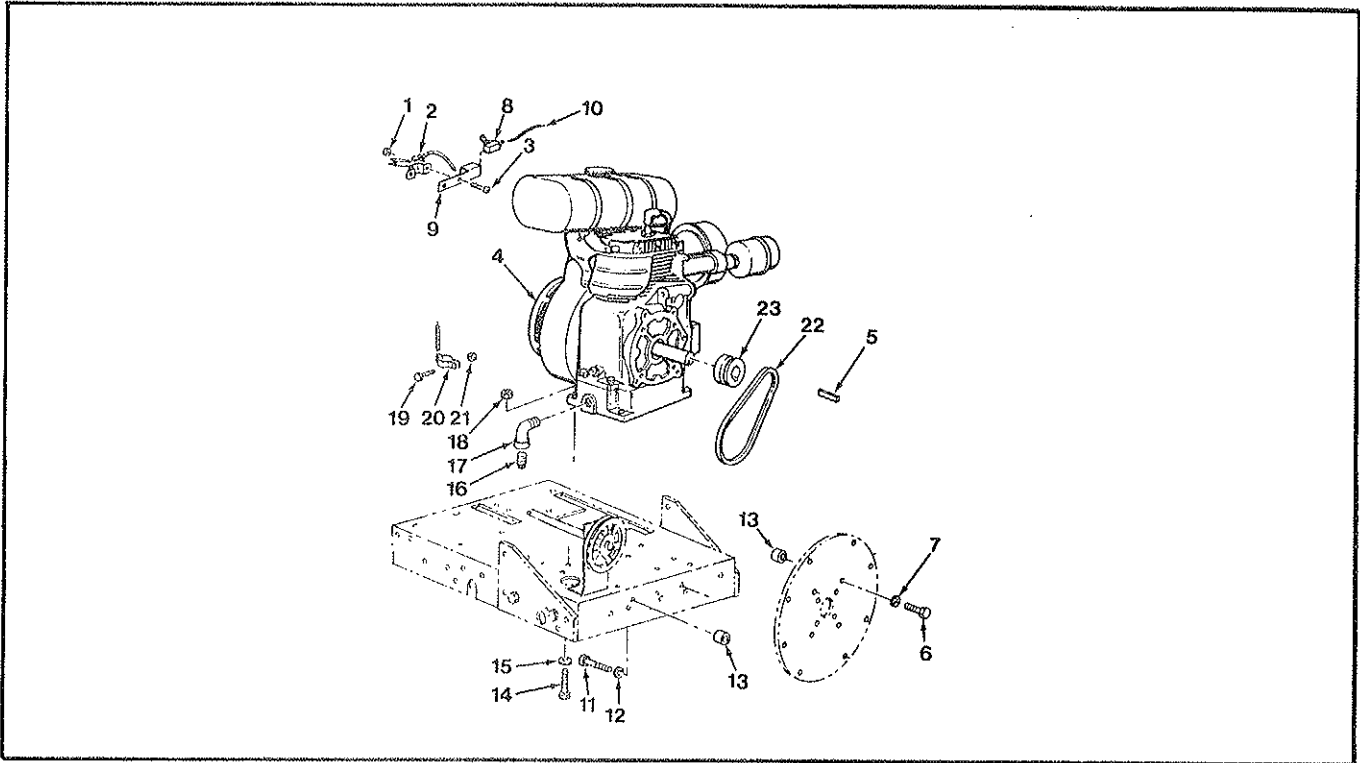

Engine Assembly

INDEX NO.	PART NO.	DESCRIPTION	PV-7706	
			-SP	-SP-LP
1	365-10	NUT, 10-24 HEX LOCK	4	4
2	<del>68-393-A</del>	THROTTLE CONTROL ASSEMBLY <del>83-25-B-65</del>	1	1
3	517-10-18	SCREW, 10-24x1-1/8 OVAL HD	2	2
4	<del>65-34-A</del>	ENGINE, KOHLER	1	-
4	65-550-A	ENGINE, KOHLER LP	-	1
5	74-112-A	FAN KEY 1/4x2-3/8	1	1
6	65-616-24	BOLT, 3/8-16x1-1/2 HEX HD	4	4
7	935-616	LOCK WASHER, 3/8 SPRING	3	3
8	75-91-A	SWITCH, SAFETY STOP	1	1
9	75-77-B	BRACKET	1	1
10	<del>95-97-A</del>	LEAD, WIRE ASSEMBLY, ELECTRIC <del>83-27-B-62</del>	1	1
11	65-416-28	BOLT, 1/4-20x1-3/4 HEX HD	2	2
12	935-416	LOCK WASHER, 1/4 SPRING	2	2
13	73-414-A	SPACER, BACK COVER	6	6
14	65-616-20	BOLT, 3/8-16x1-1/4, HEX HD	4	4
15	945-616	FLAT WASHER, 3/8	4	4
16	**	PIPE PLUG, OIL DRAIN	1	1
17	57-81-A	STREET ELBOW 1/2x90°	1	1
18	365-616	NUT, 3/8-16, HEX HD, LOCK	4	4
19	515-8-8	SCREW, 8-32x1/2, RD HD	2	2
20	76-179-A	CONTROL CLAMP	2	2
21	365-8	NUT, 8-32, HEX LOCK	2	2
22	73-417-A	V BELT, 3L-210	1	1
23	74-119-A	PULLEY, ENGINE	1	1
**	SUPPLIED WITH ENGINE			

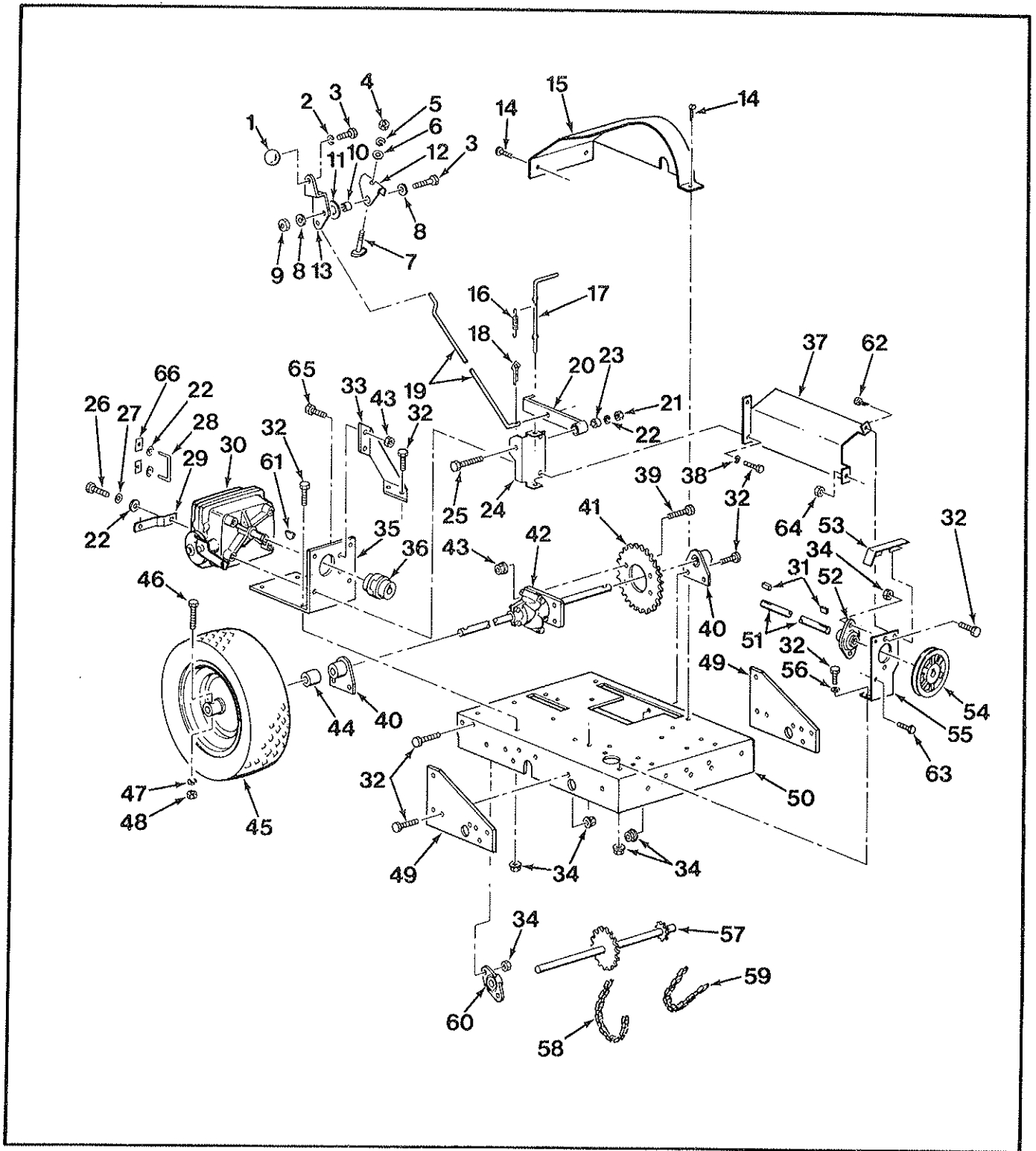

Chassis and Drive Components

INDEX NO.	PART NO.	DESCRIPTION	PV-7706	
			-SP	-SP-LP
1	55-130-A	KNOB, BALL	1	1
2	935-516	LOCK WASHER, 5/16 SPRING	2	2
3	65-516-12	BOLT, 5/16-18x3/4 HEX HD	2	2
4	335-416	NUT, 1/4-20 HEX PLAIN	1	1
5	935-416	LOCK WASHER 1/4 SPRING	2	2
6	945-416	WASHER, 1/4 FLAT	2	2
7	69-416-24	BOLT, 1/4-20x1-1/2 CONTOUR HD	1	1
8	945-516	WASHER, 5/16 FLAT	4	4
9	364-516	NUT, 5/16-18 HEX LOCK THIN	1	1
10	<del>59-29-A</del>	SPACER	1	1
11	946-816-16	WASHER, FIBER	1	1
12	76-176-A	BRACKET	1	1
13	70-67-A	LEVER, SHIFT	1	1
14	65-416-8	BOLT, 1/4-20x1/2 HEX HD	3	3
15	<del>74-171-D</del>	GUARD, CHAIN <i>82-195-D</i>	1	1
16	74-167-A	SPRING, BRAKE	1	1
17	<del>74-36-A</del>	LEVER, BRAKE	1	1
18	380-332-12	PIN, COTTER	1	1
19	74-107-A	ROD, SPEED CONTROL	1	1
20	75-12-A	CONTROL ARM ASSEMBLY, SHIFT	1	1
21	365-416	NUT, 1/4-20 HEX LOCK	4	4
22	945-416	WASHER, 1/4 FLAT	5	5
23	75-10-A	SPACER	1	1
24	74-95-D	BRACKET, SHIFT CONTROL	1	1
25	65-416-28	BOLT, 1/4-20x1-3/4	1	1
26	60-416-10	BOLT, 1/4-28x5/8 HEX HD	1	1
27	935-416	LOCK WASHER, 1/4 SPRING	1	1
28	74-97-A	LINK, SPEED CONTROL	1	1
29	74-106-A	LEVER, TRANSMISSION	1	1
30	<del>SA-458-A</del>	TRANSMISSION, MECHANICAL	1	1
31	48-277-A	KEY, 3/16 SQUARE	2	2
32	65-516-12	BOLT, 5/16-18x3/4 HEX HD	24	24
33	74-94-B	BRACE, TRANSMISSION BRACKET	1	1
34	365-516	NUT, 5/16-18 HEX LOCK	20	20
35	74-93-C	BRACKET, TRANSMISSION	1	1
36	74-114-A	COUPLING, FLEXIBLE	1	1
37	75-95-C	GUARD, SHAFT	1	1
38	935-516	LOCKWASHER, 5/16 SPRING	4	4
39	65-516-16	BOLT, 5/16-18x1. HEX HD	4	4
40	74-102-A	BRACKET, BEARING	2	2
41	74-100-C	SPROCKET, DIFFERENTIAL, 40 TEETH	1	1
42	<del>SA-459-B</del>	DIFFERENTIAL ASSEMBLY <i>MA-588-C</i>	1	1
43	364-516	NUT, 5/16-18 HEX LOCK THIN	8	8
44	74-105-A	BEARING	2	2
45	68-310-B	WHEEL ASSEMBLY	2	2

INDEX NO.	PART NO.	DESCRIPTION	PV-7706	
			-SP	-SP-LP
	68-311-B	• WHEEL	2	2
	68-312-A	• TIRE 5.10/4.50x6	2	2
	68-313-A	• VALVE STEM	2	2
46	65-416-24	BOLT, 1/4-20x1-1/2 HEX HD	2	2
47	935-416	LOCKWASHER, 1/4 SPRING	2	2
48	335-416	NUT, 1/4-20 HEX PLAIN	2	2
49	73-362-C	BRACKET, HANDLE	2	2
50	74-99-D	CHASSIS	1	1
51	74-88-A	DRIVE SHAFT	1	1
52	66-41-A	BEARING, SEAL MASTER	1	1
53	75-94-B	GUARD, BELT	1	1
54	74-86-A	SHEAVE, DRIVE	1	1
55	74-87-C	BRACKET, BEARING	1	1
56	945-516	WASHER, 5/16 FLAT	2	2
57	74-89-B	JACK SHAFT WELDMENT	1	1
58	74-117-A	CHAIN, ROLLER, # 41-32P TRANSMISSION TO JACKSHAFT	1	1 84-41-32-B
59	74-118-A	CHAIN, ROLLER, # 41-50P JACKSHAFT TO DIFFERENTIAL	1	1 84-41-50-B
60	74-116-A	BEARING ASSEMBLY, SIDE FLANGE	2	2
61	280-09	#9 WOODRUFF KEY	1	1
62	530-7-6	SCREW # 7x3/8 TYPE A SHEET METAL	2	2
63	515-10-6	SCREW # 10-24x3/8 RD HD MACH	2	2
64	365-10	NUT # 10-24 HEX LOCK	1	1
65	65-516-10	BOLT, HEX HD. 5/16-18 x 5/8	2	2
66	75-89-A	Speed Nut	2	2

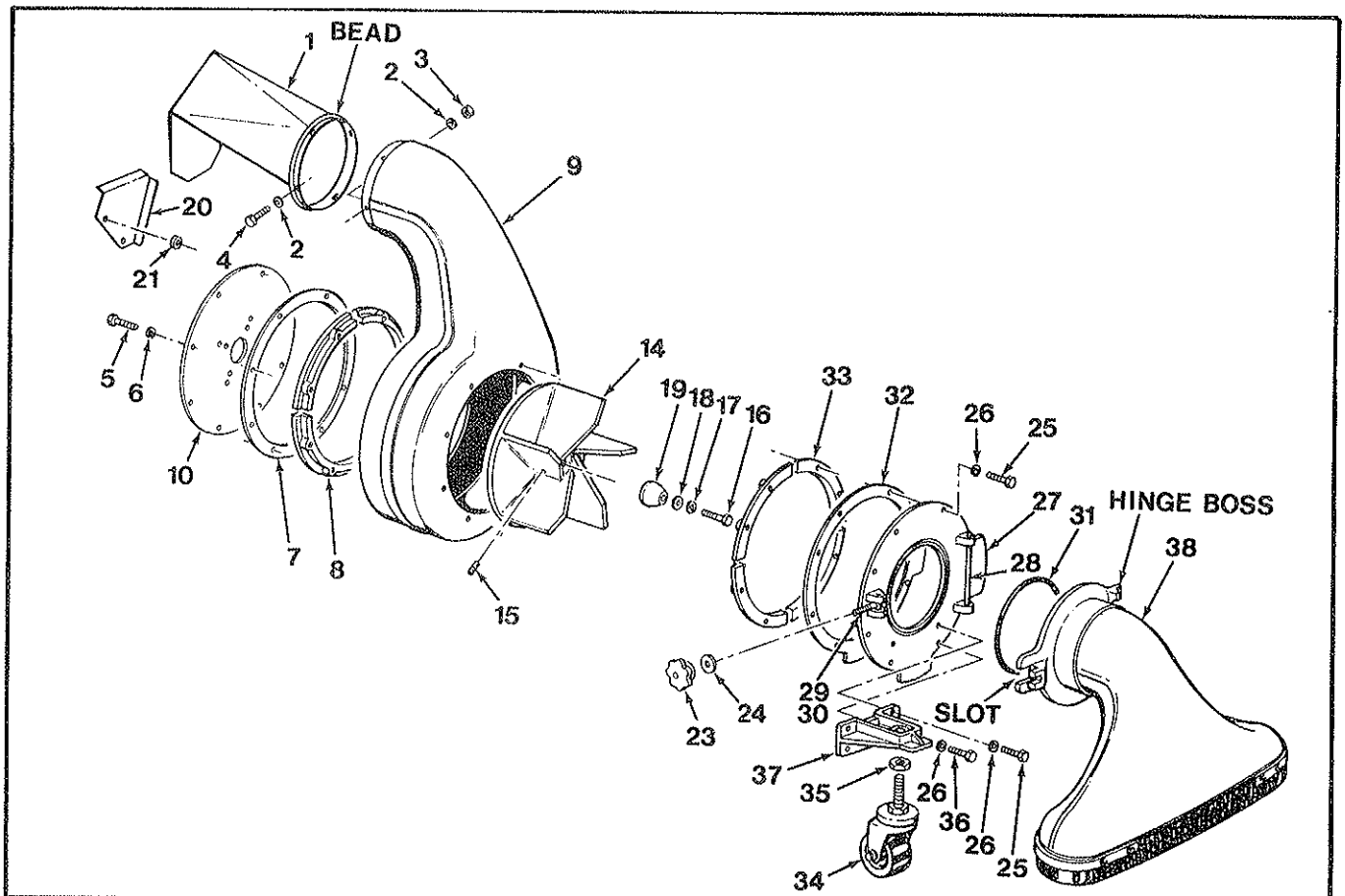

Fan Housing Components

INDEX NO.	PART NO.	DESCRIPTION	PV-7706	
			-SP	-SP-LP
1	<del>68-308-B</del>	SPIN PAK, DEFLECTOR WELDMENT <i>SA-1413-C</i> . . . . .	1	1
2	945-416	FLAT WASHER, 1/4 SAE . . . . .	8	8
3	364-416	NUT, 1/4-20, HEX HD, LOCK, THIN . . . . .	4	4
4	65-416-10	BOLT, 1/4-20x5/8, HEX HD . . . . .	4	4
5	65-416-16	BOLT, 1/4-20x1, HEX HD . . . . .	6	6
6	935-416	LOCK WASHER, 1/4 SPRING . . . . .	6	6
7	62-187-C	RUBBER GASKET . . . . .	1	1
8	64-78-C	ANTI-WRAP SEGMENT . . . . .	4	4
9	70-103-F	HOUSING ASSEMBLY . . . . .	1	1
10	73-430-C	BACK COVER . . . . .	1	1
14	72-175-D	FAN WHEEL . . . . .	1	1
15	<del>664-516-16</del>	• SETSCREW . . . . .	1	1
16	<del>65-39-A</del>	BOLT, 7/16-20x2-1/2, HEX HD <i>60-716-40</i> . . . . .	1	1
17	935-716	LOCK WASHER, 7/16 SPRING . . . . .	1	1
19	<del>73-119-A</del>	FAN RETAINER <i>82-138-B-3; 60-716-16; 935-716</i> . . . . .	1	1
20	72-241-B	HEAT SHIELD . . . . .	1	1
21	54-227-A	SPACER . . . . .	2	2
23	<del>59-47-BB-2</del>	ADJUSTING KNOB . . . . .	1	1
24	945-816	FLAT WASHER, 1/2 SAE . . . . .	1	1
25	65-416-16	BOLT, 1/4-20x1, HEX HD . . . . .	8	8
26	935-416	LOCK WASHER, 1/4 SPRING . . . . .	10	10
27	<del>63-191-D</del>	FRONT COVER <i>SA-1389-D</i> . . . . .	1	1
28	63-194-A	HINGE PIN . . . . .	1	1
29	63-192-A	PIVOT BOLT . . . . .	1	1
30	63-193-A	ROLL PIN, 0.264x1-3/4 . . . . .	1	1
31	63-190-A	O-RING, GASKET . . . . .	1	1
32	75-03-C	GASKET, FRONT . . . . .	1	1
33	64-78-C	ANTI-WRAP SEGMENT . . . . .	4	4
34	64-71-A	CASTER STEM TYPE . . . . .	1	1
35	340-1216	NUT, 3/4-10, HEX HD, JAM . . . . .	1	1
36	65-416-20	BOLT, 1/4-20x1-1/4, HEX HD . . . . .	2	2
37	66-430-C	CASTER BRACKET . . . . .	1	1
38	MA-113-D	INTAKE HOUSING, 24 INCH . . . . .	*	*
38	MA-251-D	INTAKE HOUSING, 30 INCH . . . . .	*	*
38	MA-120-D	INTAKE HOUSING, 36 INCH . . . . .	*	*

\*PURCHASED SEPARATE, OPTIONAL ACCESSORY

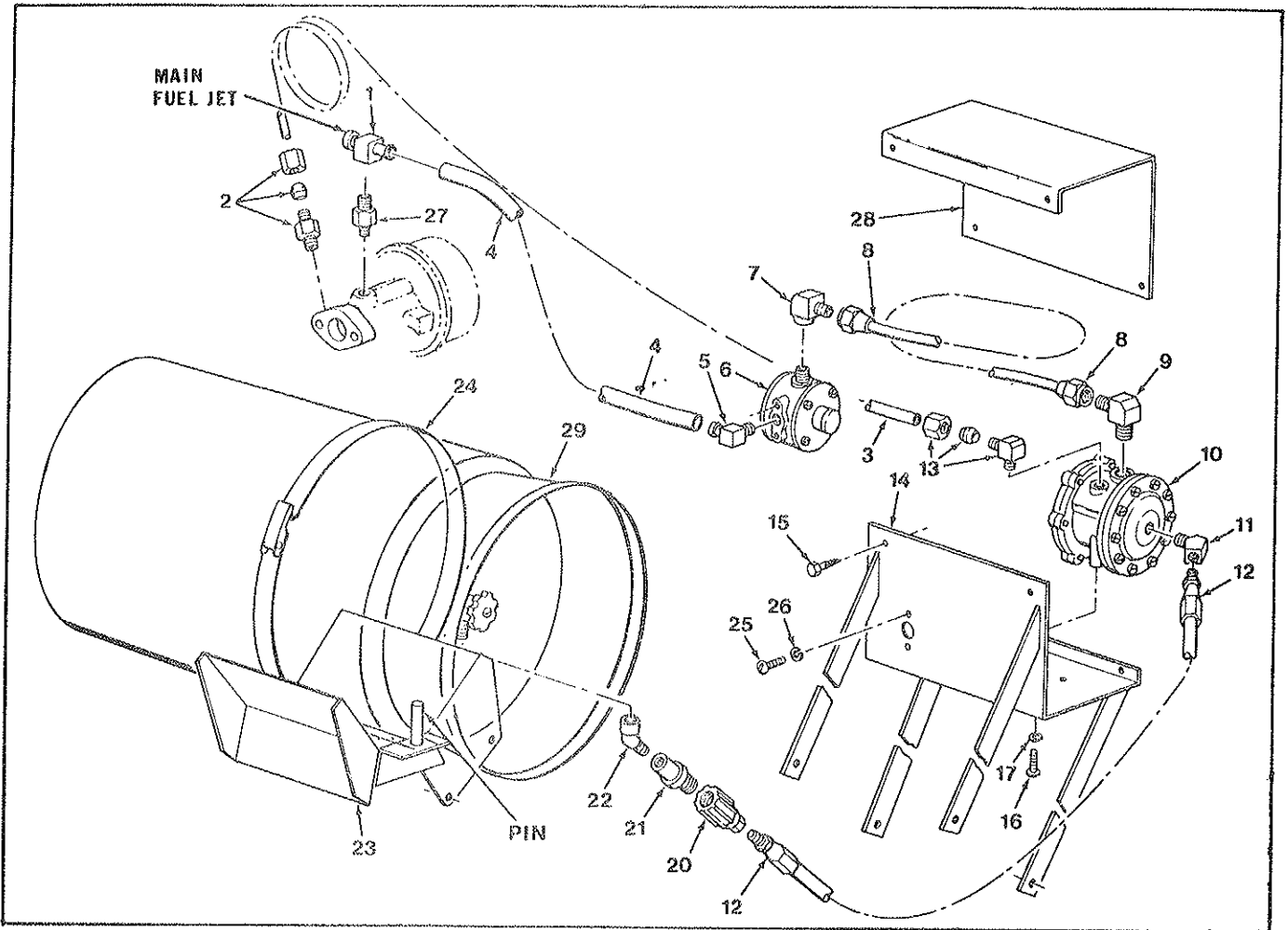

L. P. Gas Group

INDEX NO.	PART NO.	DESCRIPTION	PV-7706-SP-LP
1	73-141-A	LOAD BLOCK	1
2	65-519-A	CONNECTOR, MALE (WITH NUT & SLEEVE)	1
3	75-14-B	LINE, VACUUM (TUBE ONLY)	1
4	74-146-A	FUEL LINE, CARB	1
5	75-19-A	HOSE BARB, 90°	1
6	74-145-A	PRESSURE REGULATOR	1
7	75-16-A	ELBOW, FEMALE	1
8	SA-444-B	FUEL LINE, TRANSFER ASSEMBLY	1
9	75-15-A	ELBOW, MALE	1
10	72-228-A	FUELOCK, VACUUM AND FILTER	1
11	75-18-A	STREET ELBOW, 1/4x45°	1
12	74-152-A	FUEL LINE, INLET ASSEMBLY	1
13	65-518-A	ELBOW, MALE (WITH NUT & SLEEVE)	1
14	72-142-C	BRACKET, WELDMENT	1
15	62-416-10	BOLT, TAPPING, 1/4-28x5/8, HEX HD	4
16	65-416-12	BOLT, 1/4-20x3/4, HEX HD	2
17	935-416	LOCK WASHER, 1/4 SPRING	2
20	62-252-A	CONNECTOR, SAFETY, FEMALE	1
21	62-253-A	CONNECTOR, SAFETY, MALE	1
22	73-234-A	STREET ELL, 45°	1
23	65-565-C	BRACKET, WELDMENT, TANK	1
24	65-751-A	BAND, TANK HOLDDOWN	1
25	518-8-8	SCREW, 8-32x1/2, RD HD	2
26	935-8	LOCK WASHER, # 8, SPRING	2
27	73-142-A	ADAPTER	1
28	74-143-A	COVER, REGULATOR MOUNT	1
29	67-69-B	TANK 14 LB.	1
29	65-747-B	TANK 20 LB.	1

# FOOTE TRANSMISSION MODEL 2600-7 Five Speed

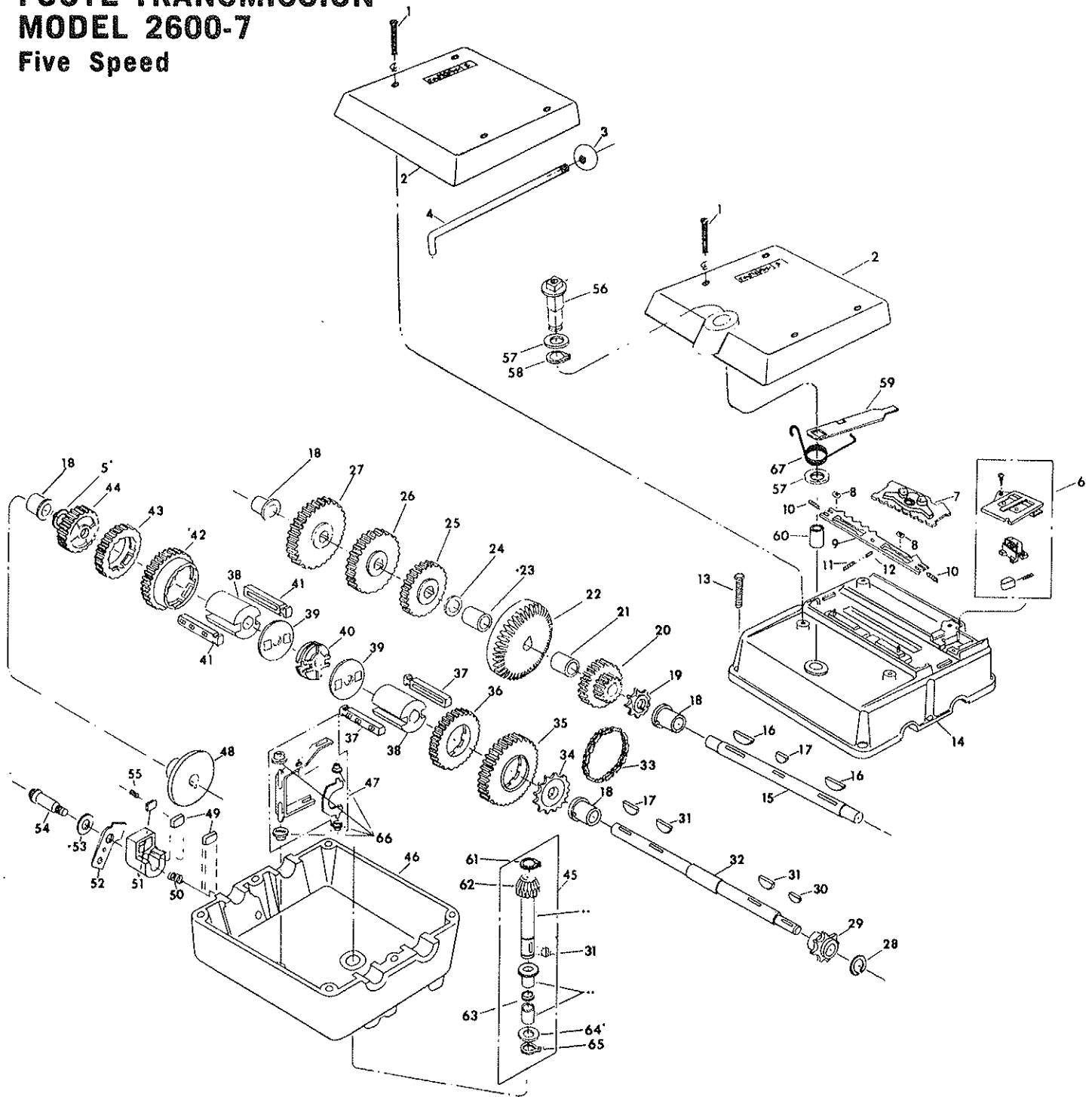

# FOOTE TRANSMISSION MODEL 2600-7

## PARTS LIST

Key No.	Footo Part No.	No. Req'd.	Description	Transmission Models Parts Used On	Key No.	Footo Part No.	No. Req'd.	Description	Transmission Models Parts Used On
1	1879	4	Oval Hd. S.T. Screw (No. 6-32 x 1-1/8)	Models 2600-1, 2600-3, & 2600-4	30	1371	1	No. 4 Woodruff Key	All models
1	1976	4	Oval Hd. S.T. Screw (No. 6-32 x 7/8)	Model 2600-2	31	1374	3	No. 9 Woodruff Key	All models
2	2601	1	Shroud Kit Assembly	Models 2600-1, 2600-3, & 2600-4	32	1883	1	Output Shaft	All models
2	2648	1	Shroud Kit Assembly	Models 2600-1, 2600-3, & 2600-4	32	1990	1	Output Shaft	Model 2600-2
3	1318	1	Shift Knob	Model 2600-1, 2600-3, & 2600-4	33	1090	1	Chain	All models
4	1903	1	Shift Lever	Model 2600-1	34	1889	1	Special 14T Sprocket	All models
4	1978	1	Shift Lever	Model 2600-3	35	1888	1	Spur Gear, 36T	All models
4	1985	1	Shift Lever	Model 2600-4	36	1887	1	Spur Gear, 30T	All models
5	1082	*	Washer, Plain, 1.00 x .630 x .031	All models	37	2621	2	Key Retainer Assembly, R.H.	All models
5	1423	*	Washer, Plain, 1.00 x .630 x .025	All models	38	1890	2	Gear Hub	All models
5	1441	*	Washer, Plain, 1.00 x .630 x .020	All models	39	1891	2	Retaining Washer	All models
5	1708	*	Washer, Plain, 1.00 x .630 x .015	All models	40	1892	1	Clutch Collar	All models
5	1959	*	Washer, Plain, 1.00 x .630 x .010	All models	41	2620	2	Key Retainer Assembly, L.H.	All models
6	2602	1	Switch Kit Assembly	All models	42	1886	1	Spur Gear, 26T.	All models
7	2632	1	Carrier & Lock-out Pawl Assembly	All models	43	1885	1	Spur Gear, 23T.	All models
8	1899	2	Retaining Clip	All models	44	1884	1	Spur Gear, 20T.	All models
9	1908	1	Lock-out Plate	All models	45	2567	1	Input Shaft Kit Assembly	All models
10	1666	2	Compression Spring	All models	46	1864	1	Lower Housing	Model 2600-3
11	1911	1	Detent Spring	All models	46	1864-A	1	Lower Housing	Models 2600-1, & 2600-4
12	1929	1	Detent Pin	All models	46	1864-B	1	Lower Housing	Model 2600-2
13	1919	6	Hx. Hd. S.T. Bolt (1/4-20 x 3/4)	All models	47	2624	1	Shifter Fork Kit Assembly	Models 2600-1, 2600-3, & 2600-4
14	1865	1	Upper Housing	Models 2600-1, 2600-3, & 2600-4	47	2634	1	Shifter Fork Kit Assembly	Model 2600-2
14	1865-A	1	Upper Housing	Model 2600-2	48	1902	1	Brake Disc	All models
15	1868	1	Drive Shaft	All models	49	1767	2	Puck, Friction	All models
16	1878	2	No. 609 Woodruff Key	All models	50	1479	1	Compression Spring	All models
17	1375	1	No. 61 Woodruff Key	Non-brake models	51	2618	1	Brake Jaw Assembly	All models
17	1375	2	No. 61 Woodruff Key	Brake models	52	2272	1	Actuating Lever Assembly	Model 2600-2
18	1101	4	Flange Bearing	All models	52	2315	1	Actuating Lever Assembly	Model 2600-1
19	1874	1	Special 10T Sprocket	All models	53	2665	1	Actuating Lever Assembly	Model 2600-4
20	1873	1	Combination Spur Gear, (14T & 20T)	All models	54	1477	1	Washer, Plain, .750 x .505 x .006	All models
21	1876	1	Spacer	All models	55	1606	1	Shoulder Bolt	All models
22	1877	1	Bevel Gear, 42T	All models	56	1972	1	Set Screw (No. 8-32)	All models
23	1875	1	Spacer	All models	57	1968	2	Pivot Shaft	Model 2600-2
24	1880	*	Washer, Plain, 1.00 x .750 x .020	All models	58	1973	1	Washer, Plain, .615 x .385 x .031	Model 2600-2
24	1881	*	Washer, Plain, 1.00 x .750 x .025	All models	59	1966	1	Retaining Ring	Model 2600-2
24	1882	*	Washer, Plain, 1.00 x .750 x .030	All models	60	1971	1	Actuator	Model 2600-2
24	1954	*	Washer, Plain, 1.00 x .750 x .035	All models	61	1100	1	Sleeve Bearing	Model 2600-2
25	1872	1	Spur Gear, 24T	All models	62	1105	1	Retaining Ring	All models
26	1871	1	Spur Gear, 27T	All models	63	1926	1	16T Bevel Pinion	All models
27	1870	1	Spur Gear, 30T	All models	64	1068	*	O-Ring	All models
28	1300	1	Retaining Ring	All models	64	1082	*	Washer, Plain, 1.00 x .630 x .040	All models
28	1988	1	Retaining Ring	Model 2600-2	64	1145	*	Washer, Plain, 1.00 x .630 x .031	All models
29	1989	1	8T Sprocket	Model 2600-2	64	1358	*	Washer, Plain, 1.00 x .630 x .060	All models
29	1129	1	8T Sprocket	Models 2600-1, 2600-3, & 2600-4	65	1099	1	Washer, Plain, 1.00 x .630 x .050	All models
					66	2661	1	Retaining Ring	All models
					66	2666	1	Pivot Kit Assembly	Model 2600-2
					66	2666	1	Pivot Kit Assembly	Models 2600-1, 2600-3, & 2600-4
					67	1984	1	Torsion Spring	Model 2600-2

NOTE: \* Use in various combinations to maintain proper clearances.  
\*\* Order Key No. 45.

## CROSS REFERENCE Model 2600 Five Speed

Footo transmissions manufactured prior to August, 1974 do not have the model number marked on the unit. For proper part selection it is necessary to know your transmission's model number. The Cross Reference below will aid you in finding that model number.

FOOTE MODEL NO.	YEAR BUILT	CUSTOMER'S NAME	CUSTOMER'S PART NO.
2600-7	1975	Parker Sweeper Co.	SA-458-A

