

- OPERATION
- SERVICE
- PARTS
- CARE



Vac 35[®]
Battery Powered
PV-7201-BP

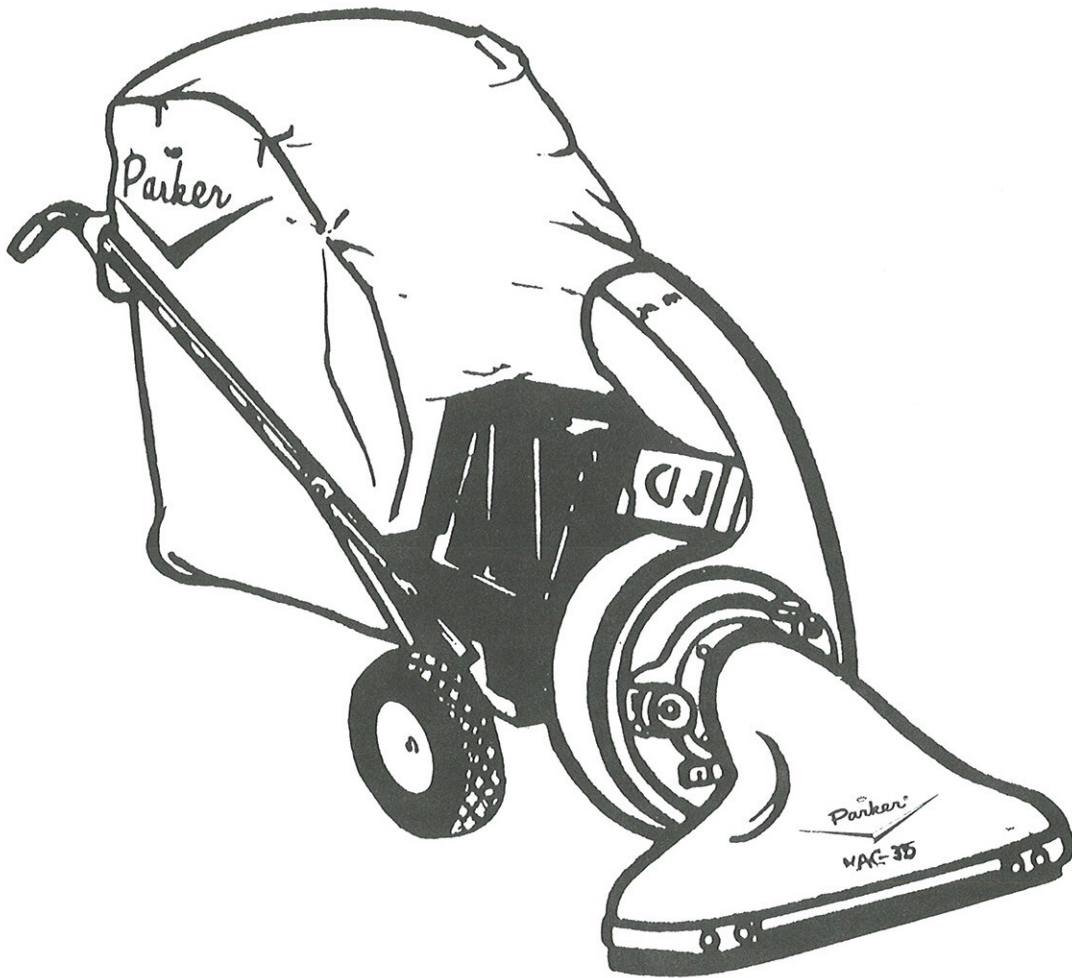

TABLE OF CONTENTS

General Safety Instructions	1 & 2
Warning Decal Placement	3
Assembly & Operation Instructions	4 & 5
Blower Housing Assembly Parts	6
Battery Cabinet Assembly Parts	7
Handle Assembly Parts	8
Electrical Box Assembly	9
Warranty	Back Cover

IMPORTANT SAFETY INSTRUCTIONS

READ ALL INSTRUCTIONS BEFORE USING

WARNING

- To prevent personal injury or property damage, do not attempt to start motor until all assembly steps are complete and you have read and understand the safety and operating instructions in this manual.
- Wear approved safety glasses when operating this equipment. The operation of any powered machine can result in foreign objects being thrown by high-speed rotating parts.
- Wear work gloves, sturdy footwear, and hearing protection when operating this equipment.
- Remove hearing protection and watch for traffic when operating near, or when crossing roadways.
- Do not operate this equipment on a paved, gravel, or hard surface unless the collection bag is installed. Discharged material may bounce from a hard surface.
- Before inspecting or servicing any part of equipment, shut off motor, disconnect batteries and make sure that all moving parts have come to a complete stop. Be aware that rotating blades slow down gradually after motor is shut off.
- Never leave equipment unattended when engine is running. Shut off motor and disconnect batteries before leaving equipment.
- Do not vacuum any burning or smoldering materials such as cigars, cigarettes, ashes or cinders.
- Do not vacuum areas that have been recently treated with fertilizers, pesticides or herbicides. Follow chemical manufacturer's safety instructions regarding contact with treated areas.
- Do not vacuum flammable liquids such as gasoline, kerosene, diesel fuel, paint thinner, etc.

- Never allow children or untrained adults to operate this equipment.
- Keep the area of operation clear of all persons, particularly small children, and pets. Keep bystanders at least 25 feet away from the area of operation.
- Do not allow hands or any other part of the body or clothing inside the vacuum inlet.
- Before removing or installing collection bag, shut off motor.
- Empty the collection bag after each use. Decomposing debris could generate enough heat to catch fire. Before emptying the collection bag, shut off motor and allow all moving parts to come to a complete stop.
- If equipment jams or becomes clogged, immediately shut off motor, disconnect batteries and allow all moving parts to come to a complete stop. Use only a wooden stick to clear away debris.
- Do not operate this equipment with any safety guards or housing removed.
- Maintenance and repairs must be performed by authorized personnel.
- Make sure all switches are turned "OFF" and battery connections are removed before performing any maintenance procedures.
- Store or park this machine on a level surface only.
- These machines are designed for level floor operation only. DO NOT OPERATE on ramps or inclines.

DANGER

- Battery acid can cause burns. When working on or around batteries, wear protective clothing and safety glasses. Remove metal jewelry. Do not lay tools or metal objects on top of batteries.

Charging batteries generates explosive gases. DO NOT CHARGE BATTERIES WHEN OPEN FLAMES OR SPARKS ARE PRESENT. DO NOT SMOKE. Make sure the charger is turned off before disconnecting it from the batteries. Charge the batteries in a well ventilated area.

SAVE THESE INSTRUCTIONS

SAFETY DECALS

DO NOT OPEN OR REMOVE
SAFETY SHIELDS WHILE
ENGINE IS RUNNING

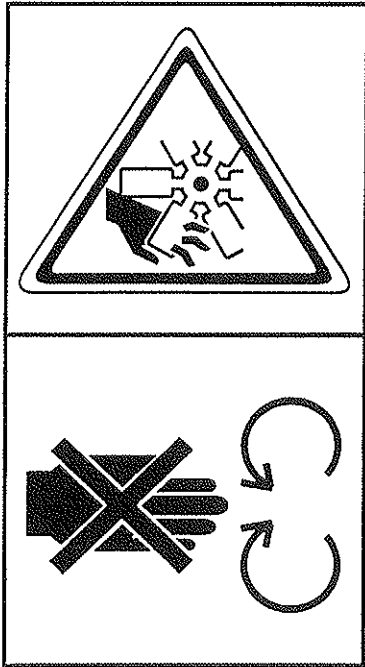

715300

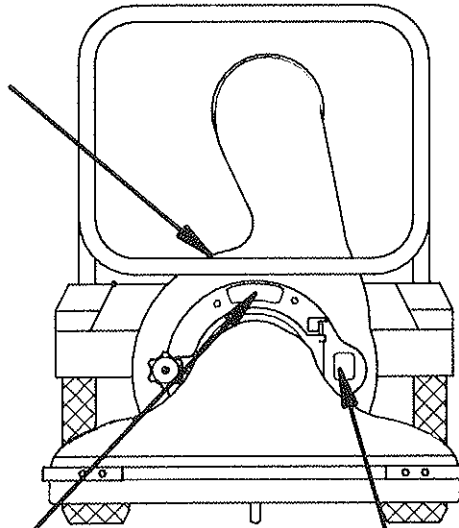

85-151-A



84-105A

ASSEMBLY INSTRUCTIONS

1. After removing the handle and vac unit from the carton, the following instructions will help you ready the vac for operation.
2. Remove the rolled up dust bag and Spin-Pak® from the spacer box. The rolled up dust bag contains the following items: Front caster 64-71-A, Bracket/caster 66-430-C, and Cables (1) 72-132-A and (2) 72-134-A, also, the plastic bag containing the following hardware: 63-304-A, 4 Bag hooks; 69-416-16, 2 Contour head bolts 1/4-20 x 1; 352-416, 2 Acorn nuts 1/4-20; 65-416-20, 2 Bolts-Hex head 1/4-20 x 1 1/4; 364-416, 2 Nuts-Hex Lock 1/4-20; 936-416, 2 Washer-Int. Tooth Lock 1/4; 365-516, 2 Nut-Hex Lock 5/16.
3. After removing the machine from the carton the first step is to install the caster bracket and insert the caster.
Attach the caster bracket (item 12) by removing (2) 1/4-20 x 1 bolts and washers (items 25 and 28) also (2) 1/4-20 x 1 1/4 bolts and washers (items 26 and 28) at the bottom of the front cover assembly, item 8). Now position the caster bracket so the part no. is on the top side. Insert (2) 1/4-20 x 1 bolts and washers (items 25 and 28) in the (2) top holes and screw into the front cover assembly. **Do not tighten.** Now insert (2) 1/4-20 x 1 1/4 bolts and washers (items 26 and 28) into the (2) bottom holes and screw into the front cover assembly. Now tighten all (4) bolts).
Next install the caster (item 13). Place the 3/4 nut (item 31) on the shank of the caster before screwing the caster into the caster bracket. Adjust height to suit. Turn 3/4 nut tight against bottom side of bracket to lock caster shank and maintain height setting.
4. Attach the top cross brace (ref. no. 9) with the left and right truss braces (ref. nos. 2 & 3) to the upper handle (ref. no. 1) with bolts and nuts (ref. nos. 4 & 5). **Do not tighten!** Now place the truss braces over bolts "A" on the cabinet and install nut (ref. no. 10). **Again, do not tighten!** Next place the upper handle (ref. no. 1) ends on top of lower handle which is attached to the blower housing. Now place the cross brace (ref. no. 9) on the bottom side of the lower handle and fasten together with bolts, washer, and nuts (ref. nos. 4, 6, 7 & 8). Now tighten all nuts and bolts on the handle assembly.
5. To attach intake housing to unit; Insert the hinge bosses, on collar of intake housing, behind the hinge extension on front cover assembly. Swing intake housing to lay flat against front cover assembly. Secure by placing flatwasher and adjusting knob, on pivot bolt, over the collar of intake housing and tightening adjusting knob.
6. The batteries should be installed next. Follow instructions under Battery Selection and Care to determine if batteries are in good condition. Place batteries in the cabinet in the positions shown in AF-1. Thoroughly tighten all terminal connections, coat with a thin application of petroleum jelly. Be sure the positive and negative posts are in the proper location. All the wires and battery cables have been attached to the cabinet except (1) 72-132-A and (2) 72-134-A, these were wrapped in the dust bag for shipping and can be identified by their lengths. AF-2 shows the complete wiring diagram.
7. To assemble Spin-Pak®; Remove the hex head bolts, lock nuts, and flatwashers, from the three upper holes used to secure the retaining ring to the blower housing. **Do not** remove the bottom bolt or the retaining ring from blower housing. Align the holes in the Spin-Pak® with the three upper holes in the remaining ring and blower housing. Reassemble to the hex head bolts, lock nuts, and flatwashers to the three holes and tighten.
8. Attach the dust bag to the unit by placing the bag hooks in the bottom loop of the top bag straps. Hook the straps on the upper handle just above the top cross brace. Slip the neck of the bag over the Spin-Pak® and retaining ring, pull the tie strap tightly around the neck of the blower housing.
WARNING: Battery charger selector switch **must** be in the **off** position and power cord to the charger **disconnected** before inspecting or servicing batteries. Make all connections or disconnects to batteries with charger off.
WARNING: Proper eye protection such as goggles, face shield or safety glasses should be worn with protective clothing such as rubber gloves and apron, when servicing or inspecting batteries.

OPERATING INSTRUCTIONS

1. Keep filter bag clean. The efficiency of this unit depends on the breathing capabilities of the dust bag. On extremely dusty jobs, empty bag often. Never allow debris to remain in bag after use. There is danger of spontaneous combustion.
2. Before starting the motor make sure the: A. Spin-Pak® is in place. B. Dust bag or discharge hose is in place. C. Intake housing or hose kit is attached to the fan housing.
3. Your Vac 35 is equipped with a front adjustable caster which will provide any height adjustment of intake housing that may be desired, within a practical range.
4. Your Vac 35 will handle most common kinds of debris found around industrial plants, commercial buildings, homes and farms. Acid contaminated materials, magnesium dust and other DANGEROUS debris that is considered hazardous should not be handled with Vac 35 unless approved by a regulating authority considered to be an expert in the handling of such hazardous materials.
5. **DO NOT WORK ON VAC 35** repairs or change attachments with motor running. Disconnect one battery wire for safety. Never walk away from the machine with the motor running.
7. LUBRICATION: Lubricate the wheels three to four times a year. (If used in an extremely duty area, lubricate more often.) The grease fittings are on the hub of each wheel. Lubricate the bearings and wheel axle on the caster once a week if used daily.

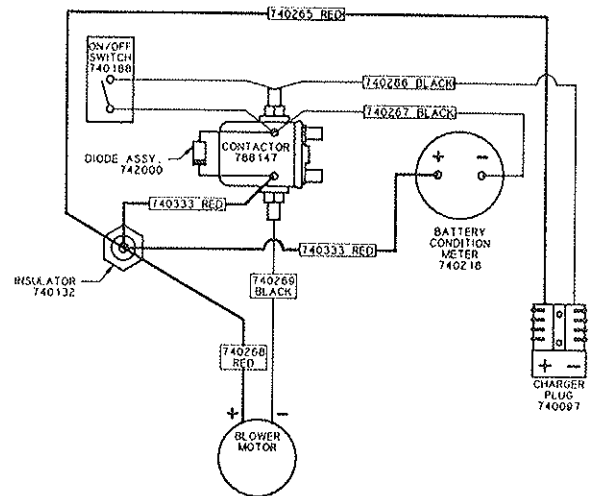

BATTERY SELECTION AND CARE

CAUTION: In handling storage batteries remember that battery electrolyte is composed of water and H₂SO₄ or sulfuric acid. If battery acid should contact any part of the body, wash immediately with clean cold water. Seek medical aid if any discomfort continues. The charging of these batteries creates explosive hydrogen and oxygen gases. Personnel should be properly instructed in the care and handling of this equipment before being permitted to do so (see Charging Instructions).

A volt meter has been provided on top of the battery cabinet adjacent to the switch. When the indicating needle reaches the red range, the batteries should be recharged. The sweeper will still sweep efficiently at this point; however, if batteries are continually discharged beyond this point, their life will be shortened considerably.

BATTERY POSITION & HOOK UP

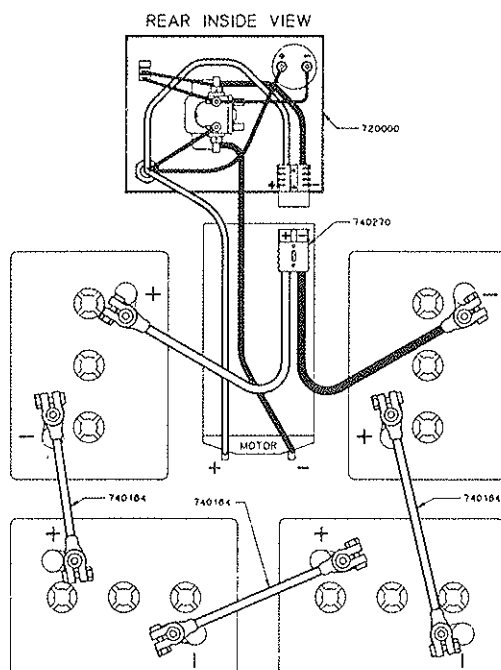

BATTERY SPECIFICATIONS

220 amps @ 20 hour rate 6 volt wet charge (4 required) PN 956720. 275 amps @ 20 hour rate 6 volt wet charge (4 required) PN956740.
 Battery Dimensions - 10 19/64 x width 7 5/64 x height 10 3/16.

BATTERY/CHARGER SPECIFICATIONS

Use charger no. 957722/72-287-A. Volt DC 24, Volt AC 115/Ph-1/cy-60. Available through the Parker Distributors listed on the back page of this owner's guide.

BLOWER HOUSING UNIT ASSEMBLY

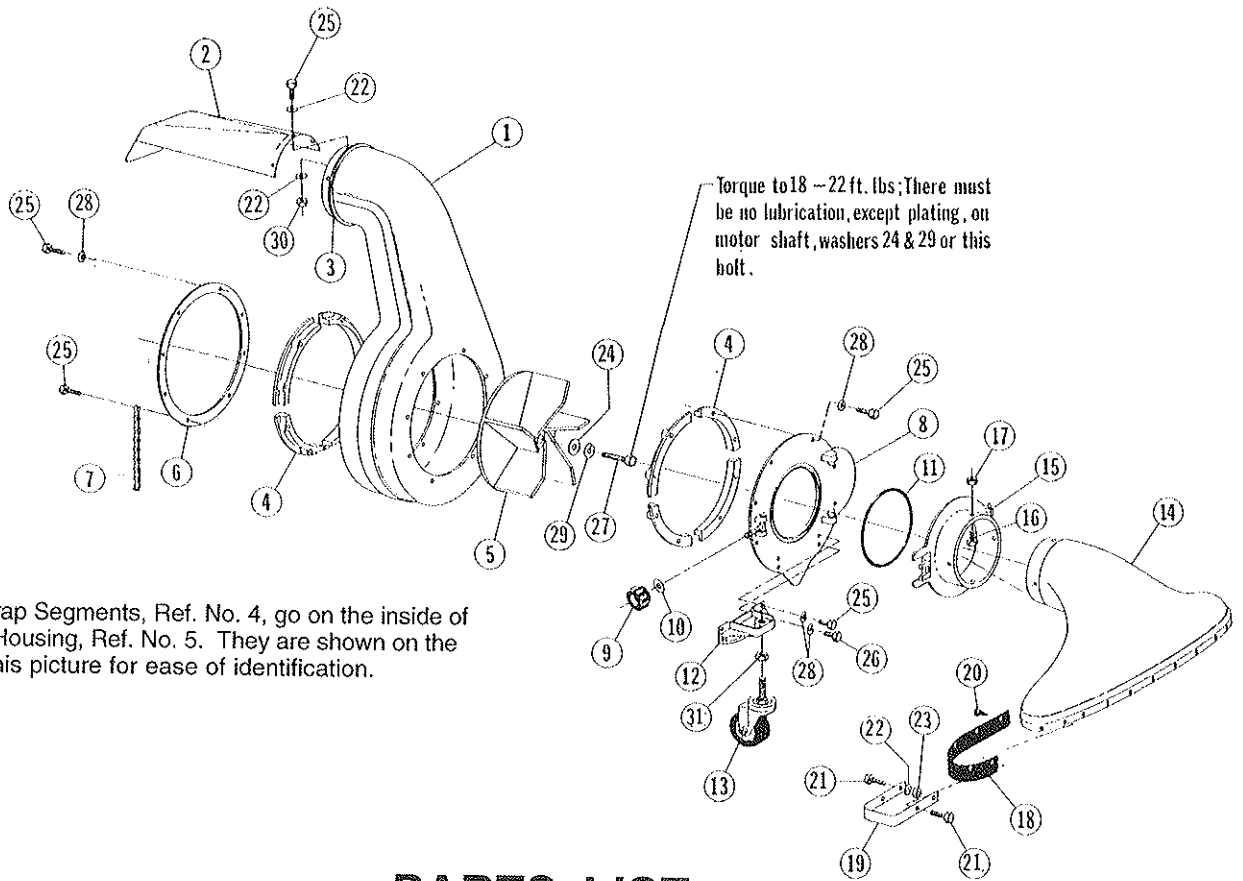

NOTE:

The Anti-Wrap Segments, Ref. No. 4, go on the inside of the Blower Housing, Ref. No. 5. They are shown on the outside in this picture for ease of identification.

PARTS LIST

Item	Part No.	Qty.	Description	Item	Part No.	Qty.	Description
1	70-103-D	1	Housing Assembly	**17	369-416	4	Nut, Serrated Hex Lock 1/4-20
2	85-110-B	1	Spin Pak®	18	73-67-D	1	Skirt
3	85-59-C	1	Retaining Ring	19	62-98-C	2	Guard
4	64-78-C	8	Anti-Wrap Segment	20	80-332-A	15	Fasteners
5	61-14-D	1	Fan Wheel	21	713002	8	Bolt, Hex Hd. 1/4-20 x 3/4
6	62-187-C	1	Rubber Gasket	22	711505	16	Flatwasher, Plain 1/4
7	47-219-A-8	2	Chain, Drag 8" Lg.	23	711377	8	Nut, Hex Lock (thin) 1/4-20
8	SA-1389-D	1	Front Cover Assembly	24	82-138-B	1	Washer, Special
*9	80-29-A	1	Adjusting Knob	25	713003	20	Bolt, Hex Hd. 1/4-20 x 1
*10	945-816	1	Flatwasher, Plain 1/2	26	713004	2	Bolt, Hex Hd. 1/4-20 x 1 1/4
*11	63-190-A	1	O-Ring Gasket	***27	60-516-16	1	Bolt, Hex Hd. 5/16-24 x 1
12	66-430-C	1	Caster Bracket	28	711544	16	Lockwasher, Spring 1/4
13	64-71-A	1	Caster, Stem Type	29	711545	1	Lockwasher, Spring 5/16
14	SA-647-D	1	Intake Housing Assy. 30"	30	711373	4	Nut, Hex Lock 1/4-20
**15	63-195-D	1	Collar	31	340-1216	1	Nut, Hex Jam 3/4-10
**16	713001	4	Bolt-Hex Hd. 1/4-20 x 5/8				

* Items 9, 10 and 11 are supplied with item 8 but can be purchased separately.

** Items 15, 16 and 17 are supplied with item 14 but can be purchased separately. Also items 14 through 23 can be purchased as a complete assembly, SA-911-D 30" Intake Housing.

*** Item 27; torque 5/16 bolt - 18 to 22 ft./lbs.

BATTERY CABINET ASSEMBLY

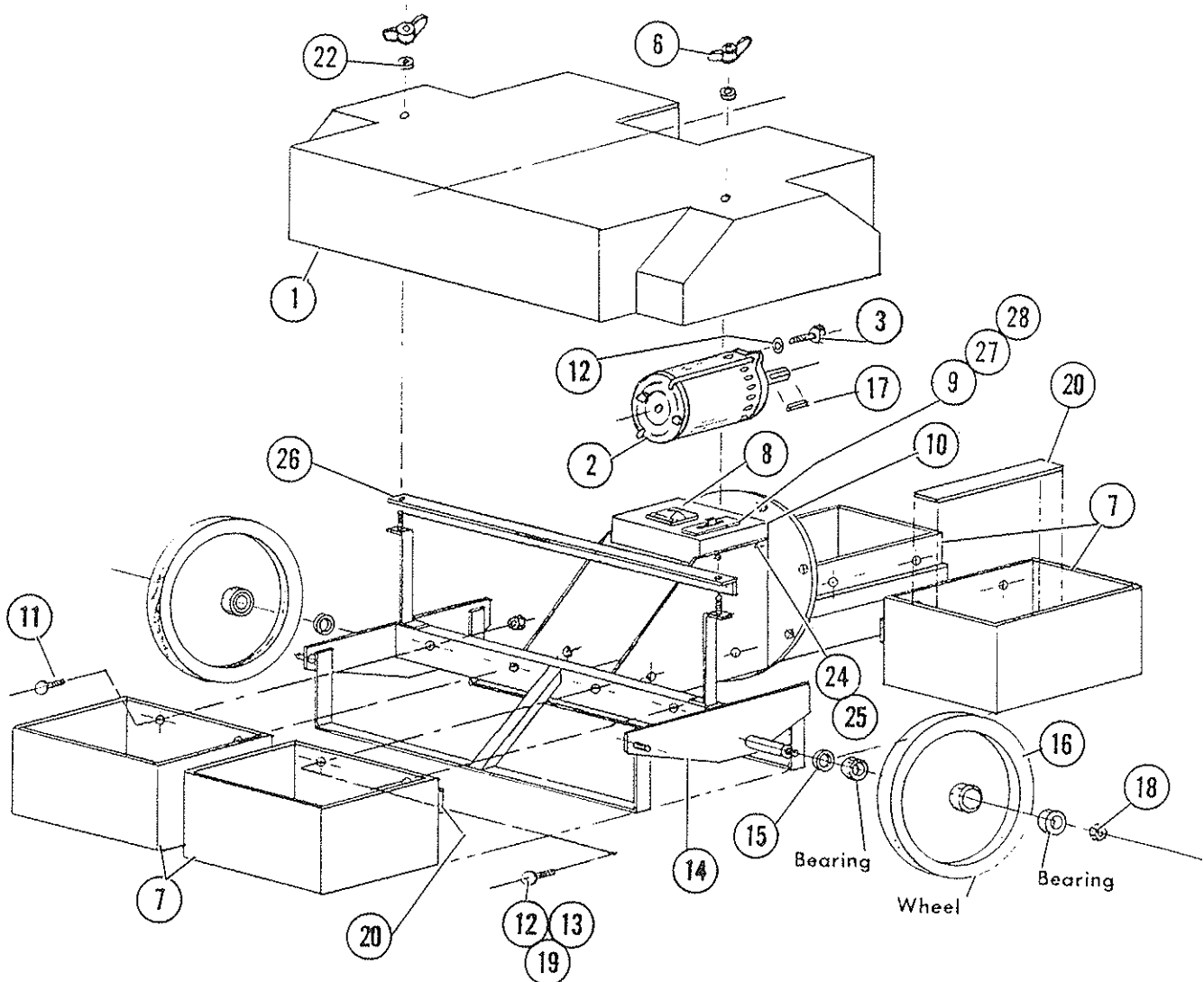

PARTS LIST

Item	Part No.	Qty.	Description	Item	Part No.	Qty.	Description
1	72-111-D	1	Deck, Battery Vac	15	66-431-A	2	Washer, Special
2	74-30-B	1	Electric Motor 1.1 HP DC	16	SA-334-C	2	Wheel Assembly
3	713001	4	Bolt, Hex Hd. 1/4-20 x 5/8		72-160-A	2	Bearing
6	351-416-18	2	Wing Nut		72-139-A	1	Wheel
7	72-116-C	4	Battery Box	17	74-83-A	1	Key
8	740216	1	Volt Meter	18	65-468-A	2	Nut, ESNA NTE 108 5/8-18
9	740188	1	Switch (on-off)	19	73-416-28	2	Bolt, Step 1/4 x 20 x 1 3/4
10	720000	1	Box Assembly	20	72-117-A	4	Rubber Strip (1 per box)
11	73-416-12	6	Bolt, Step 1/4-20 x 3/4	22	711505	2	Washer, Flat 1/4
12	711544	12	Washer, Spring Lock 1/4	24	711144	4	Screw, Rd. Hd., Mach Self-tap
13	711316	8	Nut, Hex 1/4-20	25	935-8	4	Washer, Spring Lock
14	72-115-F	1	Frame Weldment	26	73-139-A	1	Support, Deck Cover

HANDLE & BAG ASSEMBLY

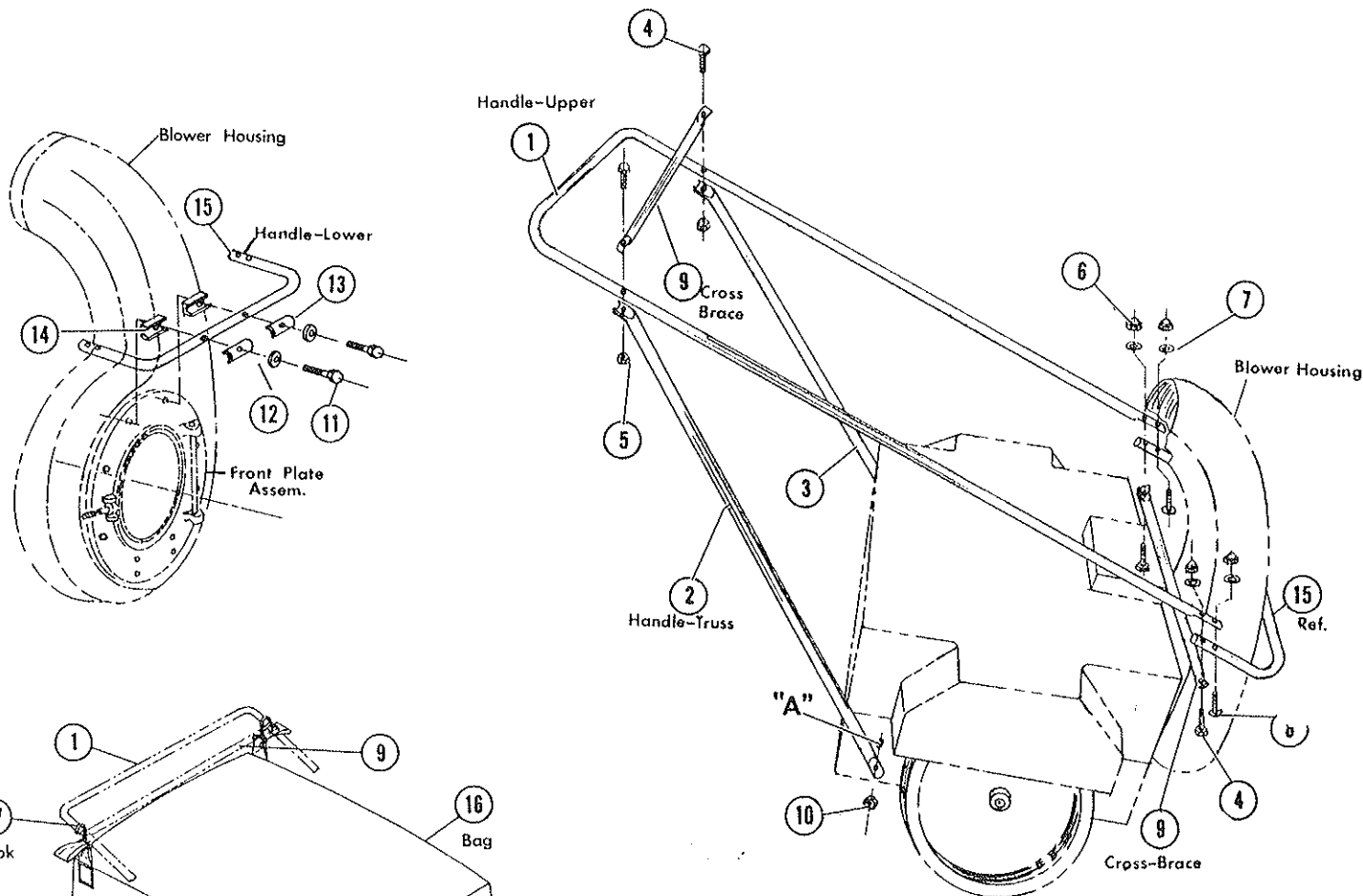

PARTS LIST

Item	Part No.	Qty.	Description
1	72-144-D	1	Upper Handle
2	72-141-C	1	Handle Truss - Brace R.H.
3	72-142-C	1	Handle Truss - Brace L.H.
4	713004	4	Bolt, Hex. Hd. 1/4-20 x 1 1/4
5	711377	2	Nut, Hex Lock (thin) 1/4-20
6	352-416	4	Acorn Nut, 1/4-20
7	936-416	4	Washer, Int. Tooth 1/4
8	69-416-16	2	Bolt, Cont. Hd. 1/4-20 x 1
9	72-143-B	2	Cross Brace
10	711374	2	Nut, Hex Lock 5/16-18
11	713008	2	Bolt, Hex Hd. 1/4-20 x 2 1/4
12	711544	2	Washer, Spring Lock 1/4
13	59-77-A	2	Clamp
14	72-150-A	2	Spacer, Handle
15	72-145-C	1	Handle, Lower
16	MA-419-D	1	Bag Assembly
17	63-304-A	4	Hooks
18	SA-794-B	1	Strap Assembly

Deflector Weldmt.

Blower Housing

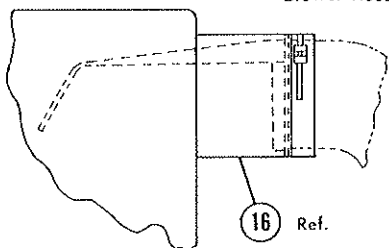

ELECTRICAL BOX ASSEMBLY

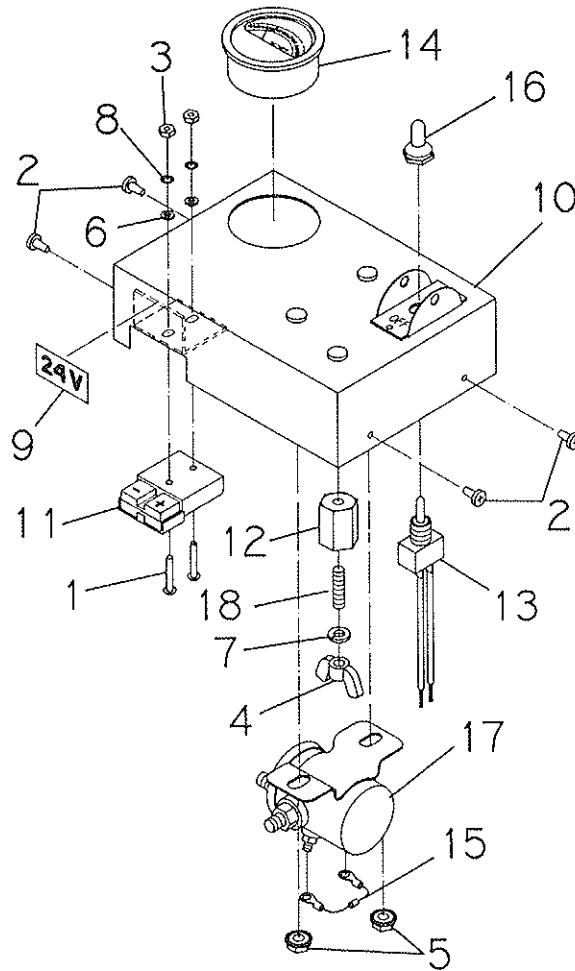

PARTS LIST

Item	Part No.	Qty.	Description
1	710207	2	Screw, MC 6-32 x .88 STPL
2	711124	4	Screw, ST 10 x .38 NP
3	711301	2	6-32 Hex Nut STPL
4	711368	1	1/4-20 Nyloc Wing Nut
5	711425	2	1/4-20 Flanged Wizz Nut
6	711502	2	#8 Flat Washer
7	711544	1	1/4 Lock Washer
8	711551	2	#6 Internal Tooth Lockwasher
9	715106	1	Decal 24V
10	720000	1	Electrical Box Weldment
11	740097	1	Red Plug Housing, CB50
12	740132	1	Glastic Insulator
13	740188	1	On/Off Switch, 20 amp 1.5 HP
14	740216	1	Battery Condition Gauge
15	742000	1	Diode Assembly
16	760650	1	Hex Seal Switch Boot
17	788147	1	Solenoid, 24V DC
18	833638	1	1/4-20 x 1" Brass Stud

LIMITED WARRANTY

The Parker Sweeper Company warrants to the original purchaser/user that this product is free from defects in workmanship and materials under normal use and service for a period of two years from date of purchase. In addition, Parker Sweeper Company, will, at its option, honor labor warranty claims for the first 12 months from date of sale, provided such claims are submitted through and approved by factory authorized repair stations. Parker Sweeper Company, will, at its option, repair or replace without charge, except for transportation costs, parts that fail under normal use and service when operated and maintained in accordance with the applicable operation and instruction manuals.

This warranty does not apply to normal wear, or to items whose life is dependent on their use and care, such as belts, cords, switches, hoses, rubber parts, electrical motor components or adjustments. Parts not manufactured by Parker Sweeper Company such as engines, batteries, battery chargers, hydraulic pumps, and tires are covered by and subject to the warranties and/or guarantees of their manufacturers. Please contact Parker Sweeper Company for procedures in warranty claims against these manufacturers.

Special warning to purchaser -- Use of replacement filters and/or prefilters not manufactured by Parker Sweeper Company or its designated licensees, will void all warranties expressed or implied.

A potential health hazard exists without exact original equipment replacement.

All warranted items become the sole property of Parker Sweeper Company or its original manufacturer, whichever the case may be.

Parker Sweeper Company disclaims any implied warranty, including the warranty of merchantability and the warranty of fitness for a particular purpose. Parker Sweeper Company assumes no responsibility for any special, incidental or consequential damages.

This limited warranty is applicable only in the U.S.A. and Canada, and is extended only to the original user/purchaser of this product. Customers outside the U.S.A. and Canada should contact their local distributor for export warranty policies. Parker Sweeper Company is not responsible for costs or repairs performed by persons other than those specifically authorized by Parker Sweeper Company. This warranty does not apply to damage from transportation, alterations by unauthorized persons, misuse or abuse of the equipment, use of non-compatible chemicals, or damage to property, or loss of income due to malfunctions of the product.

If a difficulty develops with this machine, you should contact the dealer from whom it was purchased.

This warranty gives you specific legal rights, and you may have other rights which vary from state to state. Some states do not allow the exclusion or limitation of special, incidental or consequential damages, or limitations on how long an implied warranty lasts, so the above exclusions and limitations may not apply to you.

The Parker Sweeper Company

P.O. Box 1728
Springfield, OH 45501-1728
Phone: (513) 323-4901
Fax: (513) 322-5462