

ASSEMBLY INSTRUCTIONS
OPERATING INSTRUCTIONS
AND PARTS LIST
FOR

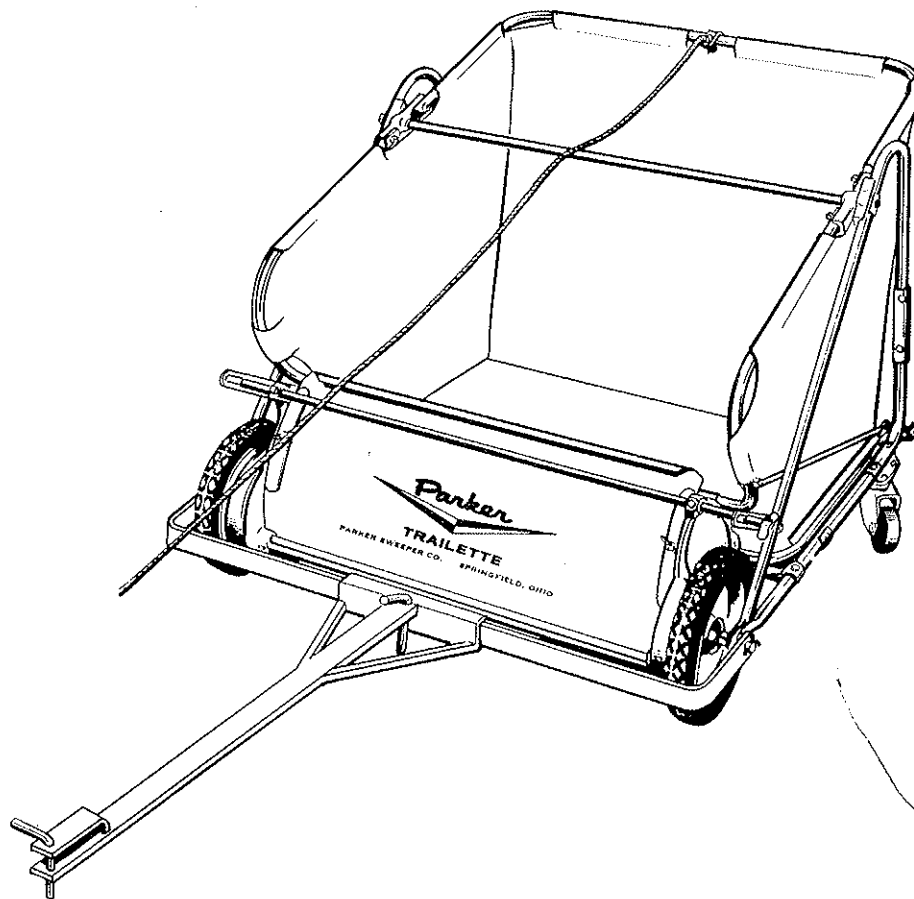

TE-16430 TRAILETTE
30" LAWN SWEEPER



NOTICE: These instructions were written to assist you in assembling your Tralette Lawn Sweeper quickly and correctly. Read instructions thoroughly before attempting assembly so that you are familiar with the complete procedure.

PARKER SWEEPER COMPANY

BOX 720

SPRINGFIELD, OHIO

ASSEMBLY INSTRUCTIONS

1. Raise upper frame (see Fig. 1) until end sits on end of lower frame.
2. Position two rounded brackets at Point A, Fig. 1, and hold with two short bolts and two nuts. Assemble opposite side similarly and tighten nuts.

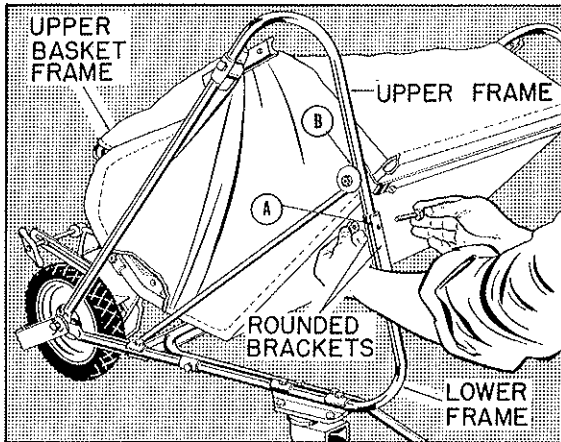

Fig. 1

3. At Point B, Fig. 1, release basket bottom from behind upper frame, by lifting up until washer and bolt assembly can be moved toward center of machine. Allow basket bottom to drop to lower frame extension.
4. Swing upper basket frame (see Fig. 1) over to rear of sweeper.
5. Position lower basket frame onto aluminum casting at Point C, Fig. 2. Insert long bolt through hole and add short rounded bracket and nut. Assemble opposite side similarly and tighten nuts.
6. Remove nut at Point D on lower basket frame at front, Fig. 3. Position end of long straight bar (basket brace) onto bolt and replace nut. Assemble opposite bar (basket brace) the same and tighten nuts. (Turn to Basket Assembly, Fig. 3 in parts list, for assembled view).

7. Turn to Fig. 4 (Hitch Assembly). Remove Ref. 2 from short heavy pin, Ref. 4. Position hitch onto Ref. 4 and lock in place with Ref. 2.

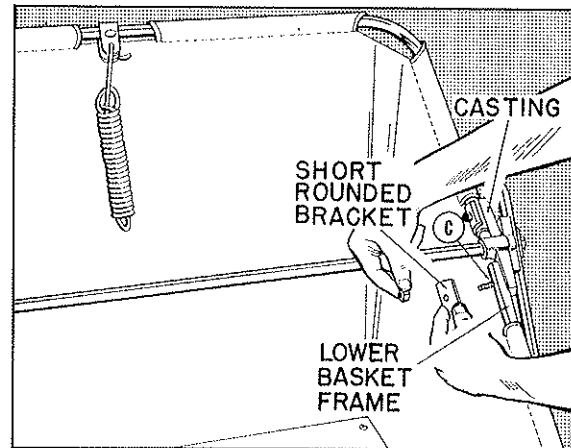

Fig. 2

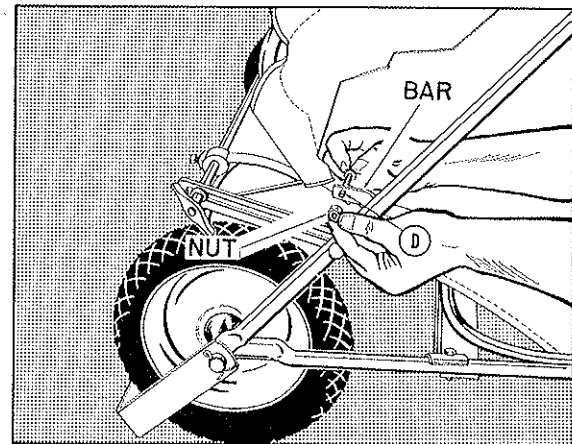

Fig. 3

OPERATING INSTRUCTIONS

Brush Height Adjustment. Loosen large wing nut, Ref. No. 24, Fig. 2. To raise brushes to extreme height, pull sweeping unit forward as far as slots in brush adjustment brackets, Ref. No. 1, Fig. 2, will permit. To lower brushes to lowest position, push sweeping unit backward as far as slots will permit. Secure wing nut when desired brush adjustment is obtained.

Hood Height Adjustment. Loosen two wing nuts, Ref. No. 4, Fig. 1, and adjust hood, Ref. No. 6, to desired height. Retighten wing nuts.

1. For grass clippings or leaves, adjust hood and brushes at highest position. After trial run on lawn, should the settings be too high, lower slightly and try again until correct setting is found. Brush life may be prolonged by adjusting so contact with ground is light. The lighter the contact, the longer the wear and easier to pull.

2. For patio, sidewalk and driveway sweeping, adjust hood to bottom position. The hood is in correct position when it does not drag or throw sweepings ahead of sweeper. Also adjust brushes so they just contact cement.

NOTE: IF SWEEPER PULLS HARD, THE BRUSHES OR HOOD ARE SET TOO LOW.

Basket Dumping. The load is dumped from basket by pulling basket forward with rope, causing basket to pivot into a semi-inverted position. When load is dis-

charged, allow rope and basket to return to its normal position.

Maintenance. Place a few drops of oil into the two oilers which are located on each side plate, Ref. Nos. 7 and 17 of Fig. 1, every time the machine is used. The wheels and casters should be lubricated at the same time. A drop or two of oil should also be applied occasionally to the basket pivot block, Ref. No. 26, Fig. 3.

Care and Replacement of Brushes. The brushes used on this sweeper are made of the finest bristles that will give years of service if given proper care. Should they become bent from constant use, it is possible to straighten bristles by reversing the brushes on the reel shaft, so that the sweeping pressure is applied from the opposite side.

To reverse or replace brushes:

1. Turn sweeper upside down.
2. Remove cap screws & clamps items 8 & 24 Fig. 3 which hold the brush strips to the reel shaft brackets. Reverse and replace the brush strip and clamps, then retighten the cap screws.

CAUTION: The brush fiber and basket material will burn if in contact with open flame. Avoid dumping basket near fire.

Basket Care. To insure longer basket life empty after each use.

TRAILLETTE TRAILER SWEEPER	SIZE 30"	PRODUCTION YEAR 1969	MODEL No. TE-16430
---------------------------------------	--------------------	--------------------------------	------------------------------

UNIT ASSEMBLY

Figure 1

Ref. No.	Part No.	Qty. Per Unit	Description	Ref. No.	Part No.	Qty. Per Unit	Description
1	62-12-B	1	Hood Extension	19	58-05-A	4	Special Washer
2	*515-10-8	3	Rd. Hd. Screw—10-24 x 1/2	20	58-148-D-1	2	Wheel
3	*945-516	2	Flat Washer—S.A.E. 3/8	21	53-01-B	2	Tire R/W 68-270-B
4	*351-516-20	2	Wing Nut—3/8-18	22	62-04-A	1	Front Tie Rod
5	49-11-A	2	Hood Clamp	23	53-20-A	2	Hub Cap
6	62-13-D	1	Hood R/W 62-58-D	24	*325-816	2	Hex Nut—1/2-20
7	SA-116-RC	1	Side Plate—R.H. R/W 76-338-RF	25	345-816	2	Hex Jam Nut—1/2-20
8	*346-10	3	Speed Nut—No. 10	26	58-06-A	2	Sleeve
9	560-516-10	6	Sq. Hd. Set Screw—1/4-20 x 5/8	27	*505-416-8	4	Flat Hd. Screw—1/4-20 x 1/2
10	*66-516-12	2	Sq. Hd. Bolt—3/8-18 x 3/4	28	946-1016-16	2	Fiber Washer
11	61-416-8	8	Bolt - Hex. Hd. 1/4-28 x 1/2	29	45-56-18-RCA	1	Pinion Gear—R.H. (not shown)
12	62-06-A	1	Adjusting Tube	45-56-19-LCA	45-56-19-LCA	1	Pinion Gear—L.H. (shown)
13	1200-14.5	8	Brush	30	50-33-A	2	Special Washer
14	53-176-D	2	Reel Guard	31	53-35-A	2	Axle
15	45-25-A	2	Pinion Pawls	32	48-336-A	2	Bearing R/W 68-60-A
16	62-68-A	1	Rear Tie Rod	33	69-06-B	1	Reel Shaft
17	SA-117-LC	1	Side Plate—L.H. R/W 76-339-LF	34	69-04-A	8	Clamp - Brush
18	56-94-B	2	Pinion Gear Cover R/W 80-01-B	35	65-416-28	2	Bolt - Hex. Hd. 1/4-20 x 1 3/4
				36	365-416	2	Nut - Lock 1/4-20

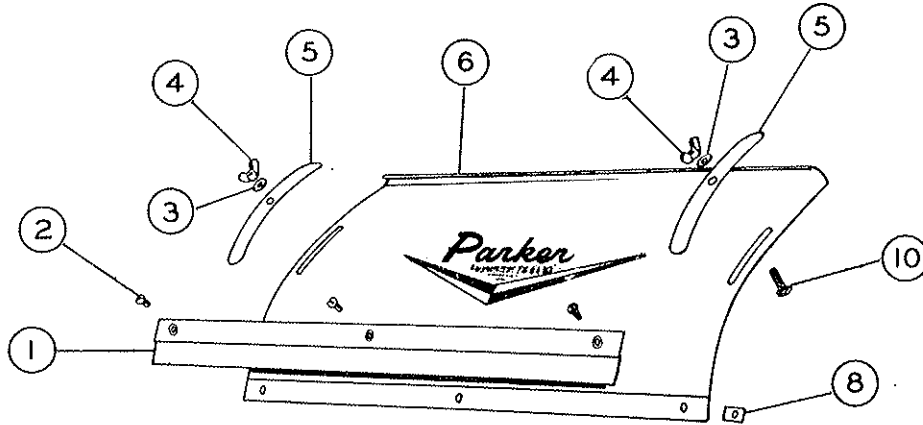
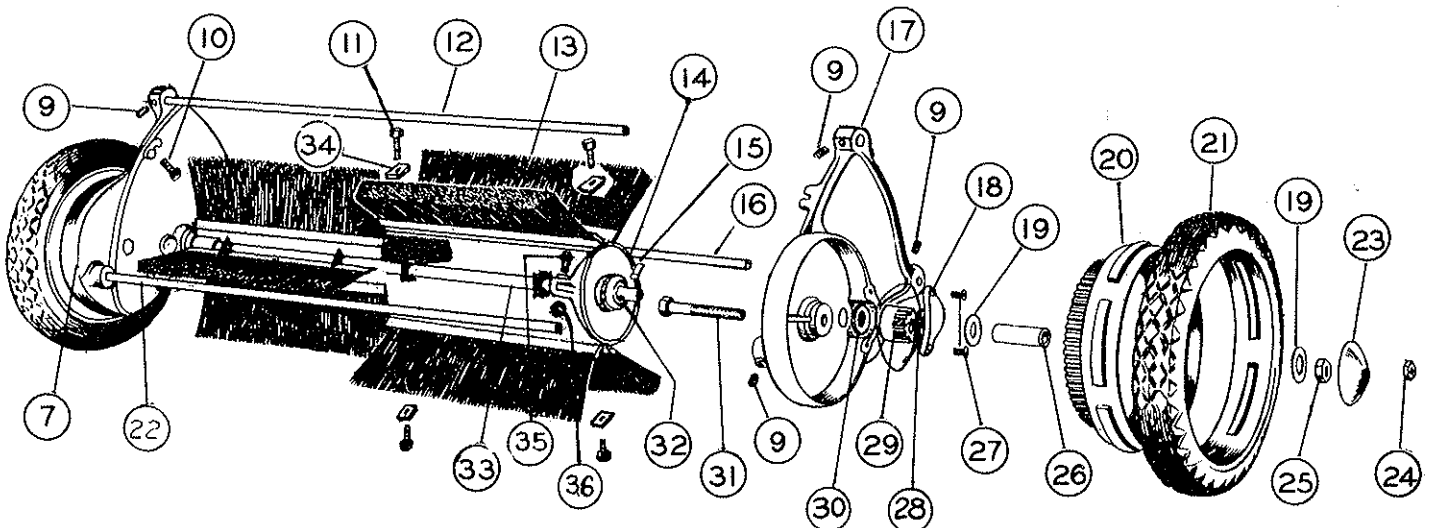

FIGURE 1



FRAME ASSEMBLY

Figure 2

Ref. No.	Part No.	Qty. Per Unit	Description	Ref. No.	Part No.	Qty. Per Unit	Description
1	59-59-A	2	Brush Adjusting Bracket	13	59-65-RF	1	Lower Frame—R.H.
2	59-14-A	1	Spacer	14	62-65-F-1	1	Frame Bottom Basket
3	*945-516	5	Flat Washer—S.A.E. $\frac{5}{16}$	15	58-133-A	2	Caster R/W 69-119-A
4	59-64-LF	1	Upper Frame—L.H.	16	59-69-B	2	Caster Plate
5	*70-516-24	2	Carriage Bolt— $\frac{5}{16}$ -18 x $1\frac{1}{2}$	17	*65-416-24	8	Hex Hd. Bolt— $\frac{1}{4}$ -20 x $1\frac{1}{2}$
6	365-516	2	Lock Nut— $\frac{5}{16}$ -18	18	59-66-LF	1	Lower Frame—L.H.
7	54-227-A	2	Spacer	19	*65-416-12	4	Hex Hd. Bolt— $\frac{1}{4}$ -20 x $\frac{3}{4}$
8	59-63-RF	1	Upper Frame—R.H.	20	62-07-A	1	Adjusting Bolt
9	58-124-C	4	Clamp—Handle	21	345-816	2	Hex Jam Nut— $\frac{1}{2}$ -20
10	*65-416-20	9	Hex Hd. Bolt— $\frac{1}{4}$ -20 x $1\frac{1}{4}$	22	59-77-A	8	Tube Clamp
11	365-416	23	Lock Nut— $\frac{1}{4}$ -20	23	*65-416-32	2	Hex Hd. Bolt— $\frac{1}{4}$ -20 x 2
12	63-290-C	1	Tie Bar	24	351-516-40	1	Wing Nut

FIGURE 2

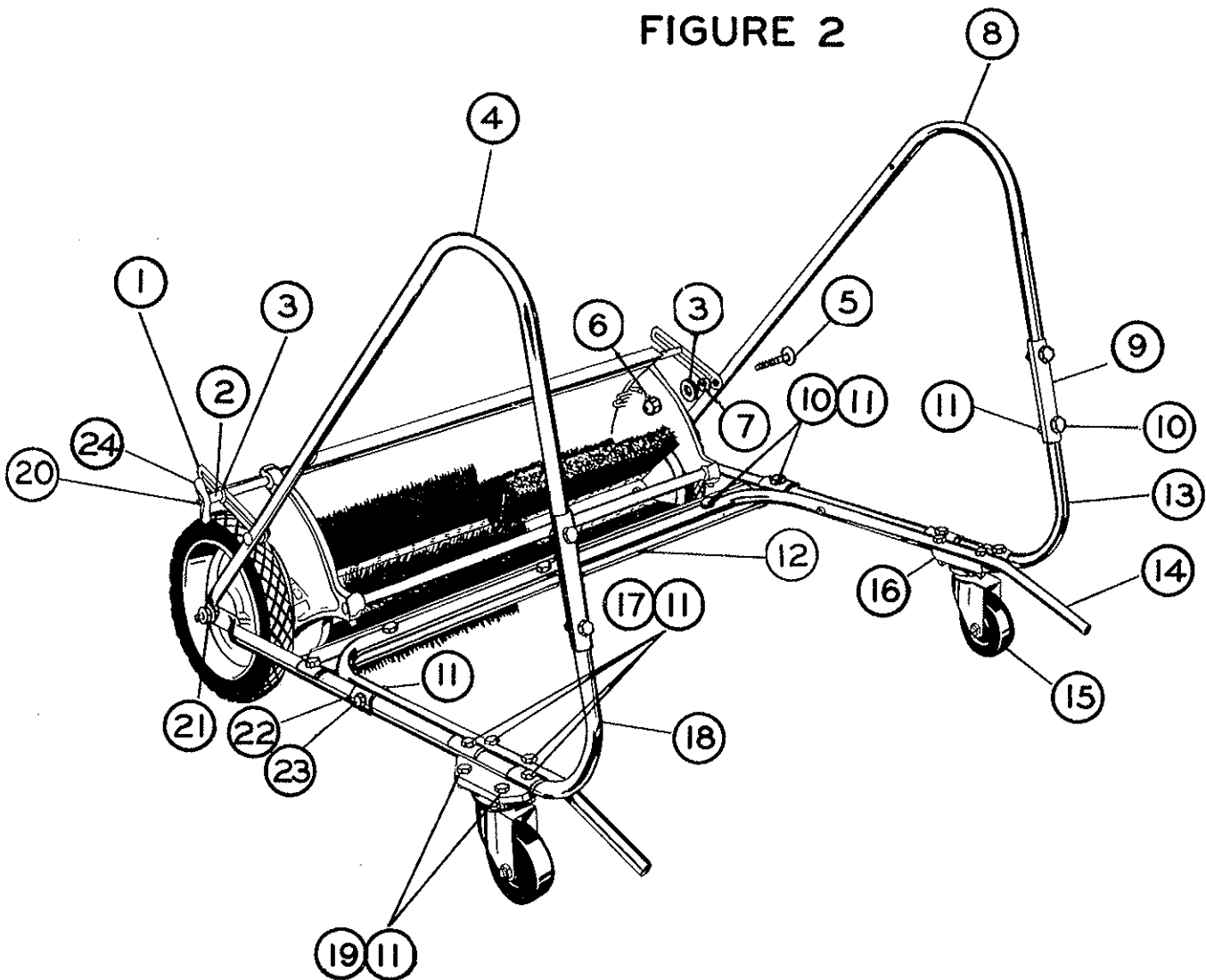

TRAILLETTE TRAILER SWEEPER	SIZE 30"	PRODUCTION YEAR 1969	MODEL No. TE-16430
---------------------------------------	--------------------	--------------------------------	------------------------------

BASKET ASSEMBLY

Figure 3

Ref. No.	Part No.	Qty. Per Unit	Description	Ref. No.	Part No.	Qty. Per Unit	Description
1	62-60-F	1	Rear Basket Frame	16	*945-416	2	Flat Washer—S.A.E. ¼
2	*70-516-20	1	Carriage Bolt— $\frac{3}{16}$ -18 x 1½	17	62-59-F	1	Lower Basket Frame
3	*936-516	2	Lock Washer— $\frac{3}{16}$	18	62-54-B	1	Pivot Rod
4	365-516	3	Lock Nut— $\frac{3}{16}$ -18	19	59-74-LD	1	Front Basket Frame—L.H.
5	59-60-A	1	Bracket	20	62-56-C	1	Clamp
6	60-09-A	1	Rope	21	*515-416-6	4	Rd. Hd. Screw—¼-20 x ¾
7	62-61-F	1	Basket Canvas	22	*346-416	4	Speed Nut—¼
8	*65-416-24	4	Hex Hd. Bolt—¼-20 x 1½	23	59-73-RD	1	Front Basket Frame R.H.
9	365-416	6	Lock Nut—¼-20	24	59-68-B	2	Short Pivot Block R/W 80-265
10	*65-616-40	2	Hex Hd. Bolt— $\frac{3}{8}$ -16 x 2½	25	59-77-A	8	Tube Clamp
11	63-291-A	2	Spacer	26	59-62-B	2	Long Pivot Block R/W 79-112
12	*65-516-28	2	Hex Hd. Bolt— $\frac{3}{16}$ -18 x 1½	27	63-292-A	1	Spreader
13	55-156-A	2	Special Washer	28	*65-416-12	2	Hex Hd. Bolt—¼-20 x ¾
14	62-55-B	1	Bar	29	365-616	2	Lock Nut— $\frac{3}{16}$
15	63-293-B	2	Basket Brace	30	*65-516-24	2	Hex Hd. Bolt— $\frac{3}{16}$ -18 x 1½

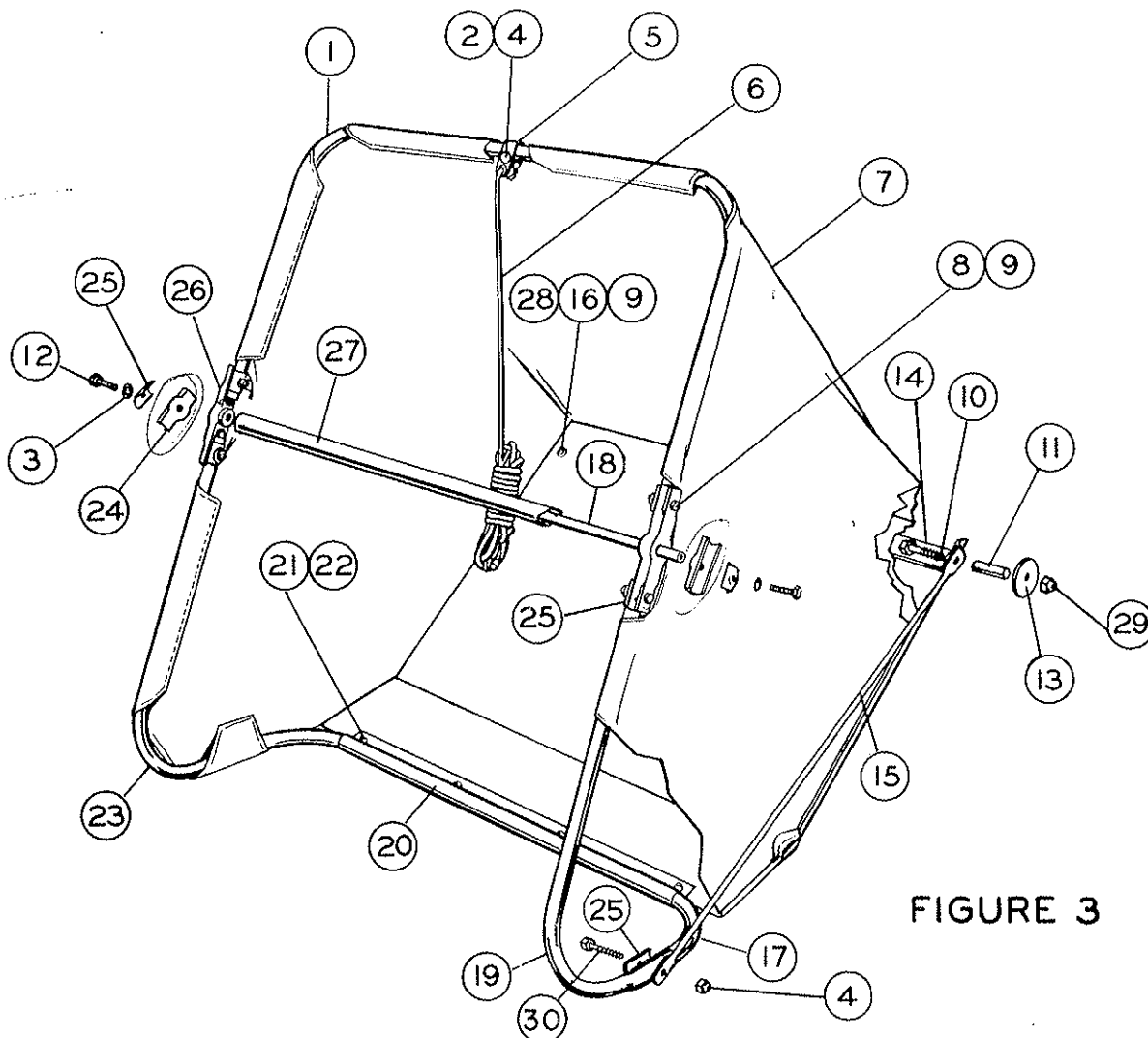

FIGURE 3

HITCH ASSEMBLY

Figure 4

ITEM	PART No.	QTY.	DESCRIPTION
2	58-113-A	2	Pin-Hitch <i>R/W</i> 81-14-A
3	58-111-C	1	Tongue-Hitch Assembly
4	58-115-A	1	Pin-Swivel
5	62-31-D	1	Yoke Subassembly
6	380-432-24	2	Pin-Cotter
7	53-198-A	2	Axle-Extension

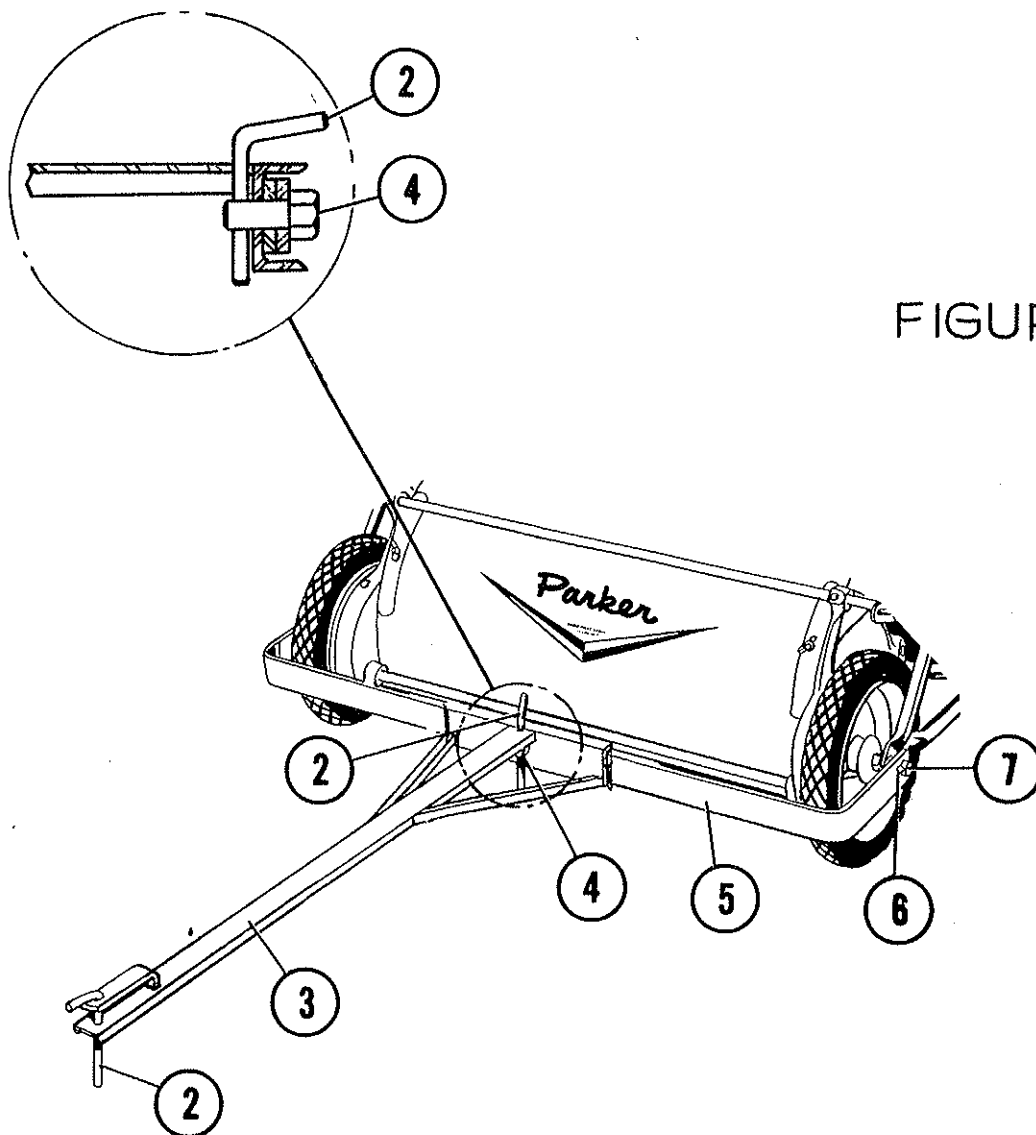

FIGURE 4