

OWNERS GUIDE



SV-8330 SCAVENGER®

30" VACUUM SWEEPER

RED

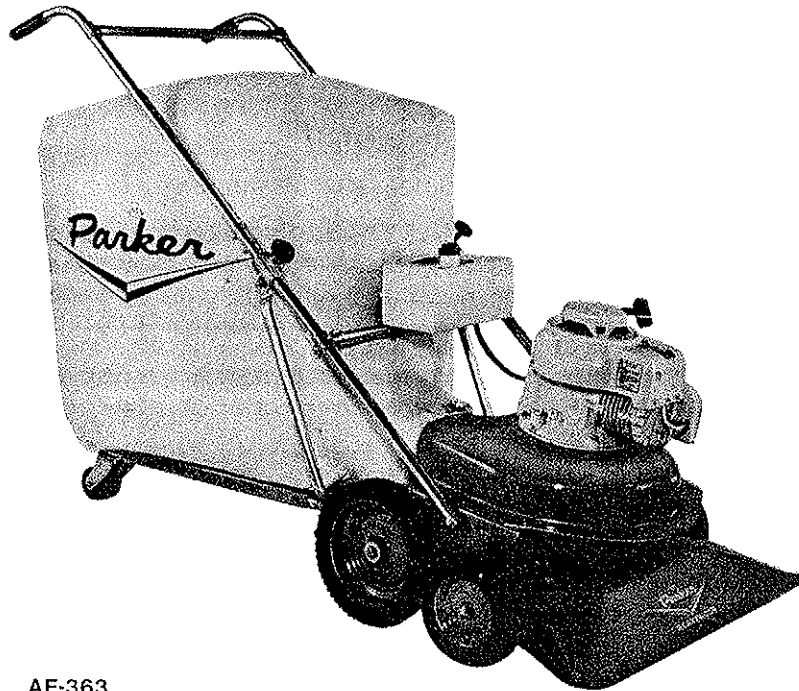

AF-363

**READ THESE INSTRUCTIONS
BEFORE SETTING UP AND OPERATING MACHINE**

PARKER SWEEPER COMPANY Box 1728 Springfield, Ohio 45501-1728

Plate No. 932

TO THE OWNER

These instructions were written to assist you in the assembly and operation of your Scavenger. **READ THE INSTRUCTIONS** thoroughly **BEFORE** attempting to assemble and operate the machine so that you are familiar with the complete procedure and the safety precautions.

RULES FOR SAFE OPERATION



The following safety precautions are suggested to prevent damage to the equipment or injury to the operator or nearby persons.

1. Do not allow anyone to operate the Scavenger without proper instructions.
2. Do not permit children to operate the Scavenger.
3. Do not sweep too close to fire. Ingesting hot ashes will ignite the bag.
4. Stop the engine before reaching into the intake nozzle or discharge chute to dislodge sticks or other debris.
5. Stop the Engine before attempting to make any adjustment or performing any maintenance work on the Scavenger.
6. When working on the engine, always remove the spark plug wire from the engine and attach it to the V shaped clip on the engine head.
7. Do not run the engine in an enclosed area. Exhaust gases contain carbon monoxide, an odorless and deadly poison.
8. Do not fill the fuel tank while the engine is running. Spilling gasoline on a hot engine may cause a fire or an explosion.
9. While machine is running, do not leave it unattended.
10. Before using the machine to pick up debris, police the area to be cleaned first, picking up any large objects such as cans, toys, dog bones and chunks of wood. If these pass through the machine, they could damage the impeller, bend the engine crankshaft or put a hole in the bag.
11. Avoid using the machine in dangerous places where steep slopes or loose debris will endanger the safety of the operator or other people.
12. Keep all nuts, bolts and screws tight to be sure the Scavenger is in safe working condition.
13. Follow the maintenance instructions as outlined in this manual.
14. Do not start or run engine unless bag is properly secured as injury may result.

IMPORTANT

ALWAYS GIVE THE FOLLOWING INFORMATION WHEN ORDERING REPAIR PARTS:

- | | |
|-------------------------------|---------------------------|
| 1. Part Number (Not Ref. No.) | 3. Description of Part |
| 2. Quantity Needed | 4. Model No. of Scavenger |

If unable to obtain parts locally, write down above information and send to:
PARKER SWEEPER CO., BOX 1728, SPRINGFIELD, OHIO 45501

Your unit is right hand (R.H.) or left hand (L.H.) as you stand behind it.

ASSEMBLY INSTRUCTIONS

1. Lower Handle has to be attached to the side of the unit at side plate in between the two wheels.
2. Remove the Hex. Lock Nut from the bolt on the end of lower handle and insert the bolt into the hole in the side plate with the handle and flatwasher against the side.
3. Add the Hex. Lock Nut back and tighten. Repeat for opposite side.
4. To attach the upper handles to the lower handles, remove contour head bolts, lockwashers and hex nuts.
5. Slide the ends of the upper handles down over the ends of the lower handles.
6. Re-insert the contour head bolts into the handles and screw on the lockwasher and hex nut.
7. NOTE: Be sure torque knobs are tightened securely.

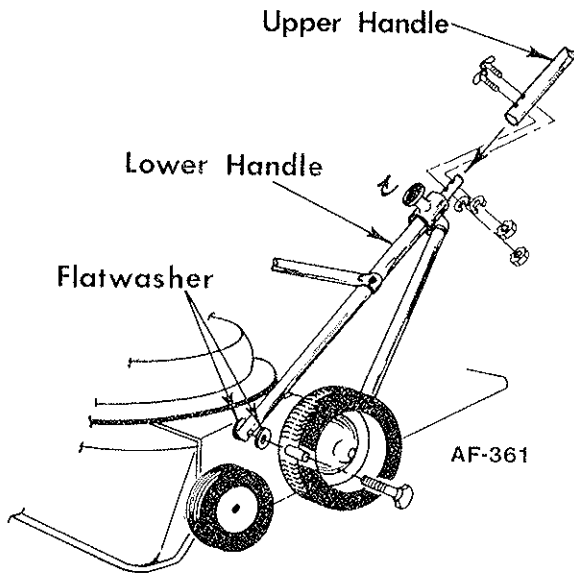

DUST BAG CARE

1. Keep the Dust Bag clean at all times.
2. To clean the Dust Bag, turn the bag inside out and reattach to the sweeper.
3. Start the engine and run at full throttle. Lightly tap the bag to release the dust trapped in the weave.
4. When the bag is clean, remove it and turn it right side out again. Reattach to the sweeper and resume sweeping.
5. DO NOT wash the Dust Bag to clean. Washing will shrink the material, reducing air flow through the bag and seriously reduce vacuum.

The efficiency of this unit depends on the breathing capacity of the Dust Bag. Under extremely dusty conditions the bag should be emptied and cleaned frequently. Always empty and clean bag before storing after use. Debris allowed to remain in the bag may cause spontaneous combustion, resulting in an explosion or fire.

ATTACHING DUST BAG

1. Attach the dust bag to the sweeper by placing the loops over the handles.
2. Bag hooks are not necessary on new manual Scavengers with Bag Platform. The Bag Platform will help support the bag. If your unit is used for any reason without the Bag Platform, then bag hooks should be used on the lower straps and lower crossbar.
3. To prevent loss of the bag hooks, be sure that the end of the hooks are closed after attaching to the bag straps. This can be done by a light blow with a hammer or by squeezing the pliers.

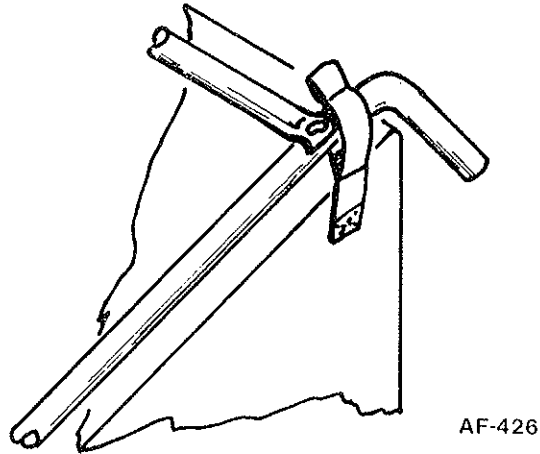

Slide the bag deflector over the discharge chute, as shown. Engage the strap into the buckle and tighten to retain bag deflector. Slip the neck of the bag over the bag deflector and discharge housing until the tightening strap passes over the bag deflector to rest on the discharge housing. Pull the strap tight to secure the bag to the unit.

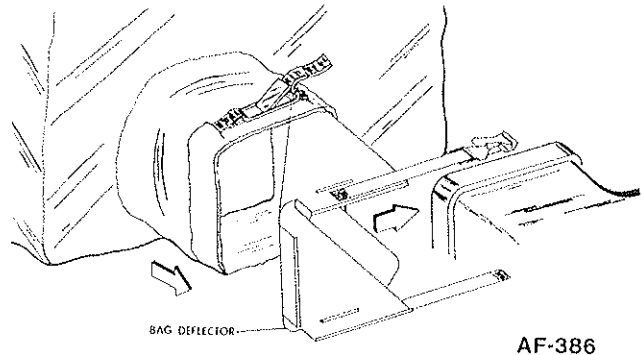

NOTE: Unit can be used as a blower by removing bag and reversing deflector.

ASSEMBLY INSTRUCTIONS

HEIGHT ADJUSTMENT:

With the new side 5 position wheel adjustment it has been made possible to sweep up against the curbs, buildings, etc., from both sides or front. The height of the intake nozzle can be adjusted by the two smaller side wheels. By pulling the spring lever away from the bracket you will be able to move the tire up or down. Be sure the pin on the lever is properly seated in one of the 5 holes in the bracket. Move the tire up or down the same amount on both sides. NOTE: Be sure wheels are locked into position and level.

TO ADJUST NOZZLE
PULL OUT AND SLIDE
FRONT TIRE UP OR DOWN

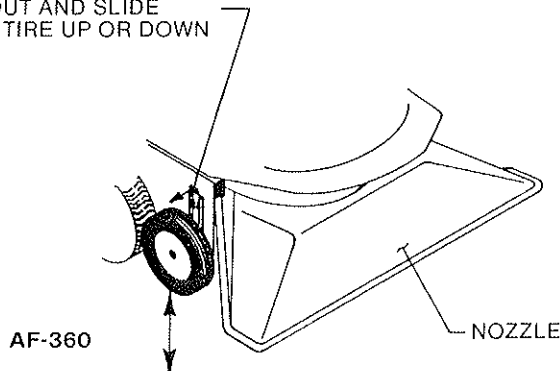

BAG PLATFORM:

Remove the contour Hd. bolt, lockwasher and hex. nut from the open end of the bag platform. Insert the ends of the bag platform onto the ends of the end caps as shown. Insert the contour bolt through tubing and end cap and secure with lockwasher and hex. nut. Your bag platform was made to support the bag and keep it from dragging the floor, do not use it to carry any other object because damage may occur.

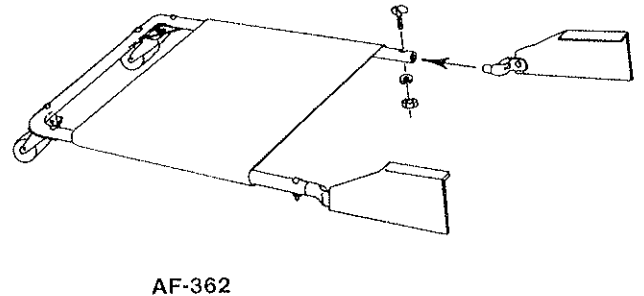

TOWING INSTRUCTIONS

The Scavenger may be towed by tractor from the back of the unit. This will require the purchase of an optional trailing hitch kit to provide properly controlled towing.

The Trailing Hitch Kit is attached directly to the bag platform and lower sideplates. It can be used on manual push type Scavengers only. All instructions and hardware necessary to assemble and operate the hitch will be included in the kit. Towing the unit by any other means could result in damage to the unit and/or operator. To order a Trailing Hitch Kit see your local Parker distributor or Parker Sweeper Company directly.

Scavenger Trailing Hitch Kit
Part No. MA-489-C.

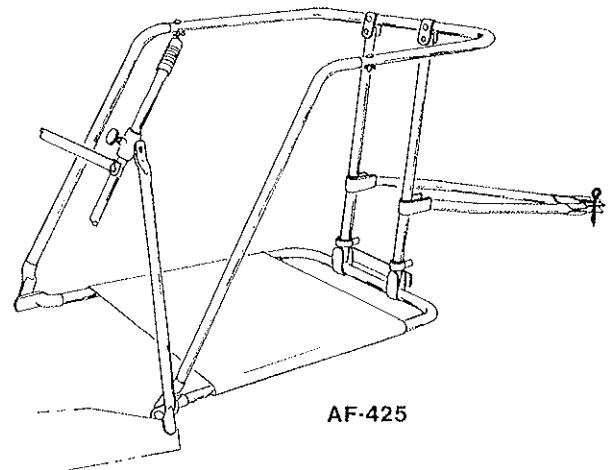

Other Scavenger Accessories available are: Snap-on Hose Kit, MA-482-C; Converta-Blow Deflector, MA-492-A.

OPERATING INSTRUCTIONS

IMPORTANT – Read the engine instruction manual and add the proper gasoline and oil to the engine.

- To start the engine, place the throttle control lever on the engine in the start position.
- To stop the engine, move the throttle control lever to stop position. The engine has a built-in stop switch.
- For maximum vacuum, operate machine at full throttle.
- To adjust the nozzle height above the ground, raise or lower the side wheels to the required position. For best results on a hard paved surface the nozzle should be about 1/2" above surface. For picking up lawn debris, the nozzle should be about 1 1/4" above the top of the grass.

MAINTENANCE INSTRUCTIONS

1. Be sure to keep the oil at the proper level in the engine. Check the oil level each time you fill the fuel tank.
2. Clean the engine air cleaner every 10 hours of operation. (Do so more often under dusty conditions.) If it is punctured, torn, or uncleanable, it should be replaced.
3. Keep the dust bag clean and dry. Clean the bag thoroughly after each use. A dirty bag will reduce the efficiency of the machine.
4. To drain the crankcase oil from the engine, we have provided a siphon pump. To use it, run the engine for a short time to warm the oil

and make it flow more easily. Then remove the cap from the filler hole in the engine and insert the plastic tube into the hole. Hold the pump below the bottom of the crankcase and squeeze it several times until oil appears in the tube above the pump, then disconnect the pump from the tube and allow the oil to siphon into a container for disposal. **DISPOSE OF PROPERLY.**

5. Once a year, remove the wheels and add fresh grease in the teeth of the gears. Also, before each use oil the wheel axles through the oil holes in the wheel hubs.

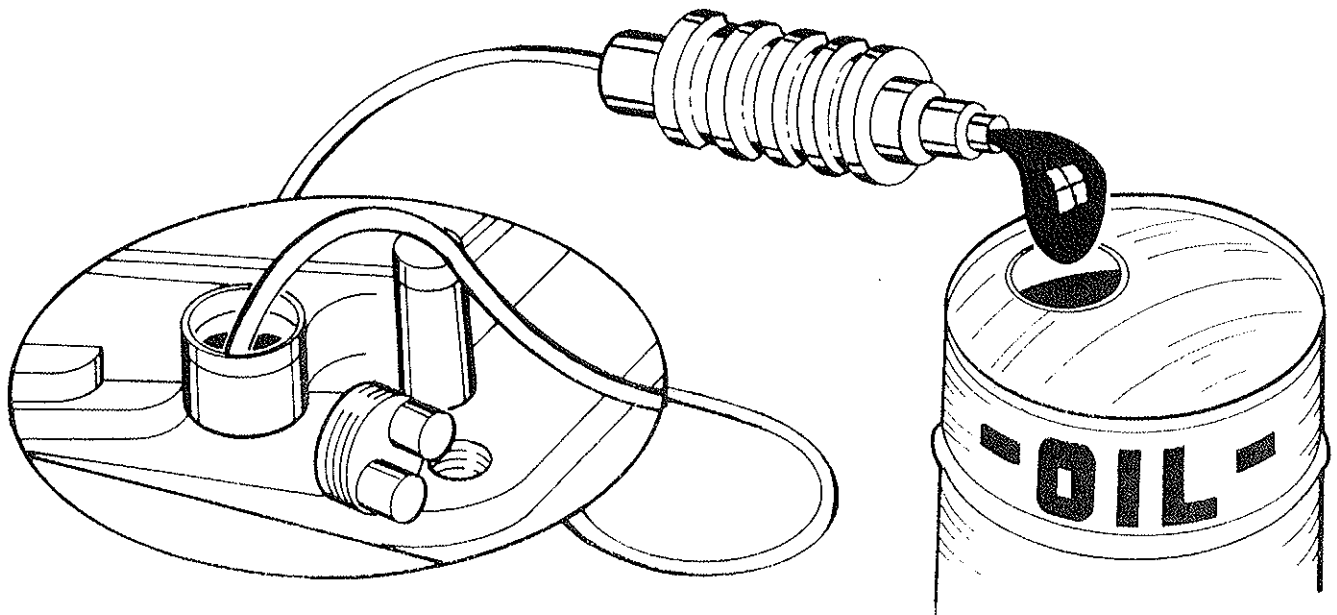

AF-220

HANDLE AND BAG ASSEMBLY

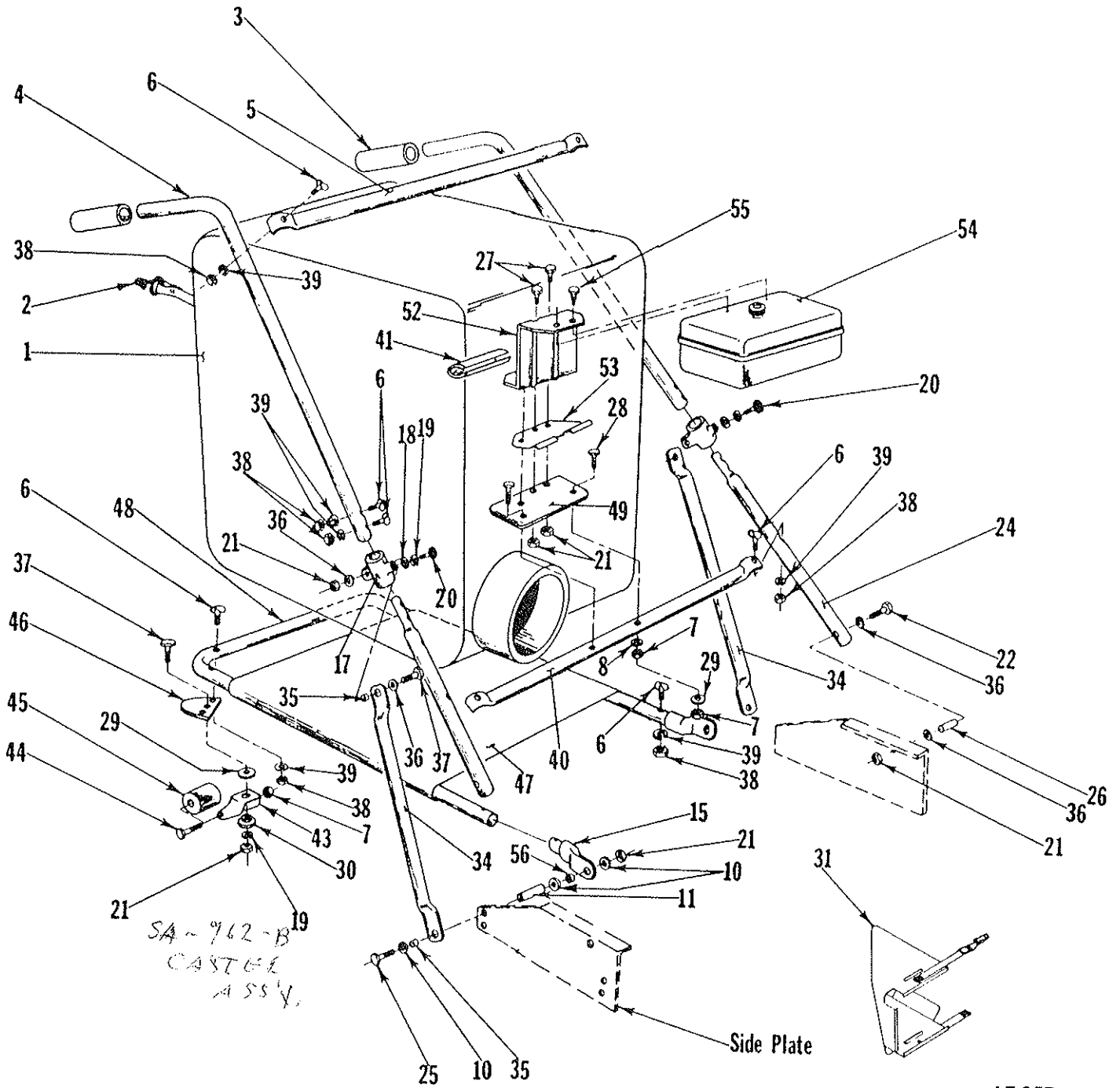

HANDLE AND BAG ASSEMBLY

PARTS LIST

Ref. No.	Part No.	Qty. Per Unit	Description
1	MA-426-1	1	Dust Bag Assy.
2	63-304-A	2	Bag Hook
3	60-233-A 80-232-A	2	Handle Grip, Blue
4	80-321-C	2	Upper Handle
5	81-157-B	1	Cross Bar Upper
6	69-416-24	14	Bolt, Contour Hd. 1/4-20x1½
7	365-416	4	Nut, Hex. Lock 1/4-20
8	945-416	2	Flatwasher 1/4
10	76-36-A	6	Special Washer
11	82-31-A	2	Spacer
15	81-116-A	2	Tubing End Cap
17	80-246-B	2	Pivot Bracket
18	936-516	2	Lockwasher, Int. Tooth 5/16
19	935-516	4	Lockwasher, Spring 5/16
20	80-228-A	2	Knurled Torque Knob
21	365-516	11	Nut, Hex. Lock 5/16-18
22	65-516-28	2	Bolt, Hex. Hd. 5/16-18x1¾
24	81-60-B	2	Middle Handle
25	65-516-36	2	Bolt, Hex. Hd. 5/16-18x2¼
26	80-238-A	2	Handle Inserts
27	65-516-12	3	Bolt, Hex. Hd. 5/16-18x3/4
28	65-416-32	2	Bolt, Hex. Hd. 1/4-20x2
29	50-230-A	4	Special Washer
30	78-130-A	2	Caster Bearing
31	82-194-C	1	Deflector Assy.
34	80-187-C	2	Truss Brace
35	54-227-A	4	Spacer
36	945-516	8	Flatwasher 5/16
37	65-516-16	4	Bolt, Hex. Hd. 5/16-18x1
38	335-416	14	Nut, Hex. Plain 1/4-20
39	935-416	14	Lockwasher 1/4
40	81-156-B	1	Cross Bar Lower
41	81-200-A	1	Bag Protector
43	76-136-B	2	Caster Fork
44	76-202-A	2	Axle
45	81-79-A	2	Roller
46	82-02-B	2	Caster Plate
47	81-117-C	1	Bag Platform
48	81-96-C	1	Frame, Bag Platform
49	81-145-B	1	Tank Bracket
*52	22-553-153	1	Lower Bracket
*53	22-533-154	1	Tank Support
*54	1-A-116-251-26	1	Gas Tank, 4 Qt.
*55	42-481-60	2	Self Tapping Screw
56	81-120-A	2	Spacer

*(Tecumseh Part No.)

CHASSIS ASSEMBLY

PARTS LIST

Ref. No.	Part No.	Qty. Per Unit	Description
1	365-516	14	Nut, Hex. Lock 5/16-18
**2	81-128-D-1	1	Engine, Tecumseh 5 H.P.
3	6165-A	1	Key, Engine
4	365-616	5	Nut, Hex. Lock 3/8-16
5	82-04-C	1	Upper Housing
6	73-414-A	1	Spacer
7	65-516-24	3	Bolt, Hex. Hd. 5/16-18x1½
9	SA-1014-B	1	Impeller Assembly
11	363-816	2	Nut, Hex. Lock 1/2-20
12	58-05-A	4	Flatwasher 1/2
13	58-06-A	2	Sleeve
14	SA-1036-C	2	Wheel & Tire Assy.
15	76-325-A	2	Spacer
16	60-816-52	2	Bolt, Hex. Hd. 1/2-20x3¼
17	81-115-A	1	Side Plate, L.H.
18	65-616-44	2	Bolt, Hex. Hd. 3/8-16x2¾
19	945-616	4	Flatwasher 3/8
20	935-516	2	Lockwasher, Spring 5/16
21	70-85-A	2	Spacer Bushing
22	70-69-A	2	Front Wheel
23	79-139-A	2	Blower Spacer
24	936-616	2	Lockwasher, Int. Tooth 3/8
25	81-129-B-5	4	Bolt, Hex. Hd. 3/8-16x1
26	81-129-B-4	2	Vinyl Spring Tip, Red
27	81-129-B-3	2	Spring Lever Assy.
	81-129-B-1	2	Slide Plate
	81-129-B-2	2	Back Plate
28	82-09-D 84-47-D	1	Housing Assembly
29	82-11-C	1	Support, Side Plate
32	81-114-A	1	Side Plate RH
*33	60-616-28	1	Bolt, Hex. Hd. 3/8-24x1¾
34	935-616	1	Lockwasher, Spring 3/8
35	64-178-A-1	1	Rub-R-Shim 1"
37	64-178-A-9.5	1	Rub-R-Shim 9½"
38	64-178-A-6	2	Rub-R-Shim 6"
39	81-123-A	1	Cross Brace
40	76-270-A	2	Insert
41	65-516-12	11	Bolt, Hex. Hd. 5/16-18x3/4
44	76-269-A	2	Lag Bolt 5/16x1
45	65-616-12	1	Bolt, Hex. Hd. 3/8-16x3/4

*Torque to 29-33 Lt. lbs.

**Tecumseh Model No. LAV-501A
Spec. 62076E

Order all parts from your nearest PARKER PARTS DISTRIBUTORS. If unable to locate the part from your Parts Distributor, forward your order to PARKER SWEEPER COMPANY for handling.

Hart-Greer, Inc. 900 N. 24th St. BIRMINGHAM, AL 35203	Bruce Engine, Inc. 1791 N.W. 86th St. DES MOINES, IA 50322	The Messinger Company, Inc. 374 Avery St. ROCHESTER, NY 14606	Fidelity Sales Corp. 447 E. Market St. KINGSPORT, TN 37662
Lawn & Garden Supply Co. 2222 N. 27th Ave. PHOENIX, AZ 85017	Morton B. Collins 300 Birnie Ave. SPRINGFIELD, MA 01106	Smith Hardware Co. 515 No. George St. GOLDSBORO, NC 27530	Fidelity Sales Corp. 6044 Lee Highway CHATTANOOGA, TN 37421
H. V. Carter Company 1700 E. 14th St. OAKLAND, CA 94606	Frost Company 483 Wildwood St. WOBURN, MA 01801	Hayward Distributing Co. 460 Neilston St. COLUMBUS, OH 43215	Goldthwaite's of Dallas, Inc. 2700 Forest Ln., Box 34660 DALLAS, TX 75234
Tarzana Mower & Engine Parts, Inc. 6075 Reseda Blvd. RESEDA, CA 91335	Frederick Trading Co. 7901 Trading Lane-Box 400 FREDERICK, MD 21701	Schroeder Sales & Service, Inc. 1144 Harrison Ave. HARRISON, OH 45030	Goldthwaite's of Ft. Worth 1401 Foch St. FT. WORTH, TX 76107
Colorado Outdoor Equip., Inc. 527 W. Evans DENVER, CO 80223	Adams Equipment, Inc. 8001 Newell St. SILVER SPRINGS, MD 20910	Hershman's, Inc. 12477 Benner Rd. RITTMAN, OH 44270	Goldthwaite's of Houston, Inc. 220 Farris HOUSTON, TX 77025
Zaun Equipment, Inc. 1741 Hamilton St. JACKSONVILLE, FL 32210	Ideal Mower Sales, Inc. 811 Woodward Heights FERNDALE, MI 48220	PARKER SWEEPER COMPANY P. O. Box 1728 SPRINGFIELD, OH 45501 Phone: 513-323-4901	Goldthwaite's of Texas, Inc. 10751 Sentinel SAN ANTONIO, TX 78217
Florida Turf & Garden 7275 N.W. 64th St. MIAMI, FL 33166	Lorenz Service Company 2500 S. Pennsylvania Ave. LANSING, MI 48910	M. P. E. Sales, Inc. 25850 Chardon Rd. CLEVELAND, OH 44143	Boyd Martin Company 1260 N. W. Temple SALT LAKE CITY, UT 84116
Zaun Equipment, Inc. 1140 S. Rio Grande Ave. ORLANDO, FL 32805	Power Equipment Distributors, Inc. 340 N. Hubbard MT. CLEMENS, MI 48043	Tri-County Sales & Service 15 North West Ave. YOUNGSTOWN, OH 44502	Wetzel Seed Co. 941 N. Liberly HARRISONBURG, VA 22801
De Bra Turf & Industrial Equip. Co. 5921 N. Oak St. HOLLYWOOD, FL 33021	R. L. Gould Company 3711 N. Lexington Ave. ST. PAUL, MN 55112	Wait Sales Company 406-10 S. Peoria, Box 1015 TULSA, OK 74120	The Bentley Company 4126 Airport Way, S. SEATTLE, WA 98108
De Bra Turf & Industrial Equip. Co. 6025 U.S. Hwy. 301 TAMPA, FL 33610	Hance Distributors 420 Excelsior Ave., W. HOPKINS, MN 55343	Baltz & Son Co. 9817 E. Burnside PORTLAND, OR 97216	Northwest Mower, Inc. 926 N. 165th St. SEATTLE, WA 98133
Snapper Equipment Distributor 204 E. Buffalo Ave. TAMPA, FL 33603	Gunthers Service & Supply 7320 Wornall Rd. KANSAS CITY, MO 64114	Monroe Machinery & Supplies, Inc. 1421 S. E. Gidson St. PORTLAND, OR 97242	Interstate Radiator & Lawn Mower Co. 1611 4th Ave. CHARLESTON, WV 25312
Lawn & Turf, Inc. 2570 Old Covington Hwy. CONYERS, GA 30207	Henzler, Inc. 2015 Lemay Ferry Rd. ST. LOUIS, MO 63125	Lawn & Golf Supply Co. 647 Nutt Rd. PHOENIXVILLE, PA 19460	Reinders Brothers, Inc. 13400 Watertown Plank Rd. ELM GROVE, WI 53122
Tyner Distributing, Inc. 5437 Kendall St. BOISE, ID 83706	Port Huron Machinery & Supply 801 Q St. LINCOLN, NE 68508	Gardenville Supply Co., Inc. Route 611 PIPERSVILLE, PA 18947	R. L. Gould 344 Berger St. GREEN BAY, WI 54302
Plante's Lawn Equipment, Inc. 4 Grant St. NORTH AURORA, IL 60542	George Smith & Sons, Inc. 322 Broadway BETHPAGE, L.I., NY 11714	Bluemont Co. 11125 Frankstown Rd. PITTSBURGH, PA 15235	Van's Supply & Equip. Co., Inc. 2640 So. Ashland Ave. GREEN BAY, WI 54303
Davis Turf Products, Inc. 435 So. Wheeling Rd. WHEELING, IL 60090	Grasslands Equip. & Irrigation 892 Troy Schenectady Rd. LATHAM, NY 12110	Niemeyer Corp. 1135 Phoenixville Pike, Box 1477 WEST CHESTER, PA 19360	Fallis Turf Equip., Ltd. 11951 Forge Place RICHMOND, B.C., CANADA V7A 4V9
T. E. Booher & Sons 1009 W. State St. ALBANY, IN 47320	Henry W. O'Neill & Associates, Inc. 410 N. Goodman St. ROCHESTER, NY 14609	Fidelity Sales Corp. 6331 Baum Dr. KNOXVILLE, TN 37919	Duke Lawn Equipment 1184 Plains Rd., East BURLINGTON, ONTARIO, CANADA L7S 1W6